



Laboratory Testing of Portable Air Cleaner Products for Energy Efficiency and Clean Air Performance at Various Fan Settings

March 17, 2026

**Kevin Keene, Alfiya Orman, Jason Tuenge,
Meghan McNulty, Gabe Arnold**



PNNL-38694

PNNL is operated by Battelle for the U.S. Department of Energy

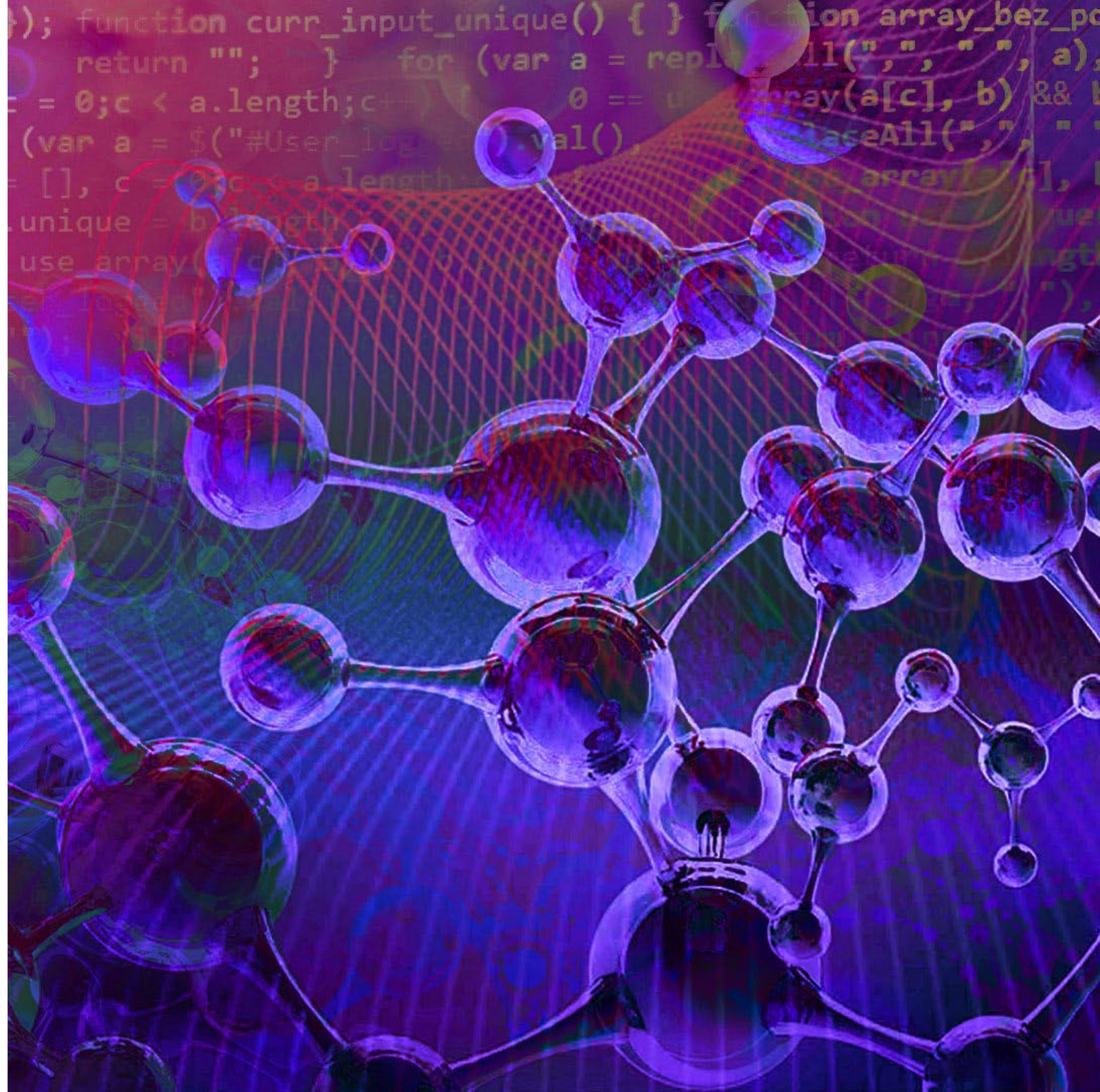

Room/Portable Air Cleaner (PAC) Laboratory Testing



PAC classroom installation at Dekalb School District, Atlanta, GA

- **Opportunity:** PNNL research finds using PACs to clean air in commercial buildings can reduce energy consumption by 70%+ compared to central HVAC ventilation solutions. PACs are also more retrofittable and affordable for existing buildings.
- **Challenges:** PACs can be noisy, under-sized, operated at less effective low settings, or unplugged. There is wide variability in performance across products, and a lack of stakeholder guidance and education.
- **PNNL Scope:** Test variety of PAC products in lab to better understand and optimize performance (energy, acoustics, clean air performance, size, pathogen/particle reduction).
- **Goal:** Help industry develop better PAC products; help end-users with better operation and more efficient, effective, and affordable solutions to providing clean air.

PAC Limitations Literature Review

- **Noise:** Noise is the most frequently cited complaint from PAC operation at high fan speeds in classrooms [1][2][3] and hospitals [4] although not all products elicited complaints in two of the studies
- **Sizing:** One study [1] found that, if all devices operated on the highest setting, only 14% of the classrooms would meet AHAM-recommended 5 ACH, suggesting that the devices are undersized or require a higher quantity.
- **Placement:** One study [4] found that PACs were often placed in nonideal locations (corner of room, under a table, etc.).
- **Utilization:** One study [5] found PACs were left on an average of 81% of school hours and the highest fan speed was used 69% of that time.
 - There could be bias that the participants knew they were being studied and left it on more than they would otherwise.

Product Review

A review of 34 commercially available PAC products from 18 different brands was conducted, using ENERGY STAR certified products as a starting point and then adding products featured on the Wirecutter and Consumer Reports websites. A summary of the findings:

- **Cost:** The costs vary from about \$126 to \$1,400, with an average of \$398. The average filter cost replacement is \$75, ranging from \$23 to \$200.
- **Performance:** The CADR values vary between 48 cfm and 580 cfm, with an average value of 295 cfm. There is a wide range in efficiency (CADR/W) with most products ranging between 1.9 and 10.0, and 28 of the products qualify for ENERGY STAR.
- **Noise:** The average rated noise level for the products is 29 dB at the lowest fan speed and 54 dB at the highest fan speed.
- **Settings:** Most products have at least three fan speeds; only three products offer a single speed option. Most feature an "auto" or "eco" mode and a "night" or "sleep" mode.
- **Customer Reviews:** The most common customer complaints on retail websites are a high filter price and chemical odors from the devices. Some of the products have complaints for excessive noise, excessively bright display lights, and frustrating or unintuitive controls.

Product Review Correlations

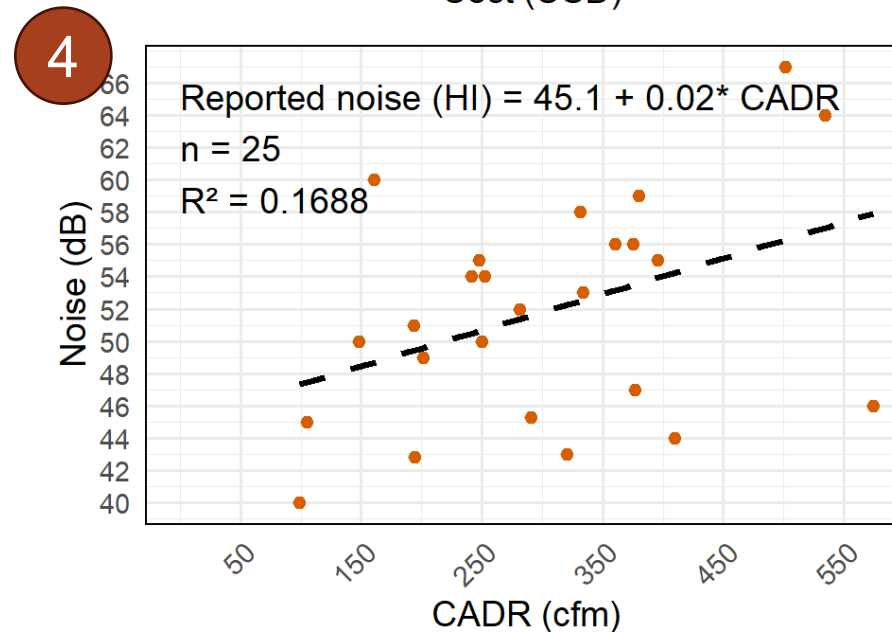
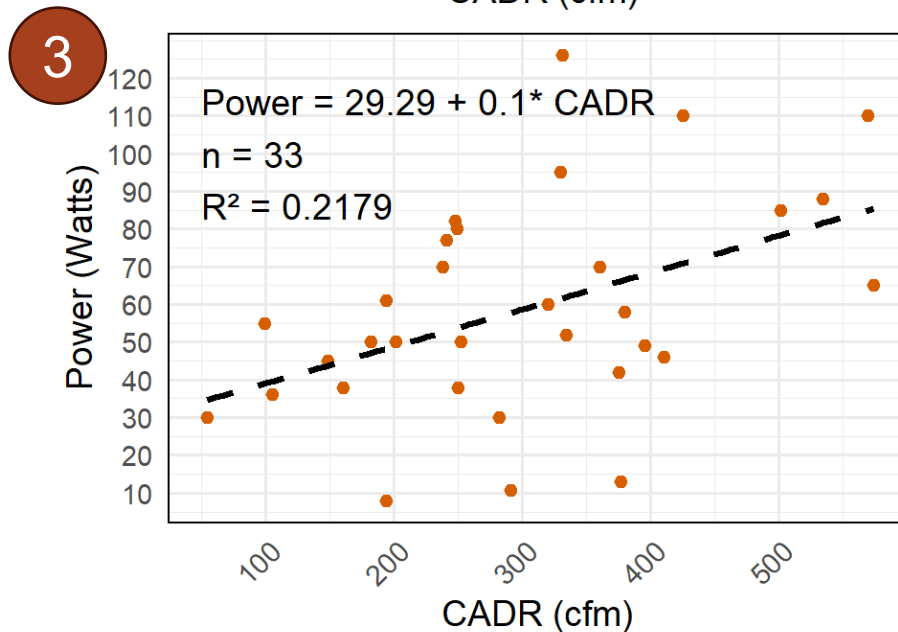
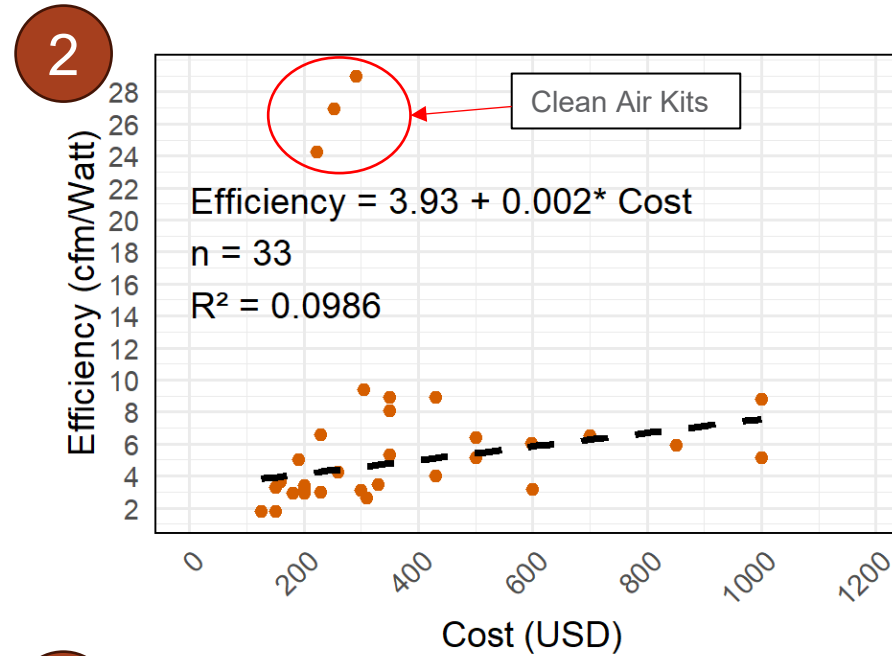
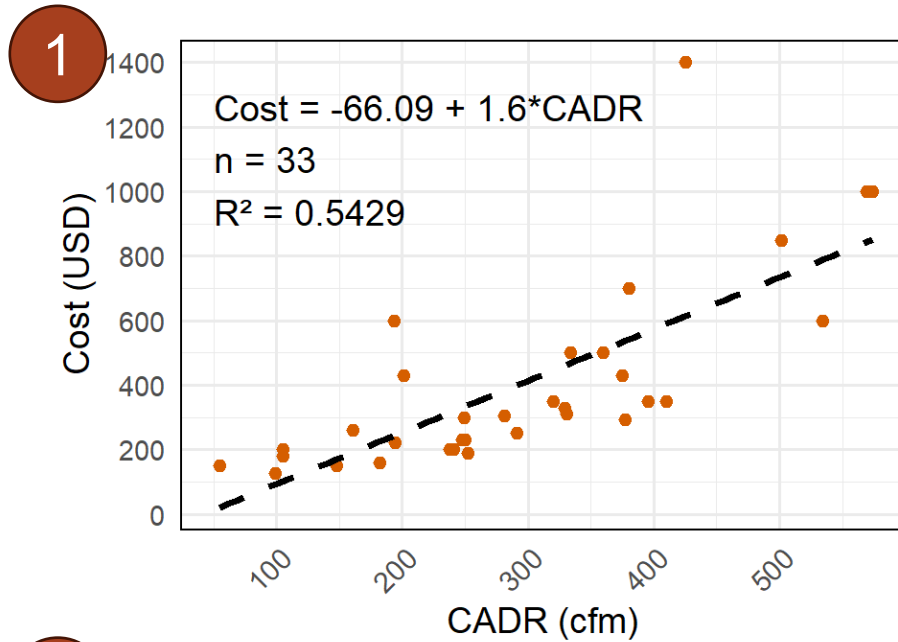

None of the correlations have great R^2 values due to confounding factors; however, these four relationships show general trends across products:

(1) Higher CADR (on max setting) is correlated to higher cost

(2) Higher cost is correlated to higher efficiency (on max setting)

- Clean air kits are outliers, rated for very high efficiency relative to other products

(3) Higher CADR (on max setting) is correlated to higher power (on max setting)

(4) Higher CADR (on max setting) is correlated to higher noise (on max setting)

CADR is calculated as the average of smoke and dust CADR on highest setting

Laboratory Testing Objectives

Generate product data to better understand the variation in performance among PACs with respect to energy use and clean air delivery

- Research questions:
 1. What is the relationship between clean air delivery rate (CADR) and energy across a range of products? What is the general decrement in CADR as a result of operating at lower fan speeds? What is the relationship between efficiency (CADR/W) and fan power?
 2. How might the multiple units at lower power compare to fewer, larger units at full power in terms of energy efficiency and total cost?
 3. How do the measured CADR, power, and efficiency compare to the manufacturer specs?
 4. Are there product attributes that can be identified that might contribute to better CADR/W performance?

Laboratory Testing

7 products were selected from a review of 34 products to undergo laboratory performance testing in accordance with AHAM AC-1 procedure.

- **Fixed Variables:**

- Size range (all rated 400-600 cfm, larger end)
- 3+ fan speeds
- Popular / large consumer base

- **Range Variables:**

- Cost
- Efficiency
- Noise

- At laboratory, only three fan settings tested (lowest, medium, and highest) even if more settings were available to reduce testing cost.

- Measured values: smoke CADR (s-CADR), dust CADR (d-CADR), pollen CADR (p-CADR) and power

Summary of Device Features

Device ID	Number of Fan Speeds	Modes	Filters	Filter Replacement	Ion Generator	Sensor
2025-PAC-1	6	Auto, Night	Pre-filter, Carbon/VOC filter, UltraHEPA	1 year (HEPA), 6 months (Carbon/VOC)	Yes	Only with more expensive model
2025-PAC-2	4	Auto, Night	Pre-filter, Particle filter, Carbon filter	1 year	No	PM _{2.5} , PM ₁₀ , and PM _{1.0} sensor
2025-PAC-3	4	Auto, Sleep	Pre-filter, Carbon filter, H13 True HEPA	6-12 months	No	PM _{2.5} sensor
2025-PAC-4	3	Eco, Silent, Turbo, Auto	Pre-filter, Carbon filter, True HEPA	1 year	No	PM _{2.5} , PM ₁₀ , and PM _{1.0} sensor
2025-PAC-5	4	Auto, Sleep	Pre-filter, Carbon filter, H13 True HEPA	1 year	No	PM _{2.5} and TVOC sensor
2025-PAC-6	8	Smart (Quiet, Balanced, or Max)	Pre-filter, HyperHEPA	1 year	No	PM _{2.5} , CO ₂ , Temp, and RH
2025-PAC-7	4	Auto, Sleep	Pre-filter, Carbon filter, H13 True HEPA	9-12 months	Yes	PM _{2.5} sensor

Summary of Manufacturer Device Specs

Device ID	Upfront Cost	Filter Rep. Cost	5-year Maint. Cost	5-year Utility Cost	Life Cycle Cost	CADR	Noise on Low (dB)	Noise on High (dB)	Efficiency (cfm/W)	Customer Reviews
2025-PAC-1	\$1,000	\$133	\$2,330	\$406	\$3,736	530	30	-	4.9	Unit is very quiet. Complaints about customer service.
2025-PAC-2	\$350	\$70	\$700	\$156	\$1,206	410	23	44	8.9	Filter replacement price too high. Complaints about the Wi-Fi model.
2025-PAC-3	\$598	\$60	\$1,788	\$307	\$2,693	506	35	64	5.9	Filter replacement price too high. Loud at settings 3 and 4.
2025-PAC-4	\$1,000	\$100	\$1,995	\$197	\$3,192	533	23	46	10.2	Customers overall happy.
2025-PAC-5	\$850	\$293	\$2,313	\$289	\$3,452	484	-	67	6.1	Cost of unit too high. Very big in size.
2025-PAC-6	\$1,400	\$67	\$2,400	\$304	\$4,104	433	-	-	4.9	Complaints of burning odor.
2025-PAC-7	\$350	\$60	\$950	\$166	\$1,466	408	26	55	8.1	Complaints about sensor not working. Complaints that it does not filter VOCs.

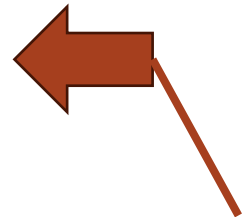

These two products stand out for high efficiency, low cost, and low noise

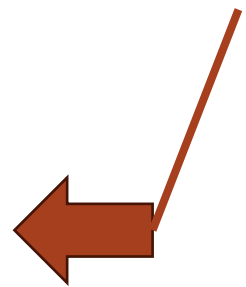

↑
Big range in upfront cost, \$350 - \$1,000

↑
Filter replacement is 58-67% of total life cycle cost

↑
Large ranges in noise as well, 44-67 dB on high setting

↑
Large range in rated efficiency, 4.9 – 10.2 cfm/W

Lab Results Performance VS Power

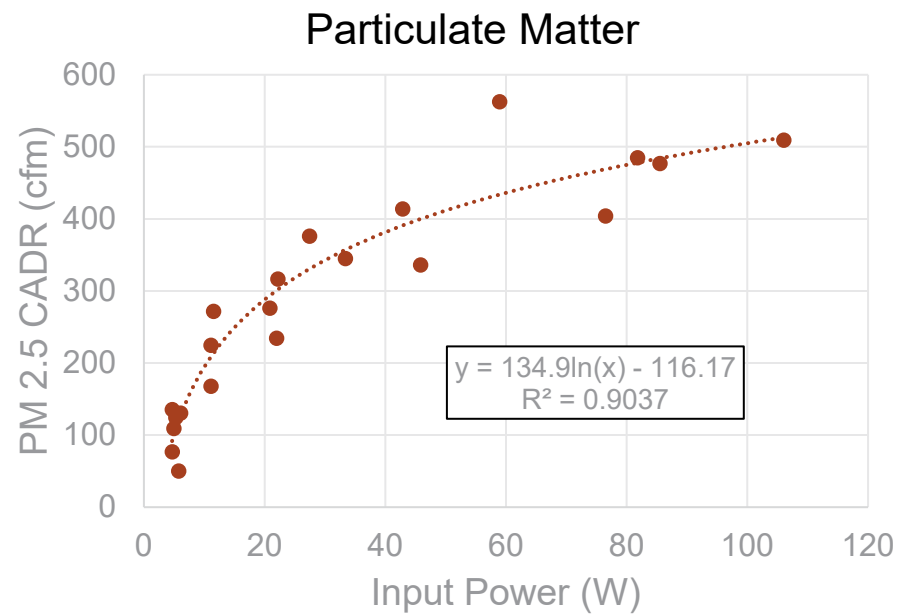
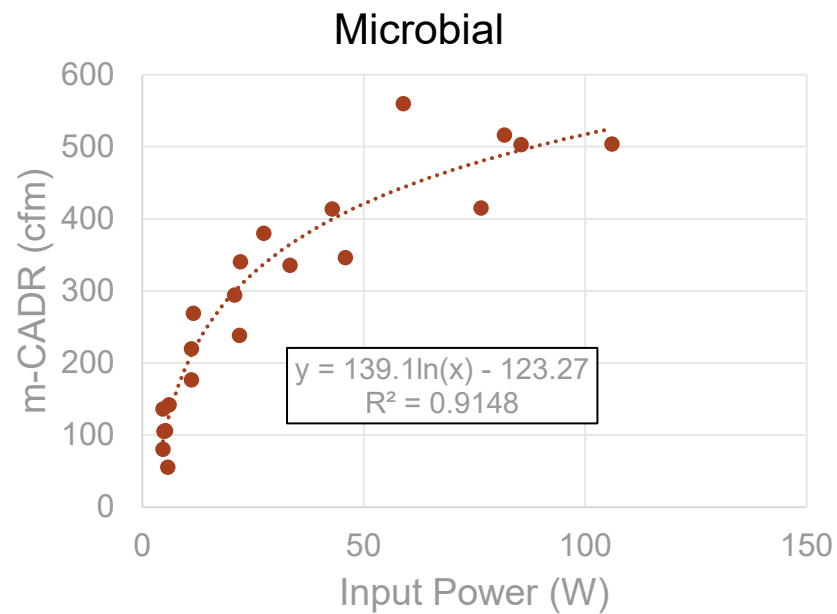
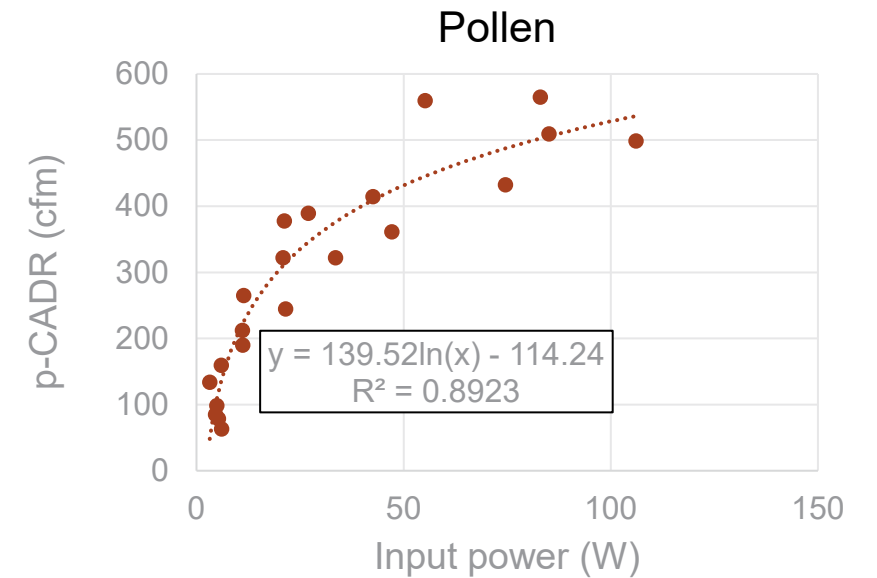
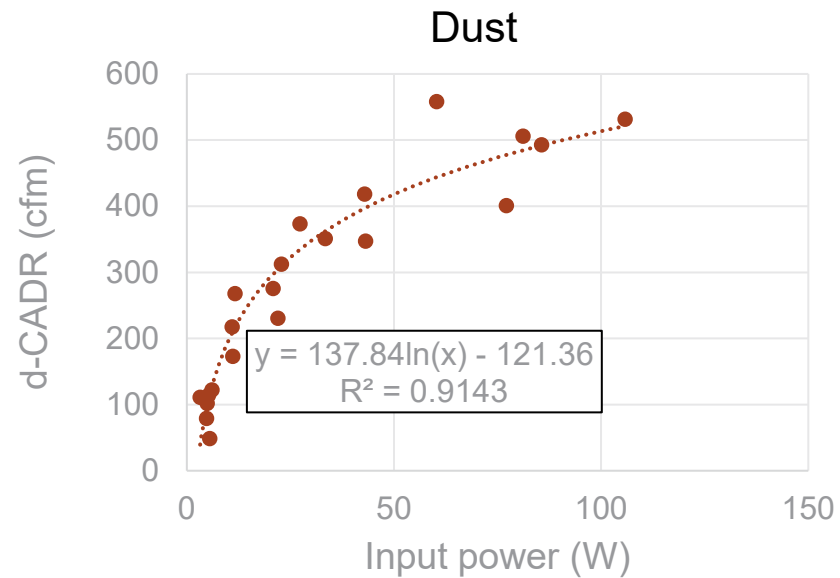
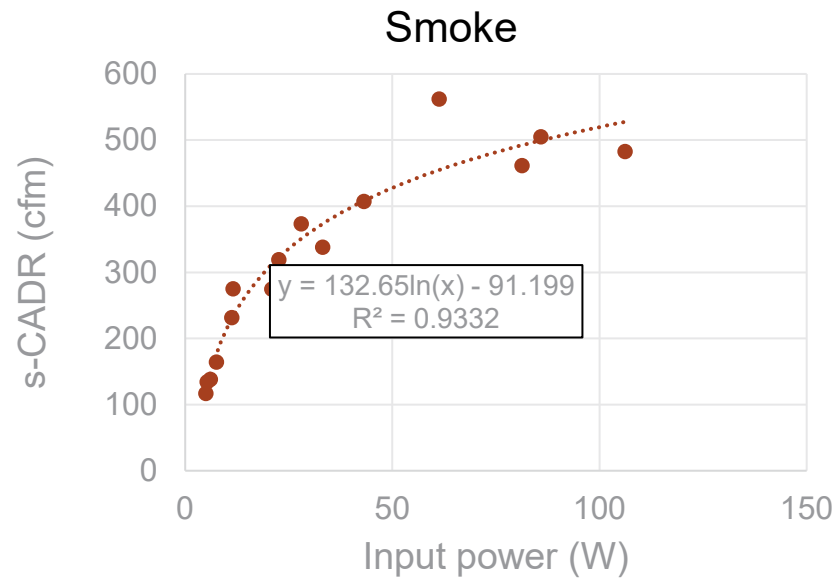

- 3 points for each device per plot, one for each fan setting
- The curves are similar form for all five plots
- CADR drops off steeply at very low power levels and plateaus at high power levels

Note: m-CADR and PM_{2.5} CADR are calculated values

Lab Results Performance VS Power

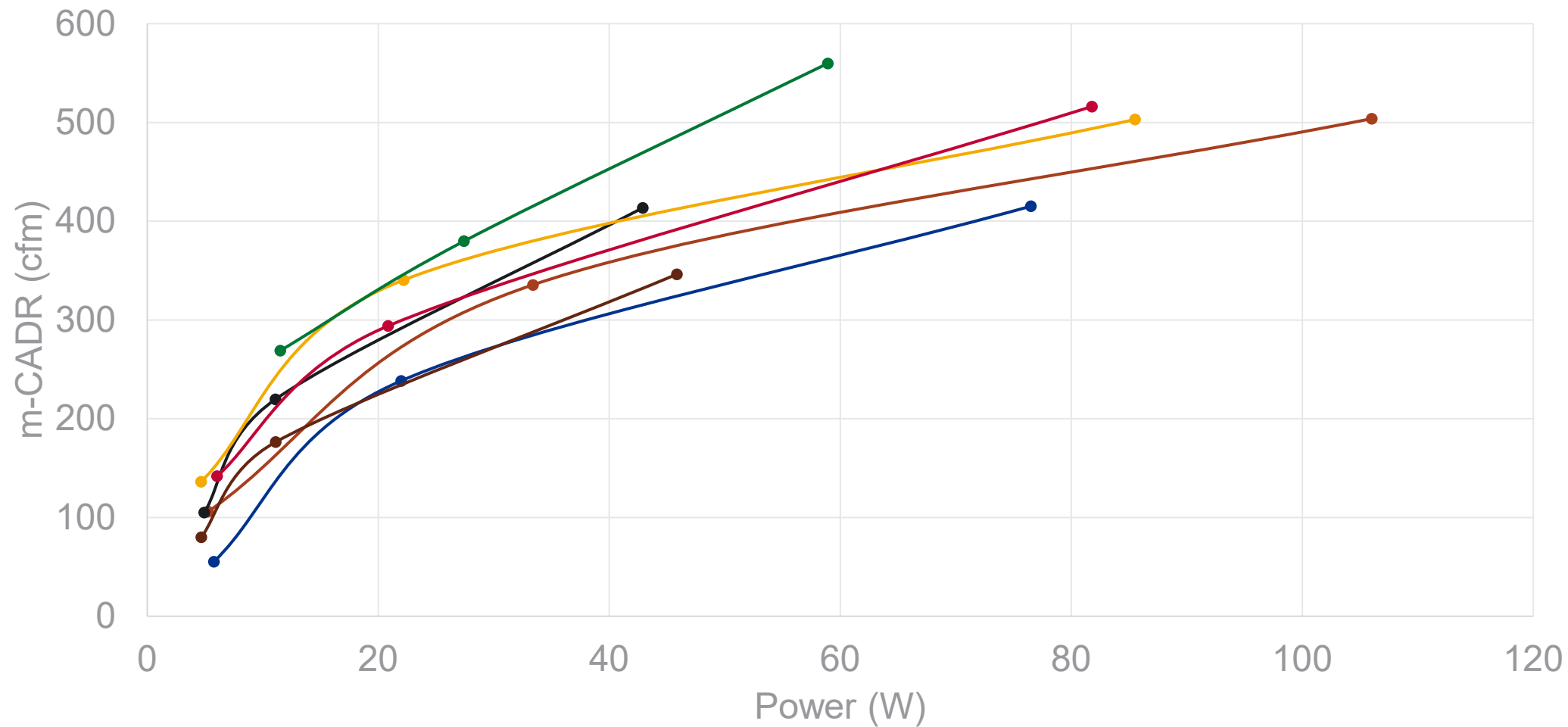

—●— 25-PAC-1 —●— 25-PAC-2 —●— 25-PAC-3 —●— 25-PAC-4
—●— 25-PAC-5 —●— 25-PAC-6 —●— 25-PAC-7

- For this chart, the data points are grouped by product
- Notably range across the curves, 100+ cfm at any given power level

Product Comparison

There tends to be one or two trade offs (red or orange) for each product, but **25-PAC-2** stands out:

- Least expensive
- Highest efficiency
- Second lowest rated sound

ID	Product Cost / CADR	Measured Efficiency (CADR/W)	Rated Sound (dB) / CADR
25-PAC-1	\$1.99	4.8	Not available
25-PAC-2	\$0.85	9.6	0.12
25-PAC-3	\$1.26	5.8	0.13
25-PAC-4	\$1.78	9.1	0.08
25-PAC-5	\$1.76	5.9	0.14
25-PAC-6	\$3.47	5.2	Not available
25-PAC-7	\$1.04	7.1	0.16

m-CADR used to calculate the values in this table.

Recommended Room Size by Fan Speed

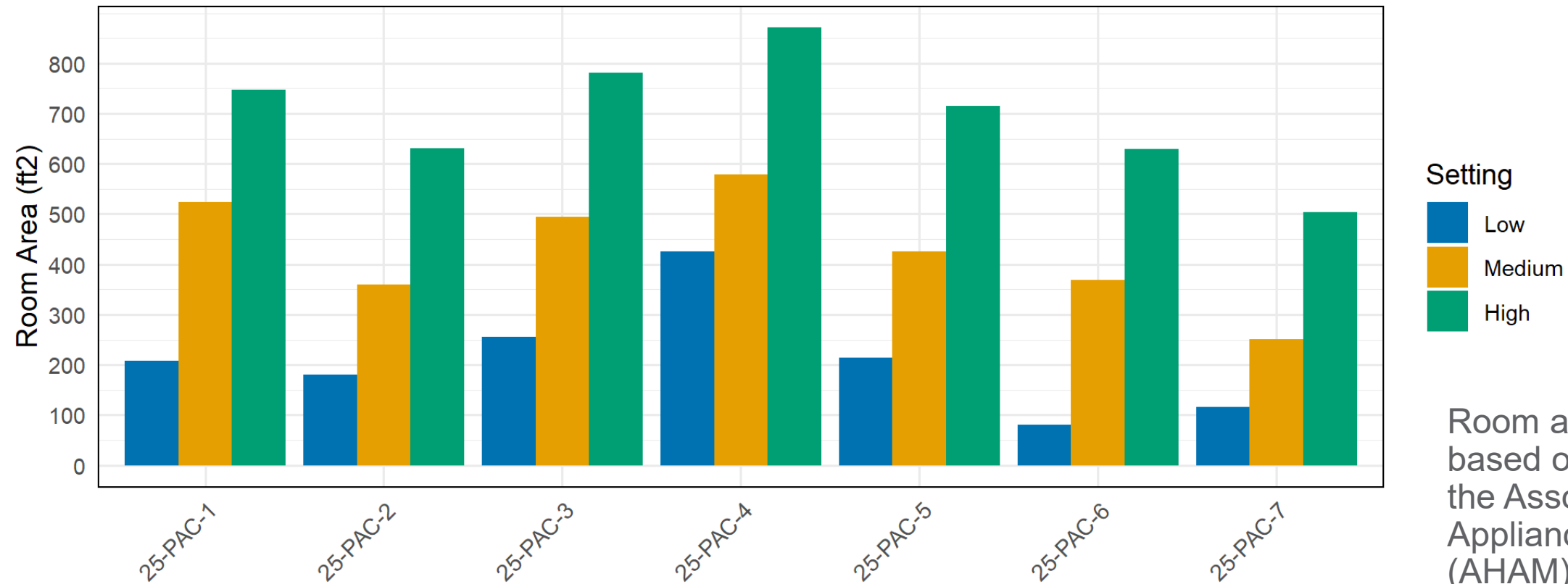

Room area is calculated based on CADR according to the Association of Home Appliance Manufacturers (AHAM) equation

- At the lowest fan setting, room coverage drops 70-85% for most products
 - Except for 25-PAC-4, only 50% drop from max setting
- At medium fan setting, room coverage drops 40-60%, which is a significant drop in clean air quantity and clean air range if the room is designed for devices to be running at the highest speed

Lab Results Efficiency VS Power

Efficiency vs Power by Fan Setting

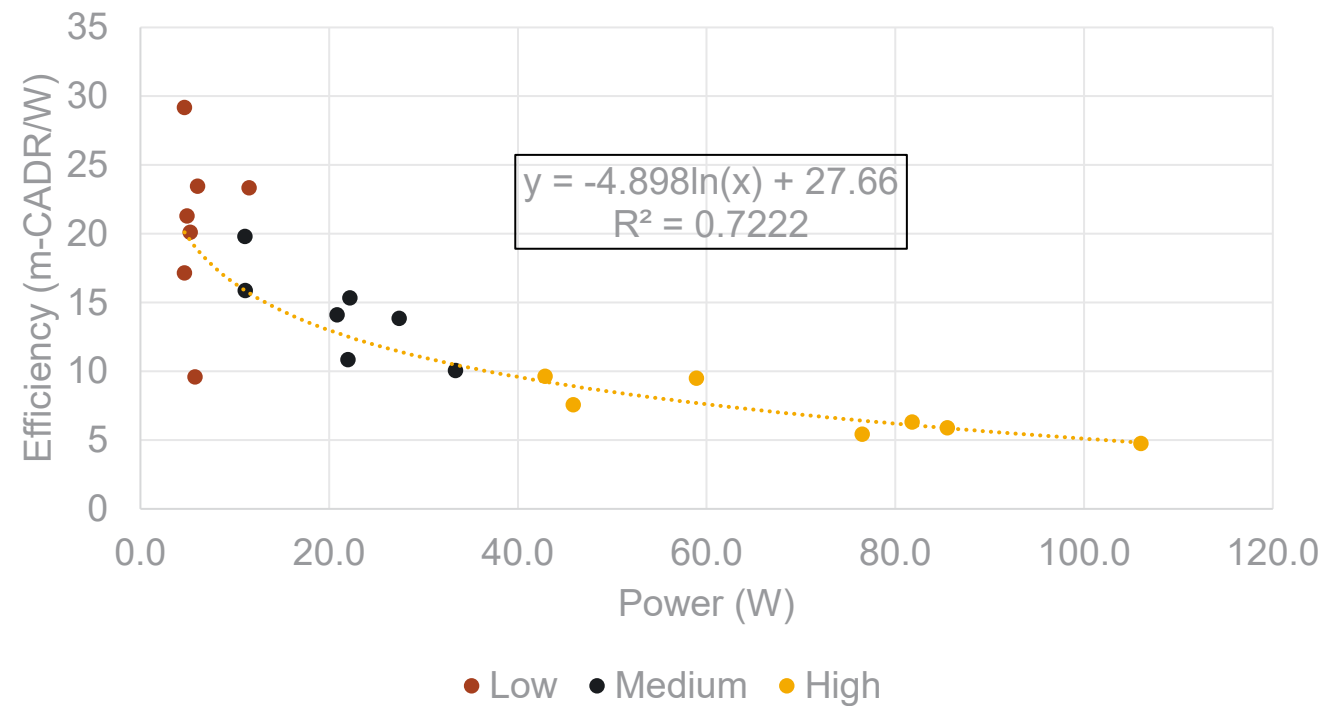

Efficiency vs Power by Product

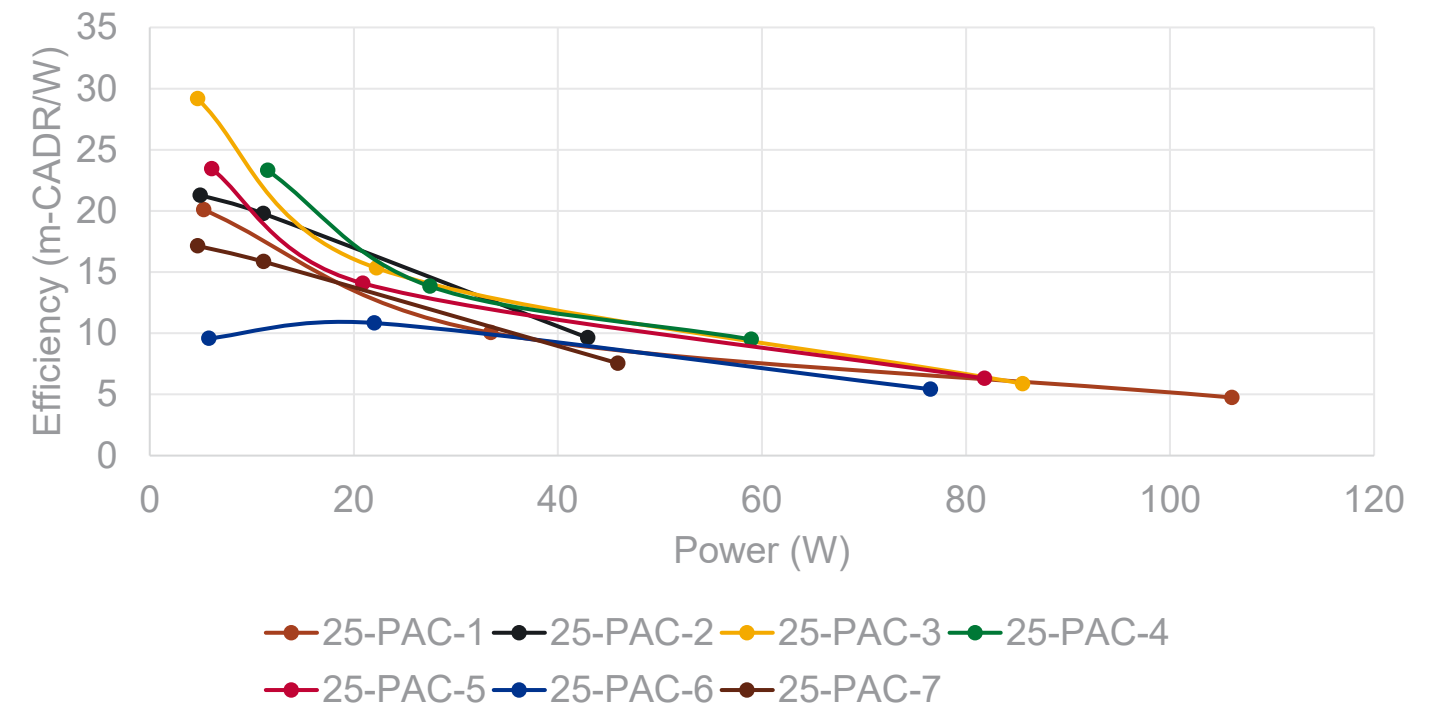

- PAC devices are more efficient at lower power settings
 - Trade off is significantly reduced CADR and room coverage

Using Multiple Devices on Lower Fan Setting

Research Question: Given these devices are more efficient at low fan speeds, is it more affordable to have more devices at lower fan speed (lower energy costs) or fewer devices at higher fan speed (lower purchase costs)?

Scenario: Classroom (40' x 25.75') to meet ASHRAE 241

- Required ECAi = 40 cfm/p * 36 occupants = 1,440 cfm
- Assume HVAC meeting ASHRAE 62.1 providing 18 cfm/p = 650 cfm, so 790 cfm needed from PACs
- Devices run 10 hr/day and 5 days/week

Notes:

- Assume more devices at lower setting do not add additional maintenance costs (same amount of pollutants just spread across more filters)
- Doesn't account for interactive effects between the devices to CADR
- Noise disturbance may be lower for multiple, lower fan devices (future research)

Using Multiple Devices on Lower Fan Setting

Lowest cost is yellow;
second lowest (if within \$1k)
is cyan.

Results:

- **Medium fan setting** is most affordable for majority (four of seven) of products
- **High fan setting** with fewer devices most affordable for two of seven and close second most affordable option for another four of seven

Device ID	Setting	# Devices	Total CFM	Total Power	Upfront Cost	5-year Maintenance Cost	5-year Utility Cost	Total Cost
25-PAC-1	Low	8	848	42.2	\$8,000	\$4,660	\$660	\$13,320
	Med	3	1007	100.2	\$3,000	\$4,660	\$1,560	\$9,220
	High	2	1008	212.1	\$2,000	\$4,660	\$3,310	\$9,970
25-PAC-2	Low	8	841	39.5	\$2,800	\$1,400	\$620	\$4,820
	Med	4	879	44.4	\$1,400	\$1,400	\$690	\$3,490
	High	2	827	85.8	\$700	\$1,400	\$1,340	\$3,440
25-PAC-3	Low	6	817	28.0	\$3,588	\$3,570	\$440	\$7,600
	Med	3	1022	66.6	\$1,794	\$3,570	\$1,040	\$6,410
	High	2	1006	171.1	\$1,196	\$3,570	\$2,670	\$7,440
25-PAC-4	Low	3	807	34.6	\$3,000	\$3,990	\$540	\$7,530
	Med	3	1139	82.3	\$3,000	\$3,990	\$1,280	\$8,270
	High	2	1120	117.9	\$2,000	\$3,990	\$1,840	\$7,830
25-PAC-5	Low	6	852	36.3	\$5,100	\$4,630	\$570	\$10,290
	Med	3	882	62.6	\$2,550	\$4,630	\$980	\$8,150
	High	2	1032	163.6	\$1,700	\$4,630	\$2,550	\$8,880
25-PAC-6	Low	15	831	86.7	\$21,000	\$4,880	\$1,350	\$27,150
	Med	4	954	88.0	\$5,600	\$4,880	\$1,370	\$11,770
	High	2	830	153.0	\$2,800	\$4,880	\$2,390	\$9,990
25-PAC-7	Low	10	802	46.8	\$3,500	\$2,850	\$730	\$7,080
	Med	5	883	55.7	\$1,750	\$2,850	\$870	\$5,470
	High	3	1039	137.6	\$1,050	\$2,850	\$2,150	\$6,050

Using Multiple, Smaller Devices

Research Question: Would using more, smaller devices at max speed (instead of running larger ones at partial speed) be a more affordable and efficient option compared to fewer, larger devices?

For this, we can leverage product review because we have CADR specs at max setting.

Results:

- The best option is fewer, larger devices, which turned out to be increasingly more efficient than more, smaller devices.
 - Previously, we found that large PACs operated at a low fan setting are more efficient than when operated at a high fan setting. This results suggests that it's not the absolute fan power that affects efficiency; rather the fan power relative to the overall size of the product.

Device Size	# Devices	Total CFM	Total Watts*	Efficiency (cfm/W)	Upfront Cost*	5-year Maintenance Cost	5-year Utility Cost	Total Cost
Large (395 cfm)	2	790	137.6	5.7	\$1,132	\$1,400	\$2,146	\$4,678
Medium (263 cfm)	3	790	166.9	4.7	\$1,066	\$1,800	\$2,603	\$5,469
Small (198 cfm)	4	790	196.2	4.0	\$1,000	\$2,000	\$3,060	\$6,060
Very Small (158 cfm)	5	790	225.5	3.5	\$934	\$2,000	\$3,517	\$6,451

*The values for cost and power are based on the regression models our product review, correlated to CADR—however, some variation could occur depending on the specific products chosen.

Measured vs Specifications (CADR)

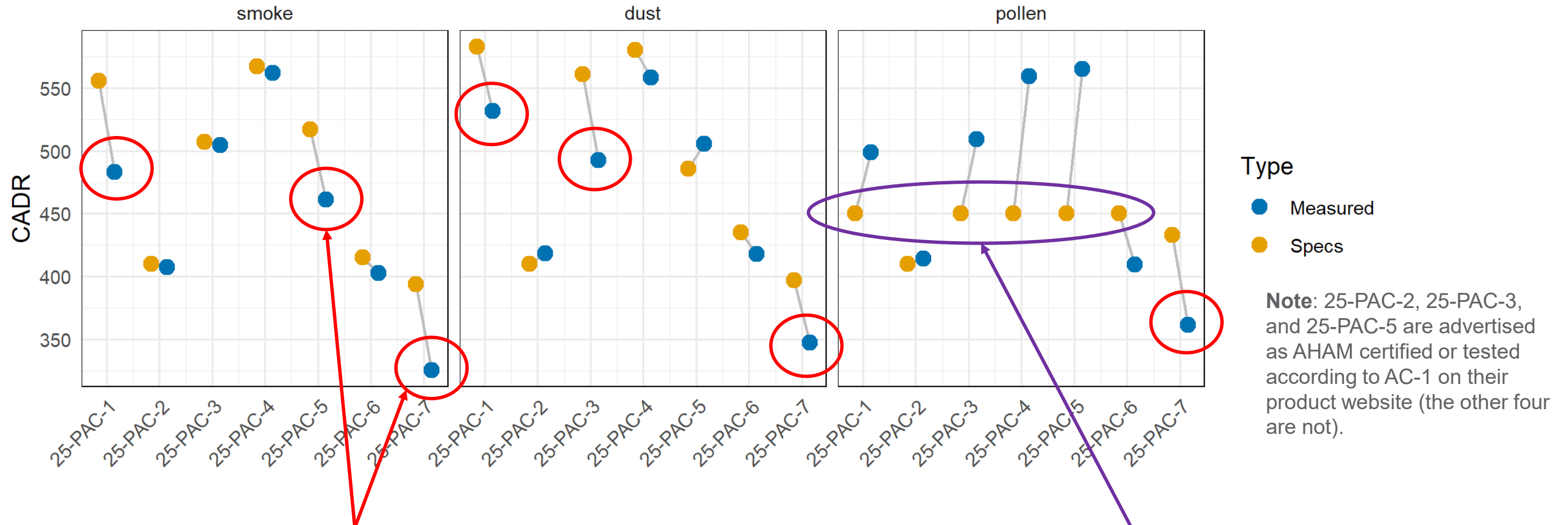

- The measured lab results for CADR (blue) generally align with the product specs (yellow), except for a few results where our lab results are ~10% - 17% worse than the product specs

- Note:** The testing procedure AHAM AC-1 is not rated for measuring pollen CADR above 450 cfm, which is why the manufacturer specs max out at that value. Our lab results still returned pollen CADR above 450 cfm, however. Best to ignore these results circled and just use smoke and dust for comparison.

Measured vs Specifications (Efficiency)

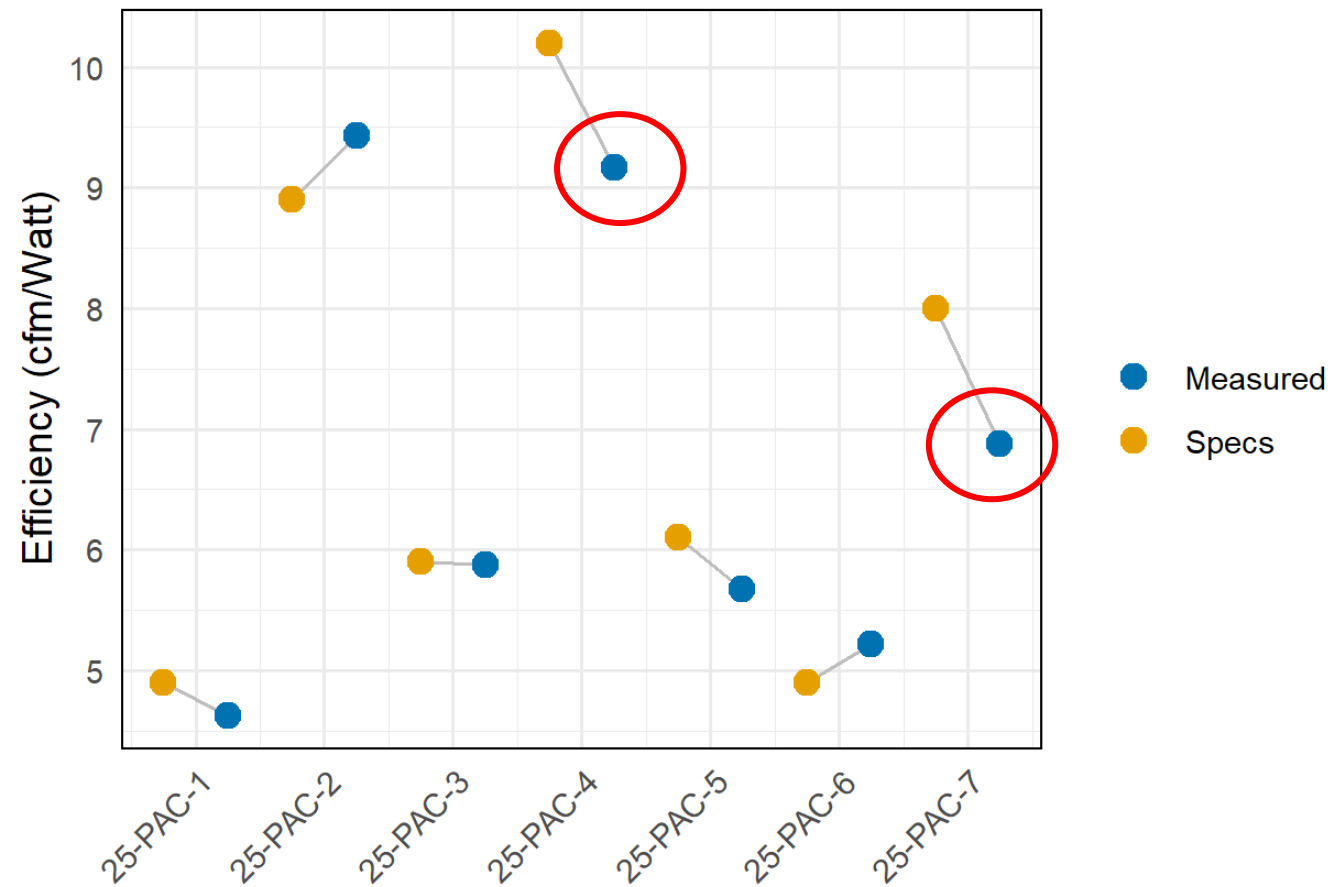

Note: 25-PAC-2, 25-PAC-3, and 25-PAC-5 are advertised as AHAM certified or tested according to AC-1 on their product website (the other four are not).

The measured lab results for CADR (blue) generally align with the product specs (yellow), except for two results (25-PAC-4 and 25-PAC-7) where our lab results are 10% and 7%, respectively, worse than the product specs

With Ionizer vs Without Ionizer

Two products had ionizer features, which are advertised to improve CADR. We tested with and without these features activated (except 25-PAC-7 was not tested at low fan setting with ionizer).

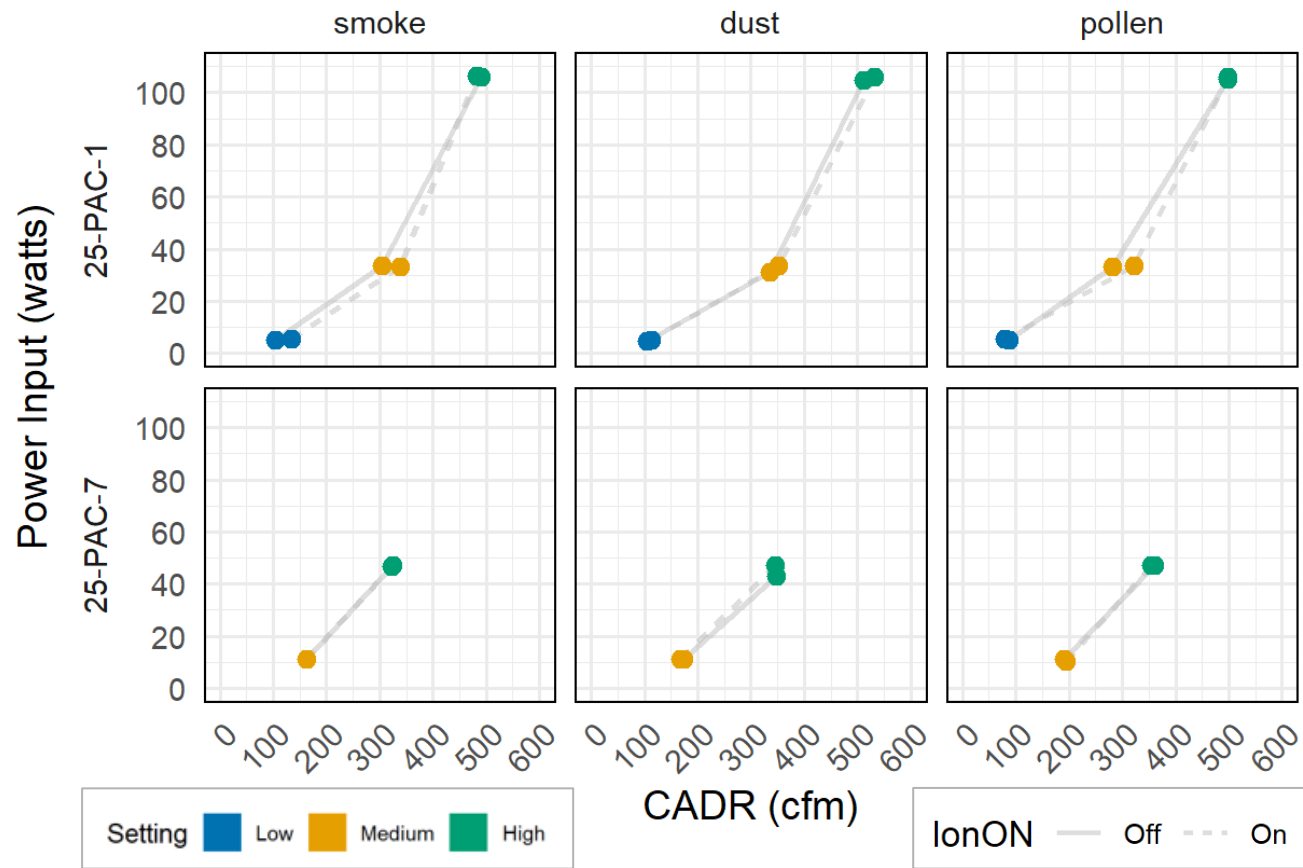

Power vs CADR: Impact varies based on pollutant and setting. Some points show a noticeable increase in CADR (x-axis) with a relatively small change in power (y-axis).

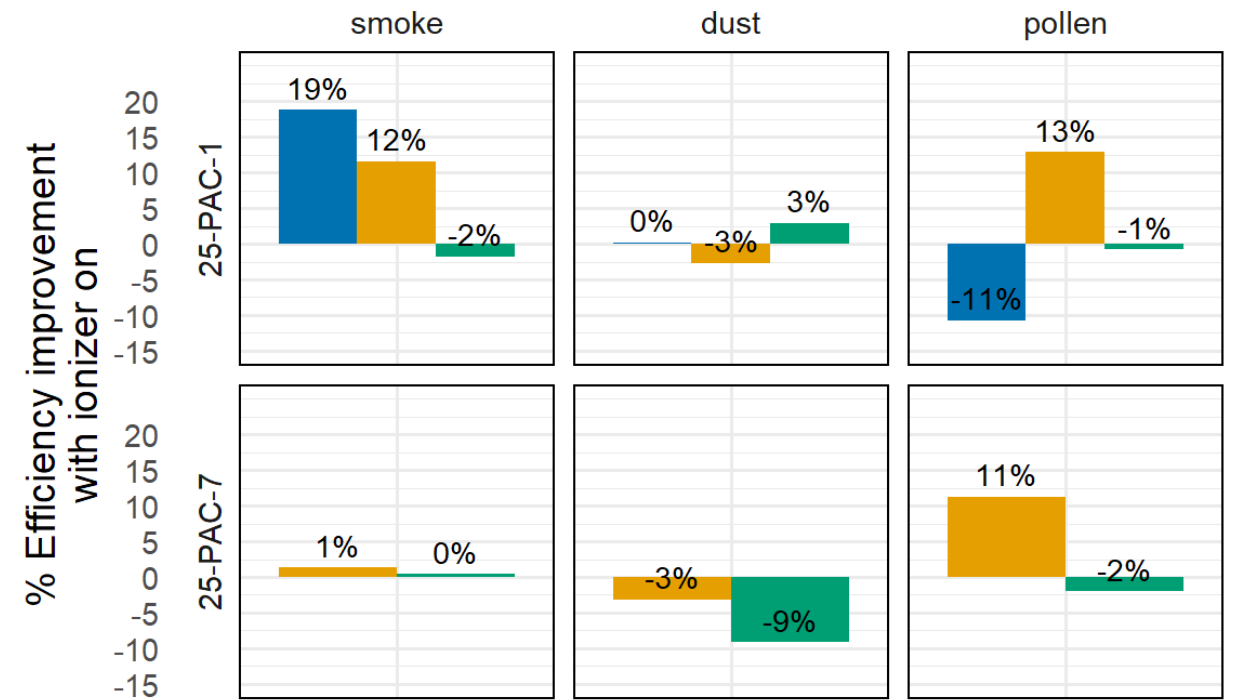

Efficiency: Noticeable improvement to efficiency for 25-PAC-1 for smoke at low and medium setting and pollen medium setting. Impact is varied with sometimes negligible changes in efficiency or even negative impacts to efficiency.

25-PAC-6 App Anomaly

- The device 25-PAC-6 can be operated via a Mobile App or offline.
- In the original test, the lab ran the one of the trials (dust) with the app enabled and the other two trials (smoke and pollen) offline. The power at the highest fan speed was significantly lower during the app enabled trial compared to the other two trials.
- However, the CADRs were comparable across all three trials leading us to wonder how the device could produce a high CADR at a lower power when using the app.

	Offline	With App
Measured Power (W) High Fan	79.0	46.5
CADR High Fan	402.8	417.9

Consistently low throughout the trial (20 minutes), varying between 45 and 50 W, suggesting the lower power was not due to a typical auto mode power reduction

Similar (even higher!) CADR

- We then asked the lab to repeat all trials with the app enabled, but the new results had higher power (~80 W) consistently throughout all tests, making it unclear what caused the variation to occur. It may be some hidden feature of the product that is not advertised.

Fan Layout and Performance Implications

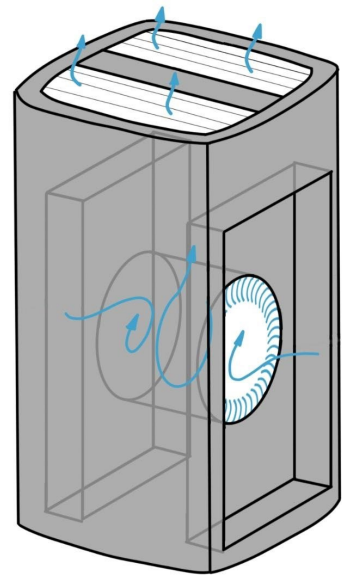

2025-PAC-1

CADR: 503 cfm
Eff: 4.8 cfm/W
Sound: x

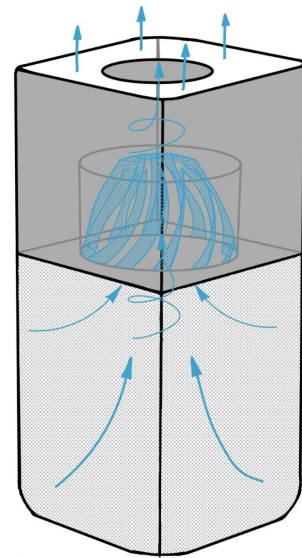

2025-PAC-2

CADR: 413 cfm
Eff: 9.6 cfm/W
Sound: 50 dB

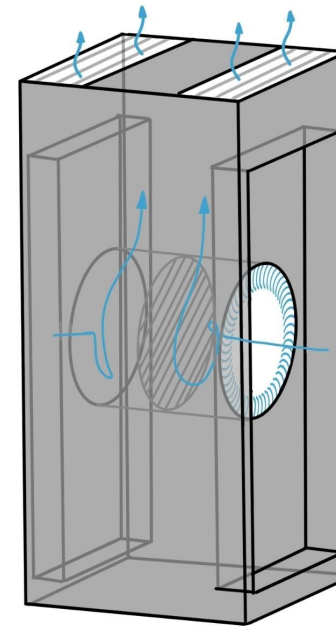

2025-PAC-3

CADR: 476 cfm
Eff: 5.8 cfm/W
Sound: 64 dB

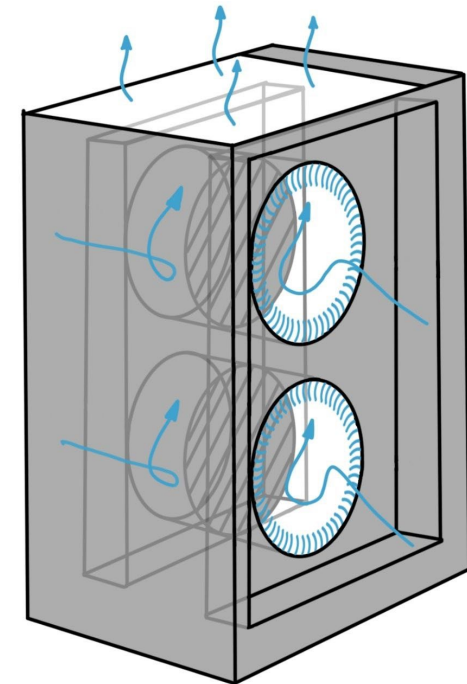

2025-PAC-4

CADR: 562 cfm
Eff: 9.1 cfm/W
Sound: 46 dB

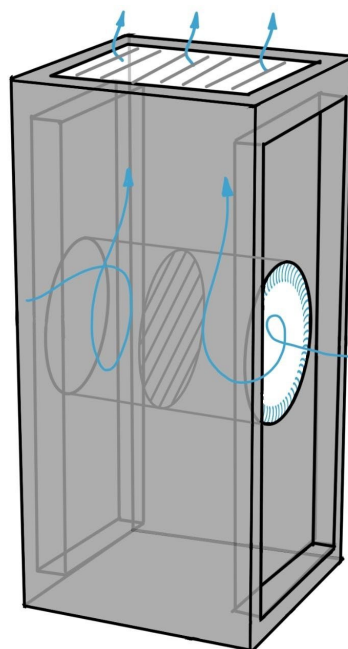

2025-PAC-5

CADR: 484 cfm
Eff: 5.9 cfm/W
Sound: 67 dB

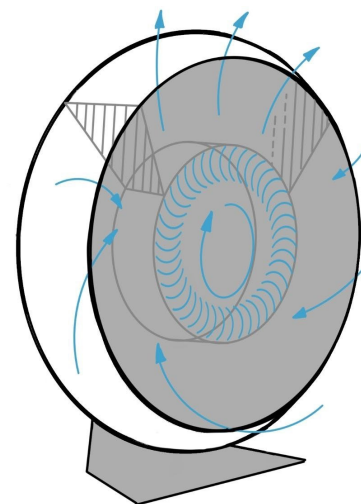

2025-PAC-6

CADR: 403 cfm
Eff: 5.2 cfm/W
Sound: x

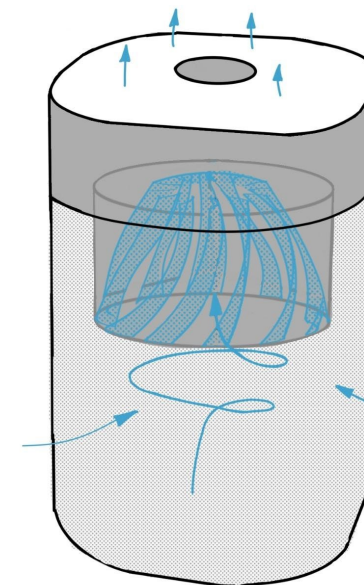

2025-PAC-7

CADR: 335 cfm
Eff: 7.1 cfm/W
Sound: 55 dB

Fan Layout and Performance Implications

ID	Measured Efficiency	Rated Sound (dB) / CADR	Fan Features	Comments
25-PAC-1	4.8	Not Available	1 centrifugal fan, dual inlet with <u>no</u> center separator	No center separator in fan axis may explain lower efficiency than the centrifugal fans with center separator
25-PAC-2	9.6	0.12	1 mixed-flow (axial + centrifugal) fan, 360° intake	Combination of axial and centrifugal components may explain higher efficiency
25-PAC-3	5.8	0.13	1 centrifugal fan, dual inlet with center separator	Medium efficiency and sound compared to other products, similar to 25-PAC-5
25-PAC-4	9.1	0.08	2 centrifugal fans in series, each dual inlets with center separator	Fans in series would not be expected to have higher efficiency or lower sound
25-PAC-5	5.9	0.14	1 centrifugal fan, dual inlet with center separator	Medium efficiency and sound compared to other products, similar to 25-PAC-3
25-PAC-6	5.2	Not Available	1 cross-flow fan with radial inlet and outlet	Cross-flow function may be a factor for low efficiency
25-PAC-7	7.1	0.16	1 fan, maybe free-running centrifugal or mixed-flow, 360° intake	Combination of axial and centrifugal components may explain higher efficiency

Note: Detailed fan specs are not available for these products so the information in this table is based on observations of the products and engineering judgment.

- We did not measure pressure drop across filter media or the free area of the outlet for this study, which are additional factors in efficiency (area for future research).

Conclusions

- What is the relationship between clean air delivery and energy across a range of products? What is the general decrement in CADR as a result of operating at lower fan speeds? How does the efficiency (CADR/W) change with fan setting?
 - CADR drops off steeply at low power levels and plateaus at higher power levels across all products. Middle fan speed settings may be a good compromise for a better point on the efficiency curve; however, the coverage may be only 40-60% of the rated room area. The lowest fan setting is the most efficient but may only cover 15-30% of the rated room area.
- How might the multiple units at lower power compare to fewer, larger units at full power in terms of energy efficiency and total cost?
 - Multiple devices at a medium fan setting are more efficient and reduce utility costs compared to fewer devices at high fan setting; however, the additional upfront costs and filter replacement costs tend to even things out and it becomes product dependent. The assumed filter replacement frequency has a big impact on the results, with more frequent replacements favoring the fewer devices on high fan setting scenario.

Conclusions

- How do the measured CADR, power, and efficiency compare to the manufacturer specs?
 - **CADR:** Most results were very similar to specs (<5% variation), excluding the pollen tests because values above 450 cfm are not reported according to AHAM-AC-1. Two products performed somewhat worse on both smoke and dust tests (-9% and -13% for one product and -12% and -17% for the other). One product performed notably worse on smoke (-11% compared to specs) but not dust and one other performed notably worse on dust (-12%) but not smoke. No products performed better than 5% compared to specs on any test.
 - **Efficiency:** Three of the seven products performed very similar to the rated efficiency (<3% variation). Two of the remaining four products performed slightly better than the rated values (both +8%) and the other two performed slightly worse (-7% and -10%).

Conclusions

- Which products perform better? Are there product attributes that can be identified that might contribute to better performance?
 - The low sample size of devices, high variety of product attributes, and large number of confounding factors for efficiency make it difficult to draw conclusions for this question. A few factors that were observed that could possibly explain some of the variations in efficiency across products:
 - ✓ The one centrifugal dual inlet fan with no center separator, which would not be expected to have a high efficiency, had a lower efficiency than the dual inlet fans with a center separator
 - ✓ The two devices with a combination of axial and centrifugal components and 360° intake had two of the highest efficiency results
 - ✓ Contrary to what was expected, the device with two fans in series had a high efficiency or low sound rated
 - ✓ The one device with a cross-flow fan, which does not typically have high efficiency, had one of the lowest efficiency values

Other Conclusions / Future Research Ideas

- Filter replacement costs can be significant (58% - 67% of 5-year life cycle costs)
 - Future research with industry to optimize filter replacement frequency based on cleanliness of environment, operation time and settings, and other factors
- These products were all tested in new condition, but performance can vary over time and potentially differently between products
 - Future research to investigate load up on filters and performance over time
- More devices on medium fan setting may be a more affordable option to reach clean air targets than fewer devices on higher fan setting in many scenarios
 - Future research to investigate the interactive effects of having multiple PACs in one room in terms of CADR and sound (both sound level and other attributes)
 - Future research can also investigate how placement of the units affects performance and the evaluation of ceiling air filtration units as an alternative technology
- This is a small sample size to link performance to fan and other device attributes definitively
 - Future research to measure pressure drop, filter characteristics, and other parameters that would be attributed to efficiency and noise on a larger sample of products