

INTERDEPENDENCIES

During disruptions (cyber-attack, power loss, network outages), backup communication methods are essential.

Use the **PACE** acronym to plan for disruptions of mission essential communications or other critical systems and functions.

PRIMARY

- ▶ Best method of communication (Consider machine-to-human and machine-to-machine communications, too!)
- ▶ Examples: E-mail, SCADA, situational awareness, information sharing, etc.

ALTERNATE

- ▶ Common but less optimal
- ▶ Examples: Cell phones, text

CONTINGENCY

- ▶ May not be as fast, convenient or reliable, but can accomplish the task
- ▶ Examples: Satellite phones, radios

EMERGENCY

- ▶ Last resort, may cause delays in operations
- ▶ Examples: Runners (people), local broadcast (speakers), pen & paper

Resiliency

Ensure alternate, contingency, and emergency replacements are resilient to threats that deny primary communications and systems.

























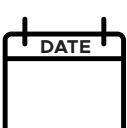









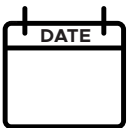

U.S. DEPARTMENT
of **ENERGY**

Office of Cybersecurity, Energy Security,
and Emergency Response



1. Create a **list of essential sector contacts**, consider cross-sector organizations (utilities, telecom, fuel suppliers, key vendors, government).
2. Circle the lock or clock if a method is secure or time sensitive and note date of last update in the calendar box.
3. Maintain **offline copies** of this list, update it, and print copies regularly.

	_____			_____	
	_____	 		_____	 
	_____			_____	
	_____			_____	
	_____	 		_____	 
	_____			_____	
	_____			_____	
	_____	 		_____	 
	_____			_____	

Source: https://www.cisa.gov/sites/default/files/2024-10/2024_NCSWICPTE_Leveraging_PACE_Plan_Emergency_Comms_Ecosystems.pdf