



PNNL's Lab-on-a-Fish is a multi-functional, miniaturized tag that provides valuable information on the health, behavior, and environment of fish and small aquatic species.

LAB-ON-A-FISH

Underwater monitoring system advances knowledge about aquatic species and their environment

TELEMETRY TAG COMBINES HEALTH, BEHAVIOR, AND ENVIRONMENT SENSORS

Pacific Northwest National Laboratory (PNNL) invented the world's first biotelemetry tag that combines edge computing with wireless sensing of *in vivo* physiology (electrocardiogram, electromyogram), behavior (activity level, tail beat frequency), and ambient environment (temperature, pressure, and magnetic field).

Lab-on-a-Fish simultaneously evaluates and monitors the health, behavior, and environment of fish or small aquatic species. The tag is a miniaturized underwater monitoring system that measures animal behavior (acceleration and gyration); physiology (electrocardiogram and electromyogram); and environmental parameters (temperature, pressure, and magnetic sensor.)

Lab-on-a-Fish provides critical information about the physiology, behavior, and ecology of wild aquatic animals in challenging locations where other devices have been limited.

Its ability to store and transmit historical sensor data on both environmental parameters and bioactivity offers valuable information for studying fish behavior and response, as well as for conservation and sustainability studies. Raw data on the health, behavior, and environment of the tagged animal is transmitted in real-time and stored using on-board flash memory.

TECHNOLOGY FEATURES

- Real-time simultaneous monitoring: Uses electrocardiogram and electromyogram, motion, temperature, and pressure
- Small, lightweight: Weighs 2.4g with dimensions of 5.5mm by 6.5mm by 33mm
- Multi-functional tag: Assesses animal health, behavior, and environmental monitoring in one tag
- *In situ* measurements: Remote evaluation of aquatic animals in their natural state
- Applicable to marine, estuarine, and freshwater species: Suitable for sensing and evaluating all small aquatic species

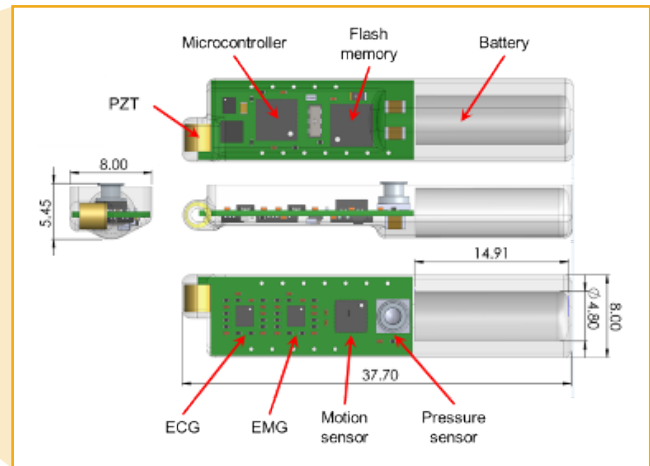
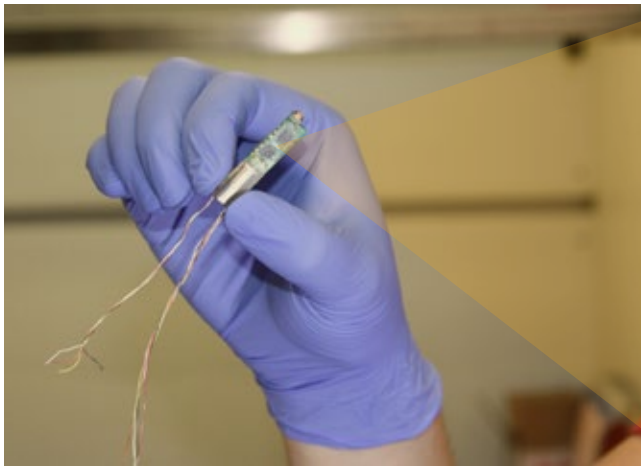

Lab-on-a-Fish can be used in a wide array of study applications, including sustainability and conservation research.

The technology also provides the 3-D locations of a tagged fish or other aquatic animals, acting as an autonomous mobile sensor package that associates sensor readings with specific locations.

ENSURING SAFE FISH PASSAGE

For decades, the hydropower industry has faced the challenge of providing efficient, renewable energy to the electric grid while ensuring safe fish passage. Over the last two decades, biotelemetry tags have evaluated what fish experience as they pass through hydropower dams. However, existing tags are often bulky and do not provide a complete understanding of fish behavior and physiology.

LAB-ON-A-FISH: SMALL AND POWERFUL

Lab-on-a-Fish offers solutions to problems that have plagued existing underwater monitoring systems.

Unlike other technologies, Lab-on-a-Fish is smaller and has greater sensing potential.

The tag weighs only 2.4 g with dimensions of 5.5 mm by 6.5 mm by 33 mm and can be used for as long as eight months. Lab-on-a-Fish has demonstrated its sensing potential for biological and environmental applications in long-term validation in three species: rainbow trout, white sturgeon, and walleye.

This high-performance technology is a 16-bit microcontroller system that can be customized, upgraded, and reused. The hardware includes a thin, multi-layer printed circuit board, integrated sensors and peripherals, a piezoelectric transducer, and a PNNL-developed microbattery. Lab-on-a-Fish uses the MPLAB X IDE platform and the C and Assembly programming languages.

The Lab-on-a-Fish incorporates motion sensors and onboard data processing algorithms for real-time behavioral

monitoring. These motion sensors record surging motion as the animal moves forward and backward, side to side, and up and down. Motion signals recorded in testing on walleye, sturgeon, and rainbow trout demonstrated different behavior patterns can be easily distinguished, including resting, startle response, freely swimming, burst swimming, speeding up, and stopping.

Measurement data are collected and processed in real-time, stored, and transmitted through wireless acoustic communication. Data is stored in the flash memory after the data is stored and collected.

INDUSTRY APPLICATIONS

The scalable manufacturing offers immediate opportunities for broad distribution in the fishery, marine biology, and conservation communities. This technology is ideal for ecologists and dam owners and operators interested in improving fish passage at hydraulic structures.

Lab-on-a-Fish is also a valuable tool for studying health and behavior in all freshwater and marine species.

AVAILABLE FOR LICENSING

PNNL is actively seeking commercial licensees in all fields. Interested parties are encouraged to contact us to explore Lab-on-a-Fish collaboration opportunities.

LET'S CONNECT

If you have questions, please contact:

Sara Hunt

COMMERCIALIZATION MANAGER
206.528.3535 | sara.hunt@pnnl.gov

availabletechnologies.pnnl.gov