



Pacific Northwest
NATIONAL LABORATORY

Proudly Operated by Battelle Since 1965

Tests of a High Temperature Sample Conditioner for the Waste Treatment Plant LV-S2, LV-S3, HV-S3A and HV-S3B Exhaust Systems

JE Flaherty
JA Glissmeyer

March 2015

DISCLAIMER

This report was prepared as an account of work sponsored by an agency of the United States Government. Neither the United States Government nor any agency thereof, nor Battelle Memorial Institute, nor any of their employees, makes **any warranty, express or implied, or assumes any legal liability or responsibility for the accuracy, completeness, or usefulness of any information, apparatus, product, or process disclosed, or represents that its use would not infringe privately owned rights.** Reference herein to any specific commercial product, process, or service by trade name, trademark, manufacturer, or otherwise does not necessarily constitute or imply its endorsement, recommendation, or favoring by the United States Government or any agency thereof, or Battelle Memorial Institute. The views and opinions of authors expressed herein do not necessarily state or reflect those of the United States Government or any agency thereof.

PACIFIC NORTHWEST NATIONAL LABORATORY

operated by

BATTELLE

for the

UNITED STATES DEPARTMENT OF ENERGY

under Contract DE-AC05-76RL01830

Printed in the United States of America

Available to DOE and DOE contractors from the
Office of Scientific and Technical Information,
P.O. Box 62, Oak Ridge, TN 37831-0062;
ph: (865) 576-8401
fax: (865) 576-5728
email: reports@adonis.osti.gov

Available to the public from the National Technical Information Service,
U.S. Department of Commerce, 5285 Port Royal Rd., Springfield, VA 22161
ph: (800) 553-6847
fax: (703) 605-6900
email: orders@ntis.fedworld.gov
online ordering: <http://www.ntis.gov/ordering.htm>



This document was printed on recycled paper.

(9/2003)

Tests of a High Temperature Sample Conditioner for the Waste Treatment Plant LV-S2, LV-S3, HV-S3A and HV-S3B Exhaust Systems

JE Flaherty
JA Glissmeyer

March 2015

Test Specification:	N/A
Work Authorization:	WA# 009
Test Plan:	TP-WTPSP-052, Rev 0.0
Test Exceptions:	N/A
Test Scoping Statement(s):	NA
QA Technology Level:	Development Research

Pacific Northwest National Laboratory
Richland, Washington 99352

Completeness of Testing

This report describes the results of work and testing specified by test plan TP-WTPSP-052. The work and any associated testing followed the quality assurance requirements outlined in the test specification/plan. The descriptions provided in this test report are an accurate account of both the conduct of the work and the data collected. Test plan results are reported. Also reported are any unusual or anomalous occurrences that are different from expected results. The test results and this report have been reviewed and verified.

Approved:



Reid Peterson
Program Manager

3/18/15

Date

Summary

Tests were performed to evaluate a sample conditioning unit for stack monitoring at Hanford Tank Waste Treatment and Immobilization Plant (WTP) exhaust stacks with elevated air temperatures. The LV-S2, LV-S3, HV-S3A and HV-S3B exhaust stacks are expected to have elevated air temperature and dew point. At these emission points, exhaust temperatures are too high to deliver the air sample directly to the required stack monitoring equipment. As a result, a sample conditioning system is considered to cool and dry the air prior to its delivery to the stack monitoring system. The method proposed for the sample conditioning is a dilution system that will introduce cooler, dry air to the air sample stream. This method of sample conditioning is meant to reduce the sample temperature while avoiding condensation of moisture in the sample stream. An additional constraint is that the ANSI/HPS N13.1-1999 standard states that at least 50% of the 10 μm aerodynamic diameter (AD) particles present in the stack free stream must be delivered to the sample collector. In other words, depositional loss of particles should be limited to 50% in the sampling, transport, and conditioning systems. Based on estimates of particle penetration through the LV-S3 sampling system, the diluter should perform with about 80% penetration or better to ensure that the total sampling system passes the 50% or greater penetration criterion.

The testing conducted for this project was part of the River Protection Project—Waste Treatment Plant Support Program under Contract No. DE-AC05-76RL01830 according to the statement of work issued by Bechtel National Inc. (BNI, 24590-QL-SRA-W000-00101, *N13.1-1999 Stack Monitor Scale Model Testing and Qualification*) and Work Authorization 09 of Memorandum of Agreement 24590-QL-HC9-WA49-00001. The internal Pacific Northwest National Laboratory (PNNL) project for this task is 53024, *Work for Hanford Contractors Stack Monitoring*. The testing described in this document was further guided by the Test Plan *Tests of a High Temperature Sample Conditioning System for the Waste Treatment Plant LV-S3, HV-S3A and HV-S3B Exhaust Systems* (TP- WTPSP-052).

The tests conducted by PNNL during 2013 for the high temperature stack conditioning system are described in this report. Two types of tests were performed to evaluate the sample conditioner.

1. Temperature and Humidity Reduction Tests—Performed to evaluate the temperature and humidity reduction achieved by the sample conditioner at prescribed exhaust conditions and dilution rates. These tests serve to inform the sample conditioning process and provide insight for the implementation of the sample conditioner at the WTP facilities.
2. Temperature and Humidity Reduction and Aerosol Penetration Tests— Performed to quantify the penetration of aerosol within the sample conditioner, so that full system penetration estimates can be computed. These tests were performed with several fixed dilution rates in both a vertical and horizontal sample conditioner orientation and at both elevated and room temperatures to evaluate the impacts of these factors on penetration.

The porous tube diluter used as the sample conditioner (Mott Corp, Farmington, CT) provided an effective way to mix cool, dry dilution air with the hot, moist sample air without condensation. Temperature and humidity tests with this diluter revealed that there is an opportunity for condensation formation on the upstream end of the diluter, but that heat tape successfully resolves this. The aerosol penetration tests with the porous tube diluter demonstrated that penetration values were always greater than or equal to 95%, with most values greater than or equal to 98%. The aerosol penetration was

independent of dilution rate, diluter orientation, sample air temperature and humidity conditions, and aerosol size (within the tested range of 8.5 to 12.8 microns).

Acronyms and Abbreviations

acfm	actual cubic feet per minute, an air volume flow unit at actual conditions
AD	aerodynamic diameter
afpm	actual feet per minute, duct velocity at actual conditions
ANSI	American National Standards Institute
APS	aerodynamic particle sizer
ASME	American Society of Mechanical Engineers
BNI	Bechtel National, Incorporated
CAM	continuous air monitor
CCN	correspondence control number
CCP	Computational Computer Program
Cond	Conditioned Air, the output of the sample conditioning system
CFR	Code of Federal Regulations
DEPO	DEPOSITION software code
Dil	Dilution Air
DOE	U.S. Department of Energy
DB	dry bulb temperature
DP	dew point temperature
FIO	For Information Only (non-quality-affecting data)
HDI	“How Do I...?”
HEPA	High-Efficiency Particulate Air
HLW	High-level waste processing facility
HPS	Health Physics Society
HV-S3	Reference to both the HV-S3A and HV-S3B systems, which are expected to have the same temperature and flow conditions
HV-S3A	HLW melter #1 offgas emission unit
HV-S3B	HLW melter #2 offgas emission unit
ISA	instrument service air
LAW	Low-activity waste processing facility
LV-S2	LAW C5V ventilation system emission unit
LV-S3	LAW melter offgas emission unit
MFC	mass flow controller
NQA	Nuclear Quality Assurance
OPC	optical particle counter
PD	physical diameter of aerosol particles
PIC	potential impact category
PNNL	Pacific Northwest National Laboratory

ppb	parts per billion
QA	quality assurance
R&D	research and development
RFU	raw fluorescence units
RH	relative humidity
scfm	standard cubic feet per minute, an air volume flow unit at standard air density (standard conditions used here are 77°F [25°C] and 14.696 psia [101.3254 kPa])
VOAG	vibrating orifice aerosol generator
WTP	Hanford Tank Waste Treatment and Immobilization Plant
WTPSP	Waste Treatment Plant Support Program

Acknowledgments

Preparing, executing, and post-processing these measurements involved a number of Pacific Northwest National Laboratory staff. We would like to particularly acknowledge the support of our quality engineer, Kirsten Meier, and the administrative support of Andrea Boehler, Chrissy Charron, and Mona Champion. We would also like to express our appreciation to scientific staff members Mikhail Pekour and Dan Nelson for their insights and assistance, Norman Anheier for the loan of the aerosol generator, and Brian Riley for microscopy assistance for this project. Additionally, Carmen Arimescu and Elizabeth Golovich provided technical reviews. Megan Peters provided editorial support for this report.

Pacific Northwest National Laboratory is operated for the U.S. Department of Energy by Battelle under Contract DE-AC05-76RL01830.

Contents

Summary	iii
Acronyms and Abbreviations	v
Acknowledgments.....	vii
1.0 Introduction	1.1
1.1 Testing Objectives.....	1.1
2.0 High Temperature Exhaust Systems.....	2.1
2.1 Stack Conditions	2.1
2.2 Sample Conditioning Strategy	2.2
2.2.1 Sample Conditioners	2.3
3.0 Testing Methods	3.1
3.1 Temperature and Humidity Testing	3.3
3.2 Temperature, Humidity, and Aerosol Testing.....	3.7
3.3 Quality Assurance	3.11
4.0 Sample Conditioner Testing Results	4.1
4.1 LV-S3 Test Results	4.1
4.1.1 LV-S3 Temperature and Humidity Tests	4.1
4.1.2 LV-S3 Temperature, Humidity, and Aerosol Tests.....	4.5
4.2 HV-S3A and HV-S3B Test Results	4.6
4.2.1 HV-S3A and HV-S3B Temperature and Humidity Tests	4.7
4.2.2 HV-S3A and HV-S3B Temperature, Humidity, and Aerosol Tests	4.8
4.3 LV-S2 Test Results	4.12
5.0 Conclusions	5.1
5.1 Temperature and Humidity Test Results.....	5.1
5.2 Temperature, Humidity, and Aerosol Test Results	5.1
5.3 Operational Considerations	5.5
6.0 References	6.1
Appendix A LV-S3 Test Data Sheets	A.1
Appendix B HV-S3 Test Data Sheets	B.1
Appendix C LV-S2 Temperature and Humidity Data Sheets.....	C.1
Appendix D Aerosol Aerodynamic Diameter.....	D.1
Appendix E Mott Porous Tube Diluter Quote	E.1
Appendix F Document List.....	F.1

Figures

2.1	Schematic and Photo of Axial Diluter	2.4
2.2	Photos of Condensation Formed Within the Axial Diluter.....	2.4
2.3	Schematic and Photo of Porous Tube Diluter.....	2.6
3.1	Drawing of the Environmental Chamber, Adapted from Thermotron.....	3.2
3.2	Dilution Equipment Set-Up for the Temperature and Humidity Testing	3.5
3.3	Thermocouples and Water Indicator Dots Used in the Diluter for the Temperature and Humidity Testing	3.5
3.4	Equipment Used for the Temperature and Humidity Tests	3.6
3.5	Probes Used for the Particle Injection and Sampling, Enclosed within Flexible Duct during Particle Injection and Sampling.....	3.7
3.6	Equipment Used for the Aerosol Penetration Tests	3.8
3.7	Sample Conditioner with 28-inch Overall Length and 32-inch Overall Length Installed in a Vertical Orientation	3.10
3.8	Fittings and Filter Holder from Vertical Diluter Test Disassembled for Washing and Fluorescence Measurements	3.11
4.1	Water Indicator Dots on the Upstream End and Downstream End of the Diluter	4.5
4.2	Heat Tape Wrapped around Inlet Tube and Upstream End of Housing	4.5
4.3	Light Microscope Image of Oleic Acid Droplets Collected on a Glass Slide with Oleophobic Coating During AP-7.	4.12

Tables

2.1	WTP High Temperature/Humidity Conditions and Flow Rates.....	2.2
2.2	Summary of Instrument Service Air Conditions.....	2.3
3.1	Summary of Example Dilutions for High T/RH Systems.....	3.3
4.1	Estimated Dilution Rates for LV-S3.....	4.1
4.2	Summary of Temperature and Humidity Reduction Tests for LV-S3 Conditions	4.3
4.3	Summary of Aerosol Penetration Tests for the LV-S3 Conditions.....	4.6
4.4	Estimated Dilution Rates for HV-S3A and HV-S3B.....	4.7
4.5	Summary of Temperature and Humidity Reduction Tests for the HV-S3 Conditions	4.8
4.6	Summary of Aerosol Penetration Tests for the HV-S3 Conditions	4.10
4.7	HV-S3 AP-7 Particle Sizes from APS, Glass Slide	4.12
4.8	Estimated Dilution Rates for LV-S2. Rates in parentheses were not used in tests.	4.12
4.9	Summary of Temperature and Humidity Reduction Tests for the LV-S2 Conditions	4.13
5.1	Summary of Temperature and Humidity Test Results.....	5.3
5.2	Summary of Temperature, Humidity, and Aerosol Test Results.....	5.4

1.0 Introduction

According to current Bechtel National, Inc. (BNI) designs (CCN244088, CCN 244647, CCN 179069, and CCN 228831), the exhaust streams from the LV-S2, LV-S3, HV-S3A and HV-S3B exhaust systems at the Hanford Waste Treatment and Remediation Plant (WTP) will have elevated air temperature and dew point. At these emission points, exhaust temperatures are too high to deliver the air sample directly to the required radioactivity monitoring equipment. As a result, a sample conditioning system is considered to cool and dry the air prior to its delivery to the aerosol analysis system. The method proposed for sample conditioning is a dilution system that will introduce cooler, dry air to the exhaust air sample. This method of sample conditioning is meant to reduce the sample temperature while avoiding condensation of moisture in the sample stream. Tests were conducted to measure and document the temperature and humidity reduction, as well as the aerosol penetration through the sample conditioning system. These data will be used by BNI to support the air emissions permit for the WTP.

This work was performed by Pacific Northwest National Laboratory (PNNL) as part of the River Protection Project – Waste Treatment Plant Support Program under Contract No. DE-AC05-76RL01830 according to the statement of work issued by Bechtel National, Inc., (BNI 24590-QL-SRA-W000-00101, *N13.1-1999 Stack Monitor Scale Model Testing and Qualification*) and Work Authorization 09 of Memorandum of Agreement 24590-QL-HC9-WA49-00001. The internal PNNL project number for this task is 53024, which is entitled *Work for Hanford Contractors Stack Monitoring*.

1.1 Testing Objectives

The primary objectives of the testing described within this report were to perform tests that demonstrate the effectiveness of the sample conditioner, document the dry bulb (DB) and dew point (DP) temperature of the incoming sample and outgoing conditioned sample for several representative test cases, and experimentally determine the penetration of aerosol through the sample conditioner as a function of stack condition (which directly impacts dilution rate) and conditioner physical orientation. The target temperature for the sample conditioning was 120°F (50°C) or less, which is the rated temperature limit of the continuous air monitor (CAM) for these stacks. The record sampler has a temperature limitation of 150°F (65°C), so the more conservative 120°F was used for these tests.

Implicit in this test objective is that an appropriate sample conditioner type would be identified to perform the tests, and insights into dilution system operational considerations would be gained. Test cases were performed to represent particular stack temperature and humidity conditions, along with the necessary dilution flow rates. Temperature and dew point conditions for the dilution air were not controlled for these tests.

The ANSI/HPS N13.1-1999 standard states that at least 50% of the 10 µm aerodynamic diameter (AD) particles present in the stack free stream must be delivered to the sample collector. In other words, depositional loss of particles should be limited to 50% in the sampling, transport, and conditioning systems. The total particle penetration, starting with the shrouded probe in the stack and ending with the CAM or record sampler, is often calculated using software tools such as DEPOSITION 2001a (DEPO; McFarland et al, 2000). This software allows users to identify common elements within the transport system, such as bends, contractions, expansions, and splitters, and calculates deposition estimates that are based on experimental results. The DEPO 2001a code does not consider a dilution system. Therefore,

the tests described in this report will be used to fill in the gap in the deposition analysis. Based on estimates of deposition using the DEPO 2001a code for the LV-S3 sampling system, the diluter should perform with about 80% penetration or better to ensure that the total sampling system passes the 50% or greater penetration criterion.

2.0 High Temperature Exhaust Systems

2.1 Stack Conditions

The four stacks with elevated exhaust temperatures are located in the low-activity waste (LAW) and high-level waste (HLW) processing facilities. The elevated temperature and humidity in the melter offgas exhaust (LV-S3, HV-S3A, and HV-S3B) is caused by the pressure blowers and the wet scrubbers. Other types of abatement equipment in the off gas stream have a lesser influence on the airstream temperature and humidity. The C5V ventilation zone (LV-S2) includes the “caves” where the vitrified waste is poured into canisters, which causes heating of that ventilation stream.

The expected temperature, humidity, and flow conditions for these four stacks, the LV-S2, LV-S3, HV-S3A, and HV-S3B, are presented in Table 2.1 (CCN244088, CCN 244647, CCN 179069 and CCN 228831). The minimum, normal, and maximum stack conditions refer to the expected range of stack temperatures. The HV-S3A and HV-S3B stacks are expected to have the same temperature and flow conditions, so where HV-S3 is used in this document, we refer to both the HV-S3A and HV-S3B systems. Note that, although the relative humidity values do not appear to be particularly high, the LV-S3 and HV-S3 dew point temperatures are between 95 and 139°F. The temperature and humidity was supplied from client-provided documentation, while the DP was calculated. Also note that the flow conditions are independent of the temperature and humidity conditions. The highest temperature condition is not necessarily going to have the highest flow condition; Table 2.1 simply lists the range of expected values for each variable. Due to stack conditions that differ significantly from standard conditions, flow and velocity values are presented in actual cubic feet per minute (acfm) and actual feet per minute (afpm).

The LV-S2 system requires only a record sampler, which is expected to have a temperature limitation of 150°F. Since normal conditions do not require sample conditioning, and high temperatures are expected to occur infrequently, it is our understanding that the sampling system will be shut off when the temperature exceeds 150°F. As BNI’s facility design progresses, this approach may be re-considered, so limited tests that represent the LV-S2 have been performed. The LV-S3 and HV-S3 stacks will have both a record sampler and a CAM, which has a temperature limitation of 120°F.

Table 2.1. WTP High Temperature/Humidity Conditions and Flow Rates

Stack	Stack dia. (inches)	Temp. (°F)	%RH	Dew point (°F)	Flow (acfm)	Velocity (afpm)
LV-S2 ^a normal	60	130	10	56	57,424	2,925
LV-S2 ^a maximum	60	210	6	96	91,364	4,653
LV-S3 minimum	18	185	16.9	114	2,642	1,495
LV-S3 normal	18	243	9.6	135	5,652	3,198
LV-S3 maximum	18	282	5.6	139	6,282	3,555
HV-S3 minimum	12	261	2.3	95	1,910	2,432
HV-S3 normal	12	313	1.7	113	2,559	3,258
HV-S3 maximum	12	365	1.5	133	3,140	3,998

a. Only a record sampler (no CAM) will be installed on the LV-S2 stack.

2.2 Sample Conditioning Strategy

To address the problem of sampling stack exhaust with elevated temperatures, several sampling approaches or mitigation steps were considered. First, the high temperature exhaust flow could be mixed with a lower temperature exhaust flow within the same facility to produce a lower temperature exhaust flow. This option was eliminated by BNI in early discussions. Since the exhausters (fans) are large contributors to the high temperatures within the stack, sampling directly upstream of the fans was also considered. Although the temperature is relatively low this location, the absolute humidity level is still as high as the downstream condition, and the relative humidity is nearly 100%, so sample conditioning would still be needed because of humidity rather than temperature, and sample conditioning would be more challenging due to the high relative humidity, which would readily condense. Furthermore, the duct upstream of the fans is under vacuum, which adds a challenge to sampling. Other locations upstream of the fans were also considered, such as directly downstream of the high-efficiency particulate air (HEPA) filters, after the carbon bed adsorbers, and after the thermal catalytic oxidizer. However, these locations have the added complications of 1) sampling upstream of other abatement equipment, 2) requirements for approval due to deviation from the ANSI/HPS N13.1 standard (which applies to any location upstream of the fans), and 3) triggers additional scale model testing to qualify the sampling location. Therefore, sampling within the stack, which requires a sample conditioner, was deemed to be the necessary approach to deliver the exhaust sample to the required measurement equipment.

Once the need for sample conditioning was established, the method of sample conditioning, as well as the physical equipment used in the sample conditioning, was explored. If the primary objective was to simply reduce elevated temperature, high thermal conductivity piping with water jackets or heat fins could be utilized to reduce the sample gas temperature. However, direct cooling would result in condensation, which not only scrubs some aerosol from the sample stream, but also produces a liquid waste stream that must be drained and disposed to avoid damage to the air sampling equipment. Instead, both a reduction of the dry bulb and dew point temperatures is required. As a result, conditioning through dilution with a low temperature and low DP air stream was selected.

Instrument Service Air (ISA) is produced centrally and distributed to the different buildings at the waste treatment plant, so it is the most readily-available source of dilution air at the plant. Table 2.2 lists the expected range of DB and DP conditions of the delivered ISA (CCN 216991) and is categorized by temperature as Minimum, Normal and Maximum. The ISA conditions influence the amount of dilution air that is necessary to add to the sampled air to meet the target temperature and humidity for the conditioned stack sample. The tests described in this report assume that ISA is available in the plant at the required flow rates to support sample conditioning.

Table 2.2. Summary of Instrument Service Air (Dilution Air) Conditions

Parameter	Minimum	Normal	Maximum
Dry Bulb Temperature	50°F	60°F	80°F
Pressure	90 psig	100 psig	150 psig
Pressure Dew Point (@100 psig)	-60°F	-40°F	-20°F

2.2.1 Sample Conditioners

2.2.1.1 Axial Diluter

Two basic methods to introduce the dilution air to the sample stream were considered. The first was an axial diluter, which comprises an inner tube of stainless steel for the sample stream and an outer stainless steel tube for the dilution stream. The dilution air was introduced into the larger tube through a large tee fitting with the smaller inner tube centered within the tee. Downstream of the terminus of the inner tube, the two air streams would mix longitudinally to produce a conditioned air stream. Figure 2.1 shows a schematic of this diluter (Dekati, Ltd., Kangasala, Finland), along with a photo of the diluter used for testing. Several tests were performed with this axial diluter; however, this diluter type is flawed for this particular application. The dilution air flowed over the inner tube and cooled the inner tube to below the DP of the sample stream, so that moisture in the sample stream condensed along the inner walls of the inner tube. Figure 2.2 shows some photos of condensed water standing within the outer tube of the axial diluter. These photos are looking from the outlet of the outer tube, upstream toward the outlet of the inner tube. Condensation formed within the inner tube, and was transported into the outer tube by the air flow in the tube.

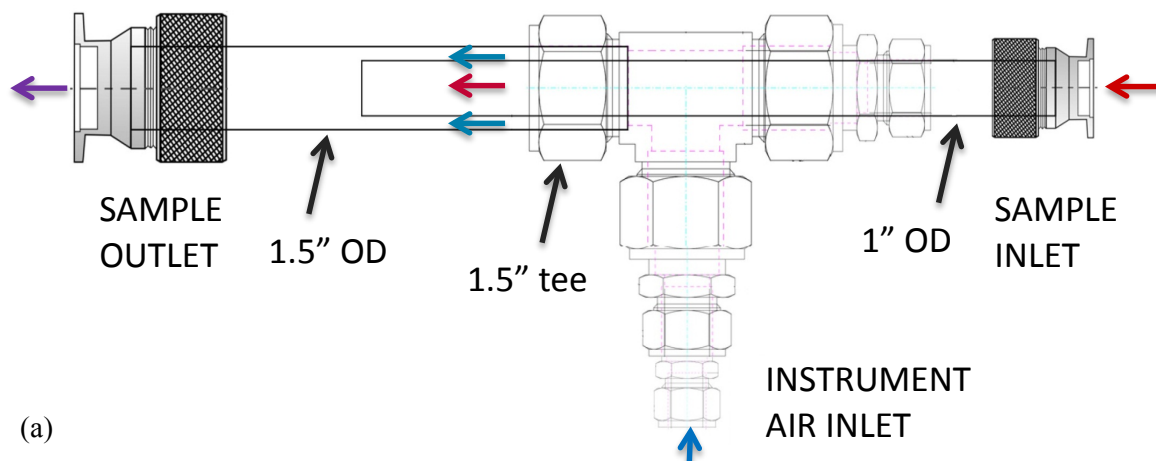

(a)



(b)

Figure 2.1. Schematic (a) and Photo (b) of Axial Diluter

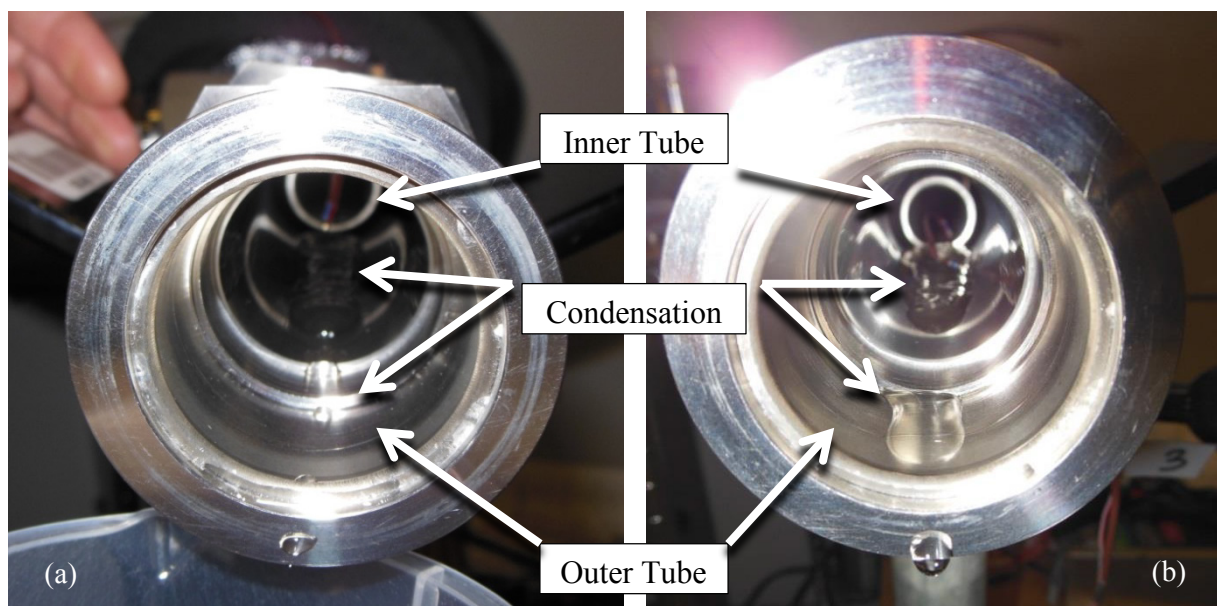

(a)

(b)

Figure 2.2. Photos of Condensation Formed Within the Axial Diluter

This axial diluter could be implemented in one of two configurations to be compatible with these stack conditions. First, two-stage dilution could be utilized. In this configuration, two axial diluters are installed successively. The first uses hot air with low humidity as the dilution air so the sample is conditioned primarily for moisture. The second diluter can then use colder air to reduce the sample temperature without risk of condensation. This approach has several disadvantages, which include additional space requirements to accommodate two diluters, additional equipment (such as mass flow controllers and air heaters) to supply the air for two diluters, and significant overall dilution (which impacts the detection limit). An alternative configuration for the axial diluter is the use of either a low thermal conductivity material for the inner tube or insulation of the stainless steel inner tube so that one diluter can be used to condition the sample stream. An acceptable material for the inner tube could not be identified, so the latter approach was considered and tested, but insulation proved to be insufficient to prevent condensation. The difficulty in insulating the inner tube is that the insulation cannot occupy the entirety of the space between the inner and outer tube, so a relatively thin insulation material is preferred, although the outer tube diameter is most likely increased to accommodate the insulation. Additionally, the insulation should tolerate high temperatures without damage to the material. Testing with several layers of ceramic insulation weave over the stainless steel tube still resulted in cooling of the tube below the sample DP, and condensation formation. As a result, the use of the axial diluter was discontinued for these tests.

2.2.1.2 Porous Tube Diluter

The second diluter was a porous tube diluter, which avoids the problem of condensation observed with the axial diluter by preventing contact between the hot, moist sample stream and the colder walls and by allowing both temperature and moisture dilution to occur simultaneously along the length of the diluter. Figure 2.3 shows both a schematic and a photo of the porous tube diluters (Mott Corporation, Farmington, CT) used in these tests. The light grey portions of the schematic represents solid stainless steel components, while the orange portions represent the sintered steel inner tube. The sample stream enters through a small length of solid stainless steel tube that is welded to a long (24-inch) section of porous (sintered) stainless steel with two-micron pores. This porous tube is enclosed within a solid stainless steel tube, which has an inlet that allows dilution air injection within the annulus between the solid and sintered steel tubes. Dilution air is supplied at a higher pressure than the sample air, which forces dilution air through the porous tubes. The sample air remains within the center region of the porous tube, and does not come into direct contact with the porous tube walls. This diluter is a type that is commercially available, although the size was customized for this application. The diluter used in these tests had a 1.5 inch outside diameter inlet and outlet tube and a $\frac{3}{4}$ inch inlet tube for the dilution air. Although there were instances in which condensation could be formed with this diluter, strategically-placed heat tape readily corrected this problem. As a result, tests described within this report utilize this type of diluter. The 32-inch diluter shown in Figure 2.3 was selected specifically to allow sufficient space for a fitting and good heat tape contact, which was more difficult to achieve with the smaller inlet length of the 28-inch diluter. To purchase a diluter identical to the one used in testing with 32-inch overall length, reference Mott Quote number QU0200669-2, part number 7610S-1.375-24-2-AB. The full description of the item listed in the quote will be necessary to uniquely identify the equipment used in these tests (See Appendix E).

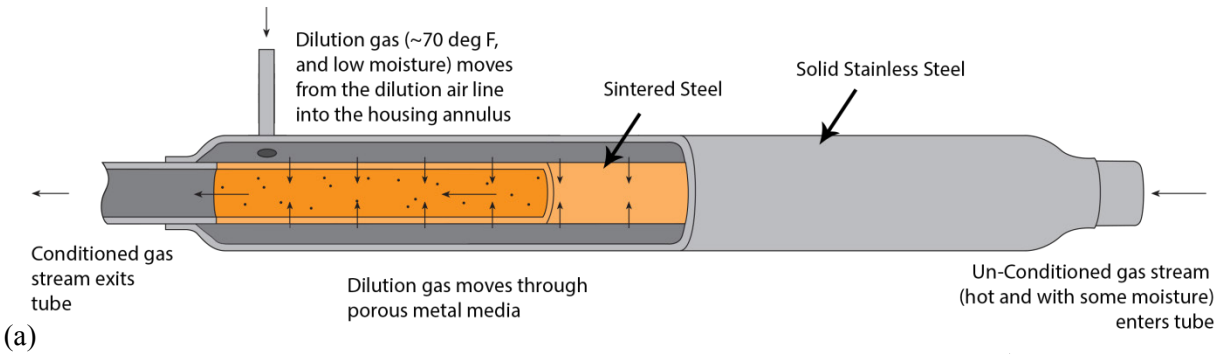

Figure 2.3. Schematic and Photo of Porous Tube Diluter. (a) is adapted from a vendor brochure (Mott Corporation, 2008), and shows the interior structure of the diluter. (b) shows the 28-inch and 32-inch porous tube diluters used for testing.

3.0 Testing Methods

The sample conditioner testing methods were based on the requirements of ANSI/HPS N13.1-1999. A test plan, TP-WTPSP-052, *Tests of a High Temperature Sample Conditions System for the Waste Treatment Plant LV-S2, LV-S3, HV-S3A and HV-S3B Exhaust Systems*, which outlines the testing approach and provides a test matrix of proposed test runs, was prepared by PNNL and approved by BNI. These types of tests had not been performed under this project in the past, so procedures and test instructions did not exist and were not created for the tests. Instead, check-lists to guide the testing steps, and data sheets retained as test data packages were utilized. In addition, a lab record book was used to document exploratory testing or other relevant information that did not fit within the test data package framework. In general, the check-lists were guided by previous studies such as those performed at Texas A&M (Gupta and McFarland, 2001) and at the U.S. Army Edgewood Chemical Biological Center (Kesavan and Doherty, 2000), as well as from aerosol sampler testing procedures outlined in 40 CFR 53, Subpart F.

Two types of tests were performed for the high temperature exhaust sample conditioner. These were the:

1. Temperature and Humidity tests, where the reduction of DB and DP temperature was documented, and the
2. Temperature, Humidity, and Aerosol tests, where the penetration of aerosol for selected temperature and humidity conditions was quantified.

The test plan described the minimum number of tests that were planned for each stack temperature and humidity condition. Additional test runs were performed to improve results, verify results, and bound expected conditions. For each test, an environmental chamber (see Figure 3.1; Thermotron, Holland, MI) was used to supply the sample air at a prescribed temperature and humidity condition, while sample conditioning, aerosol injection, and other equipment were located outside of the chamber. The footprint for this chamber is 5 by 8 feet (~1.5 by 2.4 meters), and it is equipped with flanged ports that allow equipment to be mounted through the chamber walls.

The example dilution rates needed to produce a sufficiently-conditioned air stream were estimated using a psychrometric calculator (PsyCalc, Farmington, CT) and the effluent air and ISA conditions from Table 2.1 and Table 2.2. Both the normal and maximum ISA conditions were used to provide the expected normal and maximum dilution values. Although the temperature limitation of the stack monitoring equipment is 120°F (50°C), the DP is also a practical limitation for the conditioned sample stream. The normal room air temperature for the space where these stack monitors are expected to be housed is 60°F. Therefore, the DP for the sample stream should be less than 60°F to ensure that condensation does not form along the walls of the transport tubing. In many cases, the dilution value was driven by the DP constraint rather than the DB temperature constraint.

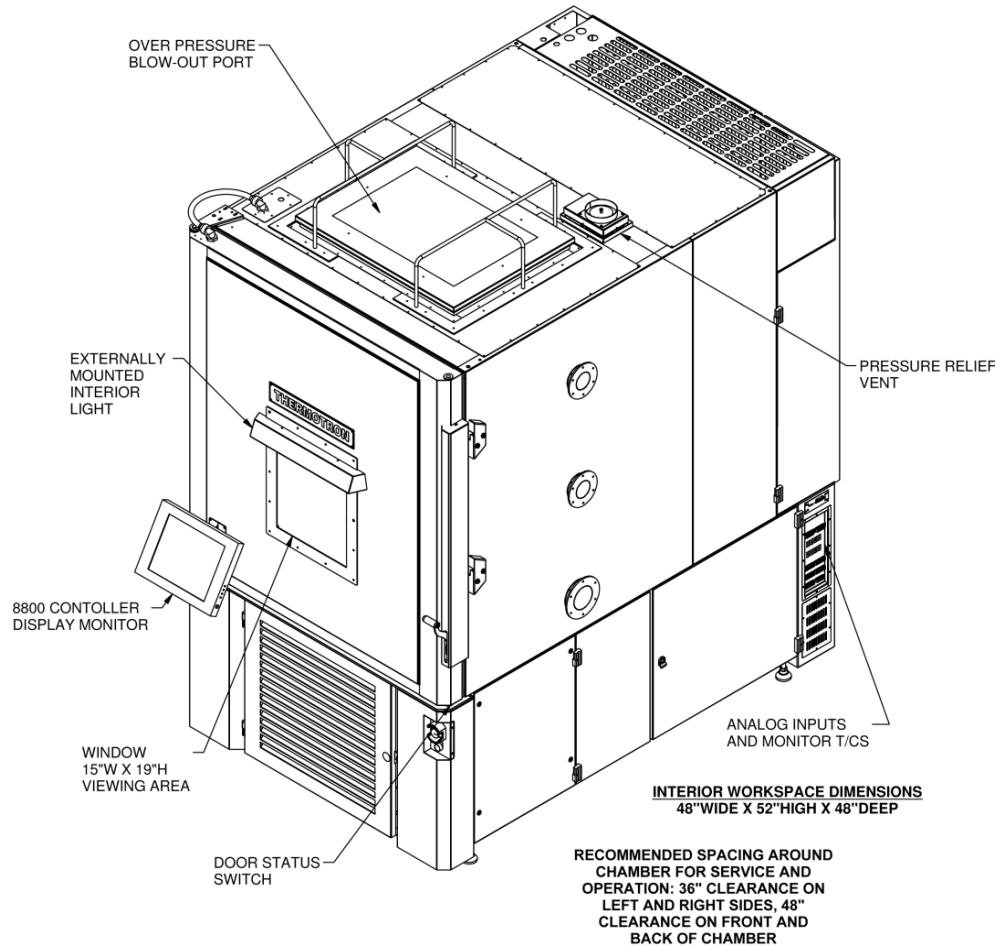

Figure 3.1. Drawing of the Environmental Chamber, Adapted from Thermotron (2009).

Table 3.1 summarizes estimated dilution values for each stack condition. These values should be treated as approximations. The flow rate from the stack was always assumed to be 1.3 acfm, which is the flow rating of the shrouded probe (Model RF37-007) anticipated for use with the CAM. This shrouded probe was selected based on discussions with BNI, which pointed to the use of the Lab Impex Systems SmartCAM, which is typically operated at 1.3 acfm (Lab Impex, Datasheet L236D). The target condition was either a DP temperature less than 60°F or a DB temperature less than 120°F. “Dil” represents the dilution air, while “Cond” represents the conditioned air. The difference between the conditioned air and dilution air rate is the flow rate from the chamber or stack, which should equate to 1.3 acfm, converted to scfm units (standard conditions are 77°F [25°C] and 14.696 psia [101.3254 kPa]).

The two sample conditioner test methods are described below in Sections 3.1 and 3.2. The QA program that is implemented for this project is described in Section 3.3.

Table 3.1. Summary of Example Dilutions for High T/RH Systems

Stack	Temp °F	Dew Pt °F	Norm ISA (60°F DB/-40°F DB)				Max ISA (80°F DB/-20°F DP)			
			Dil (scfm)	Cond (scfm)	Cond DB (°F)	Cond DP (°F)	Dil (scfm)	Cond (scfm)	Cond DB (°F)	Cond DP (°F)
LV-S2 ^a norm	130	56	0.48	1.65	109.9	47.5	0.79	1.96	110.0	43.4
LV-S2 ^a max	210	96	2.48	3.46	104.9	59.9	5.08	6.09	110.0	53.3
LV-S3 min	185	114	5.09	6.06	85.3	59.9	5.19	6.16	98.4	59.9
LV-S3 norm	243	135	9.05	9.87	78.7	59.9	9.26	10.07	96.3	59.8
LV-S3 max	282	139	9.76	10.52	80.2	59.9	9.97	10.72	98.1	59.8
HV-S3 min	261	95	2.39	3.31	118.8	58.6	3.61	4.53	118.9	50.7
HV-S3 norm	313	113	4.07	4.88	107.1	59.9	4.63	5.44	119.0	57.4
HV-S3 max	365	133	7.42	8.13	92.4	59.9	7.63	8.34	109.8	59.9

a. Only a record sampler (no CAM) will be installed on the LV-S2 stack

3.1 Temperature and Humidity Testing

The temperature and humidity tests were performed to evaluate the sample conditioner performance at different stack conditions and dilution rates. Acceptable performance is that the sample stream temperature and DP is reduced so that the sample may be delivered to the necessary monitoring equipment. Aerosol in the sample stream may be “scrubbed” by condensed water, and an excess of water may damage monitoring equipment components, so condensation should be avoided.

In these tests, a simulated sample stream, supplied by the environmental chamber, was sampled with a shrouded probe within the chamber, transported through the wall of the chamber, and diluted with a dry airstream at approximately room temperature through the porous tube diluter. This diluter was selected for the advantage that temperature and humidity reductions occur simultaneously along the length of the diluter without any substantial “cold spots” where condensation might occur. During testing, however, condensation formation was observed at the upstream end of the diluter, presumably due to the colder air within the solid, outer stainless steel tube cooling the solid portion of the diluter inlet tube, where the sample is in contact with the solid tube wall. As a result, heat tape was applied over the upstream fitting, inlet, and first few inches of the diluter housing to prevent condensation.

An overview of the testing apparatus used in the temperature and humidity reduction test is shown in Figure 3.2. The dilution air stream (indicated with light blue arrows in Figure 3.2) was delivered from an air compressor and was dried using a desiccant drying system. This was a simple system, utilized for these tests primarily due to its low cost. The object of this drying system was not to simulate the conditions of the ISA at the WTP, but to simply supply a sufficiently dry and cool dilution stream to test the operation of the diluter. The dried air conditions were measured to document the test conditions. A Vaisala (Woburn, MA) DP sensor (labeled in Figure 3.2 and Figure 3.4) was used to measure the DP, while a thermocouple (labeled in Figure 3.2) was used to measure the temperature. The dilution air flow rate was controlled with an Alicat (Tucson, AZ) mass flow controller (MFC).

During these tests, the estimated target dilution rates (see Table 3.1) were used, and the temperature and humidity of the sample air, dilution air, and conditioned air was measured and recorded. In addition, a profile of the temperature reduction along the length of the diluter was obtained with the installation of thermocouples within the diluter itself. Typically, four thermocouples were installed, each within or just upstream of the diluter. This included a centerline air temperature measurement near to the outlet of the diluter, a centerline measurement near the longitudinal center of the diluter, and a wall temperature near the weld seam between the solid and porous tubes on the upstream end of the diluter. Some tests also included a centerline measurement in the fitting just upstream of the diluter. Figure 3.3 shows the thermocouples installed in the upstream end of the diluter as well as the centerline thermocouple at the downstream end of the diluter.

Tests also often included water indicator dots (3M, Saint Paul, MN), which change color irreversibly from white to red when water contacts them. At sufficiently high temperatures, the dye in these dots becomes fixed, and the dots are no longer effective for detecting condensation. Therefore, an additional measure, marking the solid portion of tubing with water soluble marker, was utilized to determine whether water was in contact with the walls of the diluter. Each temperature and humidity reduction test was approximately 1 hour in duration to allow potential condensation droplets to accumulate so they may be detected by one of the methods described above.

The conditioned air (downstream of the diluter) temperature and humidity was measured using a Vaisala relative humidity sensor (labeled in Figure 3.2 and Figure 3.4). The total conditioned air stream was controlled with an Alicat mass flow controller as shown in Figure 3.4 with a vacuum supplied by two 10 acfm rotary vane vacuum pumps (Gast Manufacturing, Benton Harbor, MI). The sample flow rate from the chamber is calculated as the difference between the conditioned air flow and the dilution air flow. The downstream MFC was typically protected from spurious condensation or particulates with a glass fiber filter and a 40 μm sintered metal filter.

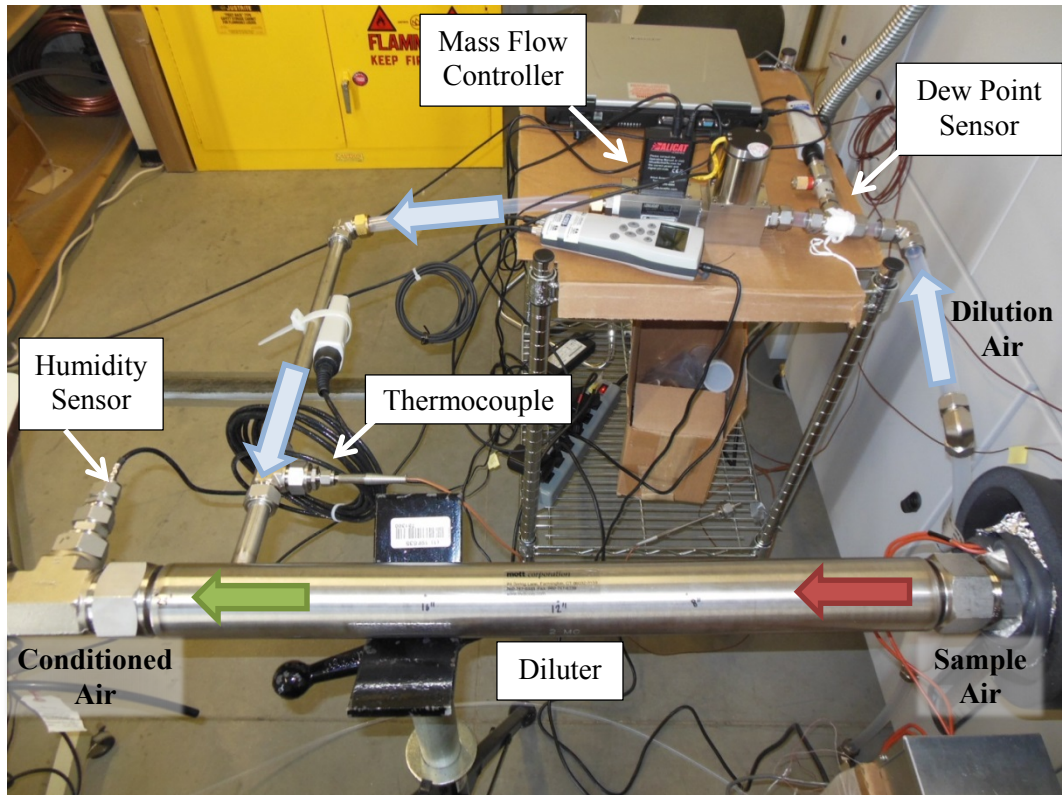

Figure 3.2. Dilution Equipment Set-Up for the Temperature and Humidity Testing. Light blue arrows represent the dilution air flow, the red arrow represents the hot sample air, and the green arrow represents the conditioned air.

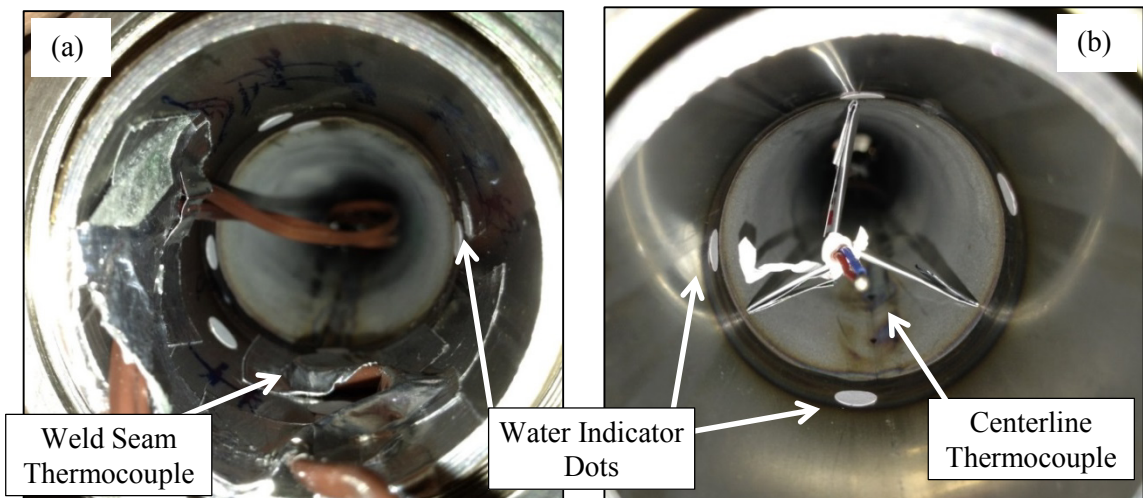

Figure 3.3. Thermocouples and Water Indicator Dots Used in the Diluter for the Temperature and Humidity Testing

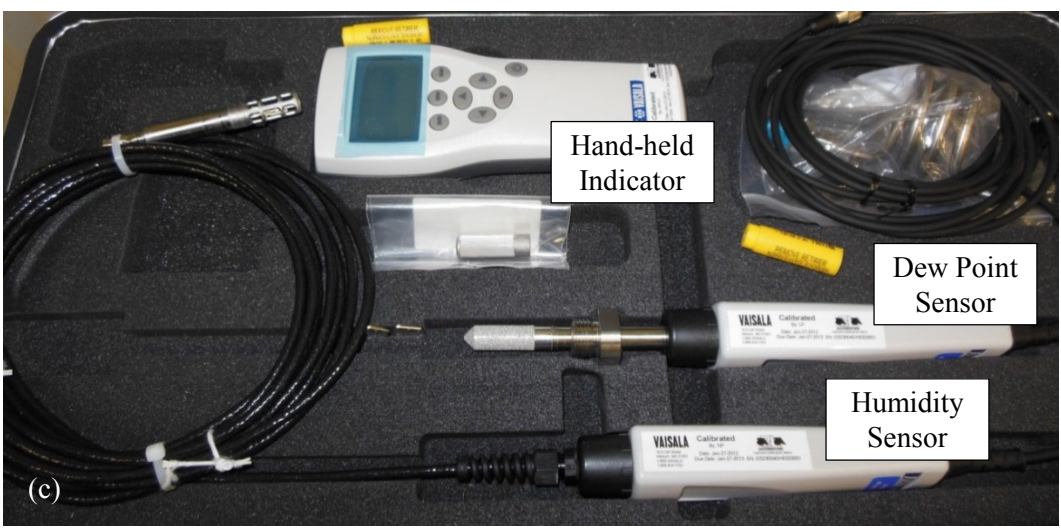
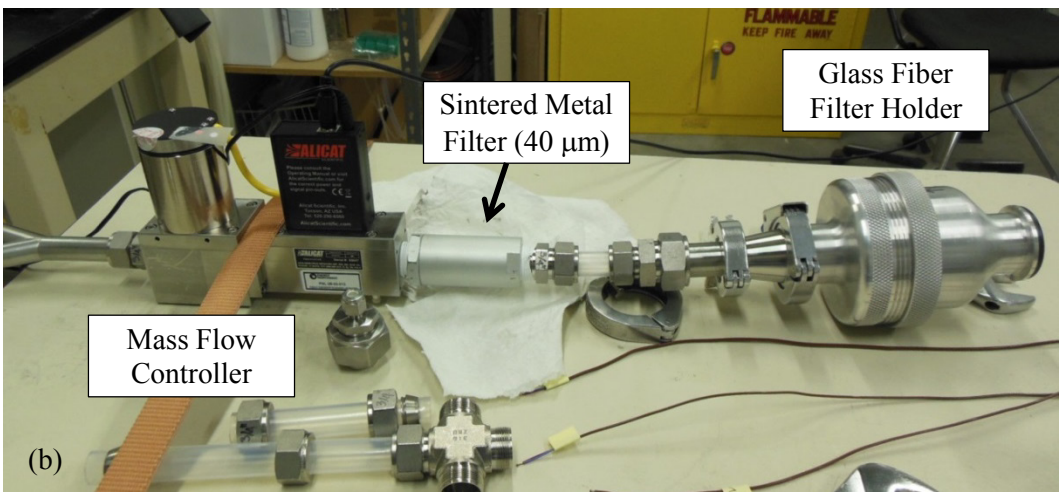
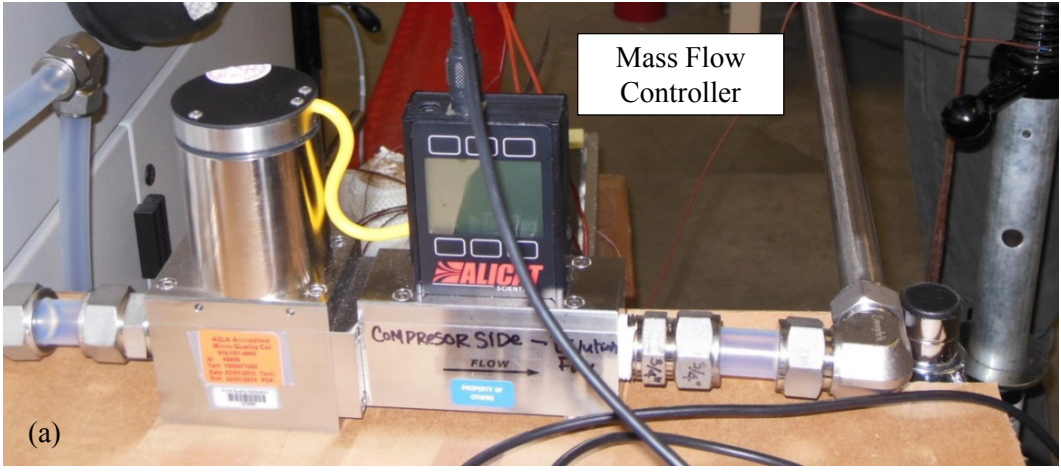

Figure 3.4. Equipment Used for the Temperature and Humidity Tests

3.2 Temperature, Humidity, and Aerosol Testing

The second type of sample conditioner test evaluated the aerosol penetration through the diluter. Typically, in these tests, aerosol in the range of 9 to 11 micrometer aerodynamic diameter (AD) were generated with a TSI Inc. (Shoreview, MN) vibrating orifice aerosol generator (VOAG), injected into the environmental chamber, and sampled by a shrouded probe equipped with the sample conditioning system downstream of the sample transport line. Figure 3.5 shows the aerosol injection probe and shrouded probe installed within the chamber. When tests were performed, a flexible duct was installed with one end near the chamber fan, the other end over the shrouded probe, and the aerosol injection probe installed through the wall of the flexible duct. This arrangement ensured that the aerosol was not diluted within the full volume of the chamber, and instead, directed the aerosol into the shrouded probe. Temperature measurements at the shrouded probe tip indicated that the air entering the shrouded probe under this configuration was consistent with the overall chamber air conditions.

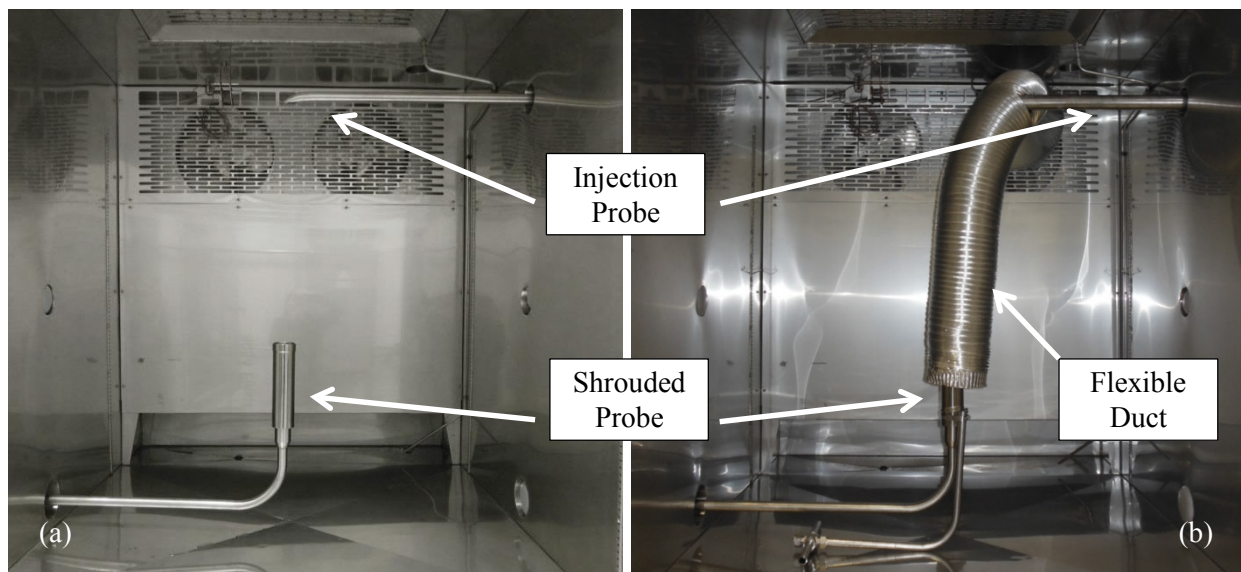

Figure 3.5. Probes Used for the Particle Injection and Sampling (a), Enclosed within Flexible Duct during Particle Injection and Sampling (b)

The aerosol produced for these tests was nominally monodisperse (single size, rather than a size distribution) oil droplets (oleic acid) tagged with a fluorescent tracer (fluorescein) to quantify the aerosol deposition. The particle size coming out of the VOAG was measured using either a TSI Inc. (Shoreview, MN) aerodynamic particle sizer (APS) or a Hach (Elgin, IL) optical particle counter (OPC) during the test to ensure that particles were produced throughout the duration of the test, and to ensure that particle sizes remained within the expected size range¹. Figure 3.6 shows a typical aerosol production/ measurement/ injection set-up during an aerosol penetration test. The VOAG, with its aerosol drying column equipped with a 20 mCi Kr-85 particle charge neutralizer (instrument on the right in Figure 3.6 (a)), is connected to the stainless steel injection probe (covered in insulation in Figure 3.6 (a)). A tee on the injection probe allows the APS (instrument on the left in Figure 3.6 (a)) to sample for particle sizing and concentration.

¹ The APS measures the mean and standard deviation of the AD directly. The OPC measures an optical size equivalent to the diameter of a polystyrene latex sphere, used for calibration. The OPC data has to be reduced to estimate the mean and standard deviation AD.

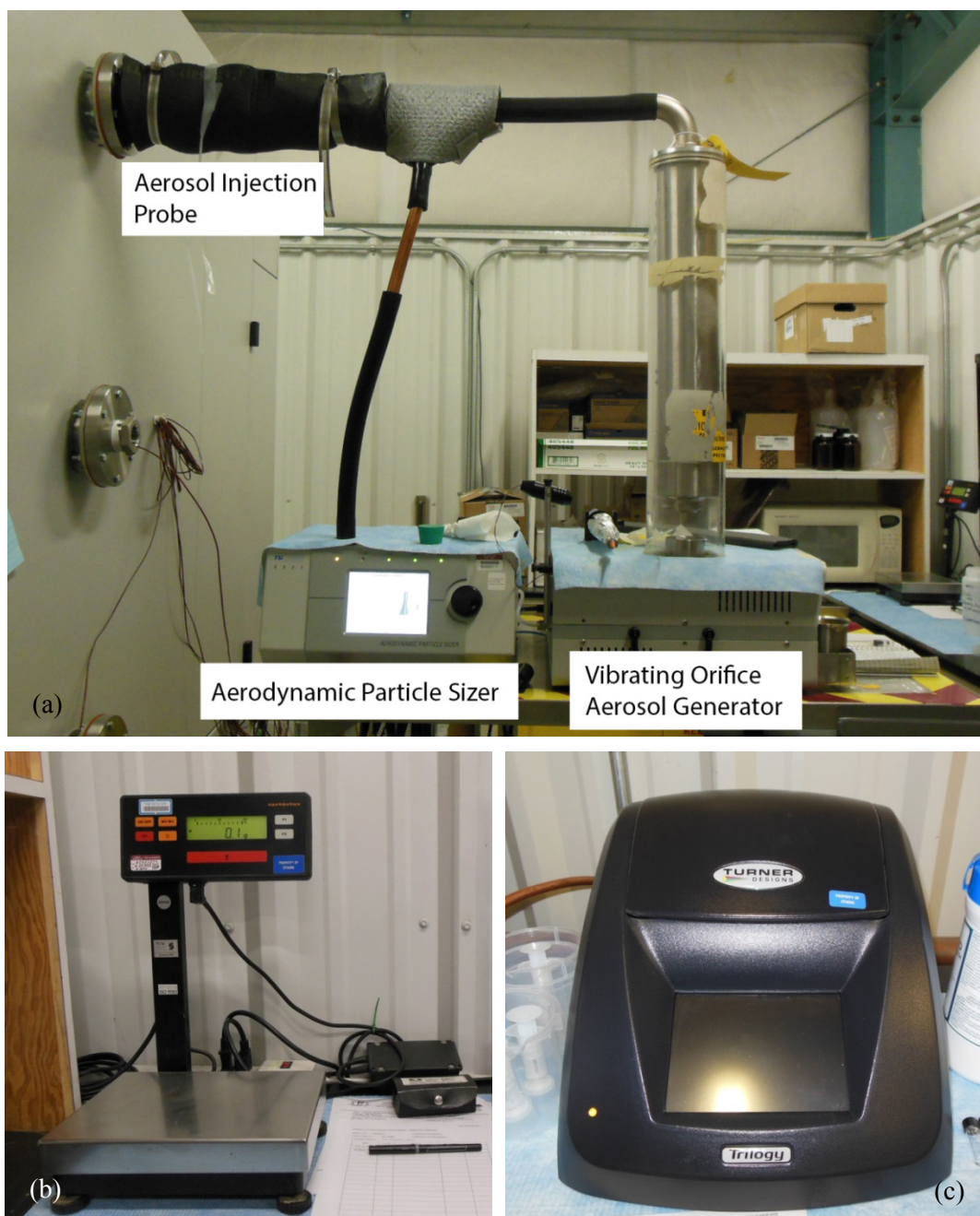

Figure 3.6. Equipment Used for the Aerosol Penetration Tests. (a) Aerosol generation, measurement, and injection set-up, (b) platform scale used to measure solvent mass, and (c) fluorometer.

During some tests, glass slides coated with Novec 1720 oleophobic electronic grade coating from 3M (Saint Paul, MN) were placed within the environmental chamber to collect particles. The particles are not completely flattened on the slide with oleophobic coating, and instead, only flatten slightly. Olan-Figueroa et al (1982) describe the flattening coefficient for oleic acid droplets on a similar (but not identical) coating material. For comparison with the APS and OPC data, the droplets deposited on the glass slides were examined microscopically, and the original, spherical particle diameter was estimated based on the previously-reported flattening coefficient.

The aerosol penetration through the diluter itself was quantified by comparing the deposition on a 4-inch (10.2 cm) diameter glass fiber filter paper installed downstream of the diluter and the deposition on fittings between the diluter and the filter paper against the total aerosol entering the diluter, which is the sum of the filter paper, fittings, and diluter deposition. The method for quantifying aerosol penetration with fluorescent tag is well established. See Kesavan and Doherty (2000) for an overview of the use of fluorescein, and Gupta and McFarland (2001) as an example of a similar aerosol penetration study. Note that the thermocouples that were installed within the diluter during the temperature and humidity tests were not utilized during the aerosol penetration tests, since these become deposition surfaces that are not expected in the actual diluter installation, and may cause a bias in the aerosol penetration results.

With the environmental chamber operating at the prescribed temperature and humidity condition, aerosol injection and sampling occurred for about 30 minutes; sufficient time to collect an adequate sample of aerosol on the filter and fittings. After each test, the test components for which the deposition would be quantified (diluter, filter, tubing) were washed with a pH-adjusted solvent (water and isopropyl alcohol) of known mass to remove and retain in solution the deposited aerosol and fluorescent dye. The mass of the solvent used to wash each component was measured using a platform scale, shown in Figure 3.6 (b). The fluorescence of aliquots (approximately 2ml) was measured with a Turner Trilogy (Sunnyvale, CA) fluorometer (Figure 3.6 (c)) in triplicate to quantify the deposited aerosol. The deposition on the test components was measured in units of raw fluorescence units per gram of wash solution.

Prior to the chamber tests, a set of preliminary tests were performed to establish the impact of temperature on fluorescence. For these tests, a 10 parts per billion (ppb) solution of fluorescein in water was subjected to elevated temperatures (170°F and 325°F) for 1 hour, and the fluorescence of that solution was compared with the fluorescence of a 10 ppb solution that was not subjected to elevated temperature. These tests demonstrated that the fluorescence of fluorescein is not degraded by this range of elevated temperatures. However, exposure to light causes some reduction in fluorescence. A cuvette of 10 ppb fluorescein solution, left near a window for two days, lost about 7% of its fluorescence as a result of light exposure. For any given test, the fluorescein exposure to light will be uniform for all test components, and will not result in any bias in the test results. However, to maintain a high fluorescence value for instrument detection, fluorescein solutions used in aerosol production were protected from light by storing it in amber bottles or covering transparent syringes in aluminum foil.

Due to the uncertainty regarding the actual installation of the sample conditioning equipment at the waste treatment plant, tests were performed with the diluter in both a horizontal and vertical orientation. Figure 3.7 shows the diluter mounted in a vertical orientation (the horizontal orientation was shown in Figure 3.2). The diluter with 28-inch overall length was installed vertically, while the 32-inch overall length diluter was too long to fit vertically, and was approximately 20° from vertical. As described above, at the conclusion of the aerosol sampling phase, the diluter, downstream fittings, and filter paper were washed to quantify the deposition. In the vertical orientation, the filter holder was still oriented horizontally, so the downstream fittings included a compression fitting on the diluter, an elbow, and the upstream portion of the filter holder. Figure 3.8 shows the filter paper and fittings, disassembled in preparation for washing. Whenever possible, fittings were assembled and washed as a single component to minimize the number of samples. For the horizontal orientation, the elbow is removed and the upstream end of the filter holder was connected directly to the compression fitting.

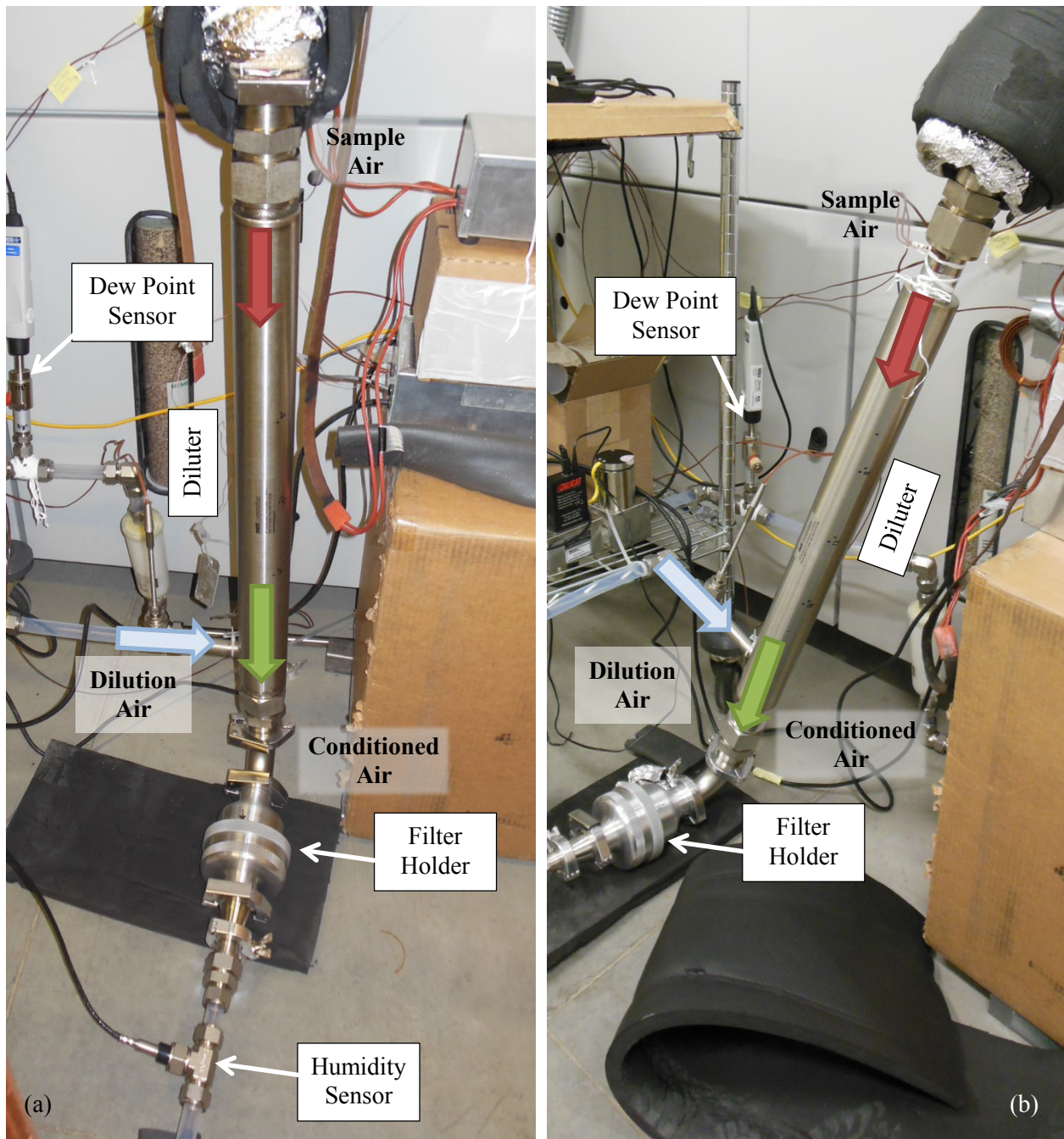

Figure 3.7. Sample Conditioner with 28-inch Overall Length (a) and 32-inch Overall Length (b) Installed in a Vertical Orientation. Light blue arrows represent the dilution air flow, the red arrow represents the hot sample air, and the green arrow represents the conditioned air.



Figure 3.8. Fittings and Filter Holder from Vertical Diluter Test Disassembled for Washing and Fluorescence Measurements

3.3 Quality Assurance

The PNNL QA program is based on the requirements defined in the U.S. Department of Energy Order 414.1D, *Quality Assurance*, and 10 CFR 830, *Energy/Nuclear Safety Management*, and Subpart A—*Quality Assurance Requirements* (a.k.a., the Quality Rule). PNNL has chosen to implement the following consensus standards in a graded approach:

- ASME NQA-1-2000, *Quality Assurance Requirements for Nuclear Facility Applications*, Part I, “Requirements for Quality Assurance Programs for Nuclear Facilities”.
- ASME NQA-1-2000, Part II, Subpart 2.7, *Quality Assurance Requirements for Computer Software for Nuclear Facility Applications*.
- ASME NQA-1-2000, Part IV, Subpart 4.2, *Graded Approach Application of Quality Assurance Requirements for Research and Development*.

The procedures necessary to implement the requirements are documented through PNNL’s “How Do I...?” (HDI), which is a system for managing the delivery of laboratory-level policies, requirements, and procedures.

The Waste Treatment Plant Support Program (WTPSP) implements an NQA-1-2000 QA program, using a graded approach presented in NQA-1-2000, Part IV, Subpart 4.2. The WTPSP Quality Assurance manual (QA-WTPSP-002) describes the technology life cycle stages under the WTPSP QA plan (QA-WTPSP-0001). The technology life cycle includes the progression of technology development, commercialization, and retirement in process phases of basic and applied research and development (R&D), engineering and production, and operation until process completion. The life cycle is characterized by flexible and informal QA activities in basic research, which becomes more structured and formalized through the applied R&D stages. The work described in this report has been completed under the QA Technology level of Development Work as the data will be used to apply for air discharge permits.

- **DEVELOPMENTAL WORK**—Development work consists of research tasks moving toward technology commercialization. These tasks still require a degree of flexibility, and there is still a degree of uncertainty that exists in many cases. The role of quality on development work is to make sure that adequate controls exist to support movement into commercialization.

WTPSP addresses internal verification and validation activities by conducting an Independent Technical Review of the final data report in accordance with WTPSP's procedure QA-WTPSP-601, "Document Preparation and Change." This review verifies that the reported results are traceable, that inferences and conclusions are soundly based, and the reported work satisfies the Test Plan objectives. Appendix F lists the reviewed test plan, test instructions, and calculation packages created to document and quality-assure the tests.

4.0 Sample Conditioner Testing Results

This section summarizes the results of the sample conditioner tests using the Mott porous tube diluter for the four Hanford Waste Treatment Plant stacks with elevated temperature and humidity conditions: LV-S2, LV-S3, HV-S3A, and HV-S3B. The primary, reportable results are the data and data calculations to document the temperature and humidity reduction and the aerosol penetration. For data sheets that include calculations, independent reviews were performed to verify the accuracy of the data transcription and calculations. Calculations were only necessary for the aerosol penetration data sheets. These calculations were performed using Microsoft Excel (Redmond, WA, 2010) and documented in Computational Computer Program (CCP) packages (see Appendix F) in accordance with WTPSP procedures. The final data sheets are included in Appendices A through C, and provide the detailed information about the test conditions and results. Tables summarizing the results of tests performed are presented in the subsections below. Additional data, which are designated as “For Information Only,” have not been produced under the full QA program, but provide valuable information about test conditions. These include time series data from the temperature and humidity sensors, MFC, and APS, along with any plots created with these data. Although these instruments have been calibrated, only the read-out on the screen has been quality-assured, and data collected in the internal memory or through external software has not been rigorously quality-assured under the Quality Program. Data that are for information only (FIO) are clearly indicated as such in both the data sheets and the summary tables included in this section.

4.1 LV-S3 Test Results

Table 4.1 lists the estimated dilution rates for the combinations of stack and ISA conditions (excerpted from Table 3.1). The sample conditioner tests representing the LV-S3 stack conditions used four of these pre-defined dilution rates. The four flow rates used in these tests are presented in normal font in Table 4.1, while the flow rates that were not used are in parentheses. The Maximum ISA for the Maximum Stack Condition was tested for the conservative dilution rate, which would be used if a fixed flow rate is used at the waste treatment plant to simplify practical operations. The individual results for the two test types are presented in the sub-sections below. A summary of these results were also briefly reported to Bechtel in a letter from R. Peterson, dated July 24, 2013 (WTP/RPP-MOA-PNNL-00738).

Table 4.1. Estimated Dilution Rates for LV-S3. Rates in parentheses were not used in tests.

Stack Condition	Temp (°F)	RH (%)	Norm ISA (60°F DB/-40°F DB)		Max ISA (80°F DB/-20°F DP)	
			Dil (scfm)	Cond (scfm)	Dil (scfm)	Cond (scfm)
Min	185	16.9	5.09	6.06	(5.19)	(6.16)
Norm	243	9.6	9.05	9.87	(9.26)	(10.07)
Max	282	5.6	9.76	10.52	9.97	10.72

4.1.1 LV-S3 Temperature and Humidity Tests

As described in Section 3, temperature and humidity tests were performed primarily to demonstrate the effectiveness of the sample conditioner and to document the temperature and humidity reduction with the sample conditioner. Appendix A.1 contains the data sheets from the LV-S3 temperature and humidity

reduction tests. These tests contained no calculations, so only the hand-written data sheets are necessary to document these tests. Note that, after these tests were already in progress, it was discovered that the thermocouples and thermocouple inputs for the environmental chamber had not been calibrated, as expected. Therefore, the dilution temperature on these data sheets is marked as collected using an uncalibrated thermocouple. However, after this testing was complete, the thermocouples were calibrated and found to be within tolerances.¹ Additionally, prior to the completion of these tests, the environmental chamber was calibrated, which included calibration of the thermocouple input ports.

These tests were performed with a 28-inch overall length diluter. All tests were performed with the diluter in the horizontal orientation, with the longitudinal axis of the diluter nominally parallel to the ground. Table 4.2 summarizes the results of the LV-S3 temperature and humidity tests. Rows with data in parentheses had condensation formation during the test, while the remaining tests successfully conditioned the sample without condensation. The test results in parentheses are considered invalid, and are not included in the final summary table (Table 5.1). In Table 4.2 and in other results tables, the dilution cases simulated during each test are defined by combining an ISA Condition and a Stack Condition as listed in Table 4.1. Each combination of ISA and stack condition results in an estimated dilution air flow rate. The Stack Cond and ISA Cond columns of Table 4.2 describe the combined ISA condition (Norm or Max, as listed in Table 2.2) and the stack condition (Min, Norm, or Max, as listed in Table 2.1) that were used to determine the dilution air rate for the test run. For example, row 1 of Table 4.2 lists the Stack Cond as “Min,” and the ISA Cond as “Norm,” meaning that the dilution rate used for this test was for the combination of the minimum stack condition and the normal ISA condition. The dilution air and conditioned air flow rates presented in Table 4.2 can be cross-referenced to the flow rates presented in Table 4.1 for the Stack condition and ISA condition combination presented in Table 4.2.

Detecting condensation internal to the system components is a challenge in these tests, and some basic experiential knowledge about condensation was gained through the course of testing activities. When significant amounts of condensation are formed, such as when the axial diluter was utilized, condensation is transported downstream to the filter paper, and saturates the paper. This causes a pressure signal in the MFC that alerts a condensation concern. However, small amounts of condensation, such as what occurred during some of the porous tube diluter tests, are more difficult to detect. Observing the interior surface of the diluter at the end of a test is typically ineffective in determining whether condensation had occurred during the test because small amounts of liquid readily evaporate with additional mixing with dry air. Alternately, observing the conditions of the diluted sample air may, hypothetically, provide an indication of condensation, but that does not appear to be the case practically. For example, compare the results of TH-8 in Table 4.2, which had condensation, and TH-10, which did not. The dilution rate was identical for these two tests, and the dilution air DP was very similar (-14 compared with -15°F). However, the conditioned air DP was also very similar (28 compared with 27°F). One might expect that the DP after condensation would be lower than the DP without condensation because liquid water is removed from the air when condensation occurs. However, small differences in DP, within the tolerance of the measurement, are difficult to attribute to condensation. As a result, three approaches were implemented during the temperature and humidity tests to detect the presence of condensation, as described below.

¹ Note that there are no adjustments to a thermocouple. If they are verified after the fact, the data is considered acceptable.

Table 4.2. Summary of Temperature and Humidity Reduction Tests for LV-S3 Conditions

Dilution Case ^a		Run No. ^{b,c}	Chamber		Dilution Air			Conditioned Air				
Stack Cond	ISA Cond		DB (°F)	RH (%)	Flow (scfm)	DB (°F) ^d	DP (°F)	Flow (scfm)	DB (°F)	DP (°F)		
Min	Norm	TH-4	185	16.9	5.09	77	-26	6.06	84	52		
Norm	Norm	TH-1	243	9.6	9.05	77	-15	9.87	83	46		
		TH-12				79	-15		85	28		
Max	Max	(TH-3)			9.97	(85)	(29)	(85)	(43)			
		(TH-6)				(80)	(10)	(83)	(40)			
		(TH-7)				(80)	(-13)	(82)	(34)			
		(TH-8)				(80)	(-14)	(82)	(28)			
		TH-9				75	-20	82	23			
		TH-10				76	-15	81	27			
Max	Norm	(TH-5)			282	5.6	9.76	(85)	(11)	10.52	(89)	(47)
		TH-11					77	5	86		43	
Max	Max	TH-2					9.97	82	-21	10.72	85	36

- a. Dilution cases are defined by the combination of stack and ISA conditions from Table 4.1.
- b. TH-3, TH-5 through TH-8 (in parenthesis) had signs of condensation
- c. Initial tests (TH-1 through TH-8) used just one heat tape, which covered only the fitting upstream of the diluter. TH-9 through TH-12 used two heat tapes; the second heat tape covered the upstream end of the diluter, along with a few inches of the upstream end of the diluter housing.
- d. Dilution temperatures are FIO. Measured with an un-calibrated thermocouple that was later calibrated and found to be within tolerance.

First, a thermocouple was placed on the interior surface of the solid wall of the diluter inlet, as close as possible to the weld seam between the solid and porous stainless steel. As described in Section 3, this is the most likely location for condensation to form. By observing whether the temperature near the weld seam is near the DP temperature of the chamber/stack sample, an indication of potential condensation is obtained. However, the placement of the thermocouple tip is difficult, and small changes in position can result in large differences in temperature. As a result, a high temperature does not preclude condensation formation due to position errors, while a low temperature is more likely to confirm condensation formation if the thermocouple is affixed upstream of the weld seam. Slight movement of the thermocouple toward the downstream end of the weld seam would result in measurements of the dilution air temperature, and condensation is not expected where the two air streams are mixing. The position of the thermocouple was observed at the conclusion of each test, but the act of dis-assembling equipment can also cause shifts in the thermocouple position. It was often difficult to have absolute confidence in the thermocouple position in each test.

Secondly, water indicator dots manufactured by 3M (Saint Paul, MN) were affixed around the circumference of the solid inlet tube, again, near the weld seam between the solid and porous tubes. These dots remain white in the absence of water; however, when water is in contact with the dot, the dot turns red, and the color change is irreversible. The utility of these dots is that, if at any point during the test, a small amount of condensation is formed, and then evaporated as the sample air is mixed with the dilution air, that presence of water is “recorded” by the water indicator dot. The drawbacks of these dots are that spurious condensation could form at other locations not covered by the dot, and that condensation would not be observed. This is mitigated by placing at least four dots around the circumference of the tube, with one of these dots at the bottom of the tube, where condensation is likely to pool. Another drawback is that these dots are recommended for temperatures up to 121°C (250°F) for time scales from minutes to hours. In our experience, at the highest test temperatures, the dye in the water indicator dot becomes fixed, and the dots do not change color when water contacts it. It is likely that this occurred at temperatures above 250°F, as the technical data sheet for this product suggests, but a rigorous test of the impact of temperature was not conducted.

Finally, water soluble markers were used to mark the inlet end of the diluter. We observed that these markings are readily removed by liquid water, and would allow greater coverage than the water indicator dots. Figure 4.1 shows the inlet and outlet of the diluter with the water indicator dots and water soluble markings. The left panel shows two water indicator dots that have been in contact with water, and are pink. Although difficult to discern, there is a small puddle of water visible in the photograph, and the lower water indicator dot is submerged in that small puddle. Water indicator dots located on the downstream end of the diluter always remained white, since this diluter does not result in condensed water being transported to the downstream end of the diluter.

Initially, testing was performed with heat tape and insulation applied only on the flange to the chamber, the transport line, and the fitting that was upstream of the diluter. Figure 3.2 and Figure 3.7 are examples that show the extent of the first heat tape coverage. The heat tape was set to match the chamber temperature, so that the air entering the diluter would be matched as closely as possible to the chamber conditions. As noted in Table 4.2, several of the tests performed with the LV-S3 conditions resulted in condensation. This condensation was mostly likely formed at the diluter inlet, through cooling of the inlet tube due to heat transfer from the cool dilution air in the diluter housing. As a result, a second heat tape was applied for subsequent tests to ensure that the inlet of the diluter remained above the DP of the chamber air. This heat tape was applied from the end of the first heat tape at the upstream fitting through the first few inches of the upstream end of the diluter housing as shown (without the insulation) in Figure 4.2. Tests with both heat tapes in place avoided condensation.

The conditioned air temperatures for LV-S3 tests summarized in Table 4.2 are comparable to the estimated temperatures listed in Table 3.1. Since the DP of the dilution air was not simulated in these tests, the DPs listed in Table 3.1 are not a relevant comparison for these results. However, the DPs for these tests are universally lower than 60°F, with values ranging from 23°F to 52°F. Overall, these tests demonstrated that, with the appropriate heat tape in place, the porous tube diluter is effective in conditioning the stack exhaust samples for the expected LV-S3 conditions.

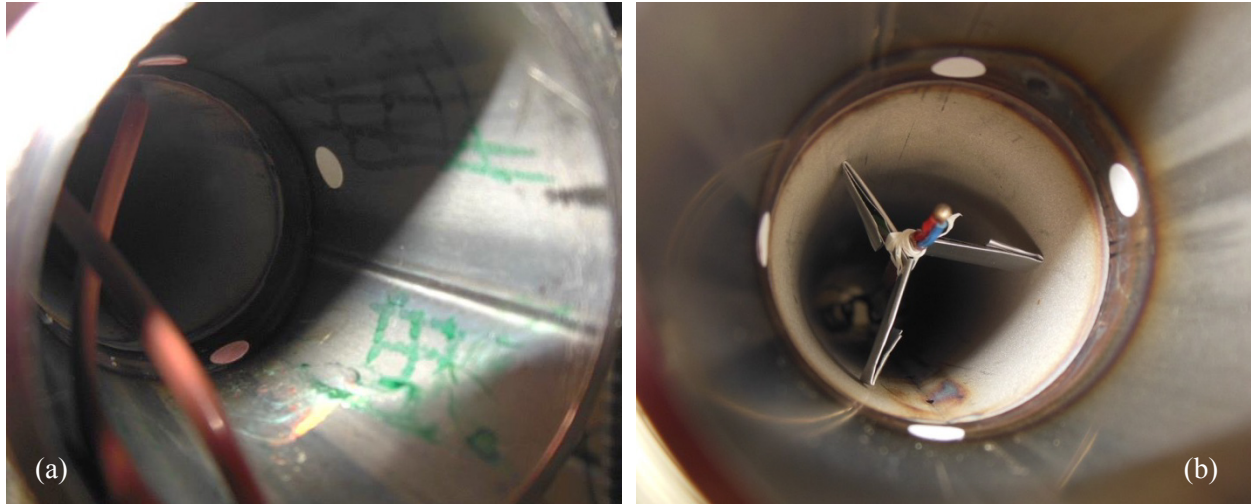

Figure 4.1. Water Indicator Dots on the Upstream End (a) and Downstream End (b) of the Diluter. (a) shows a small water puddle and pink water indicator dots (top and bottom of tube) as well as the green water soluble markings.

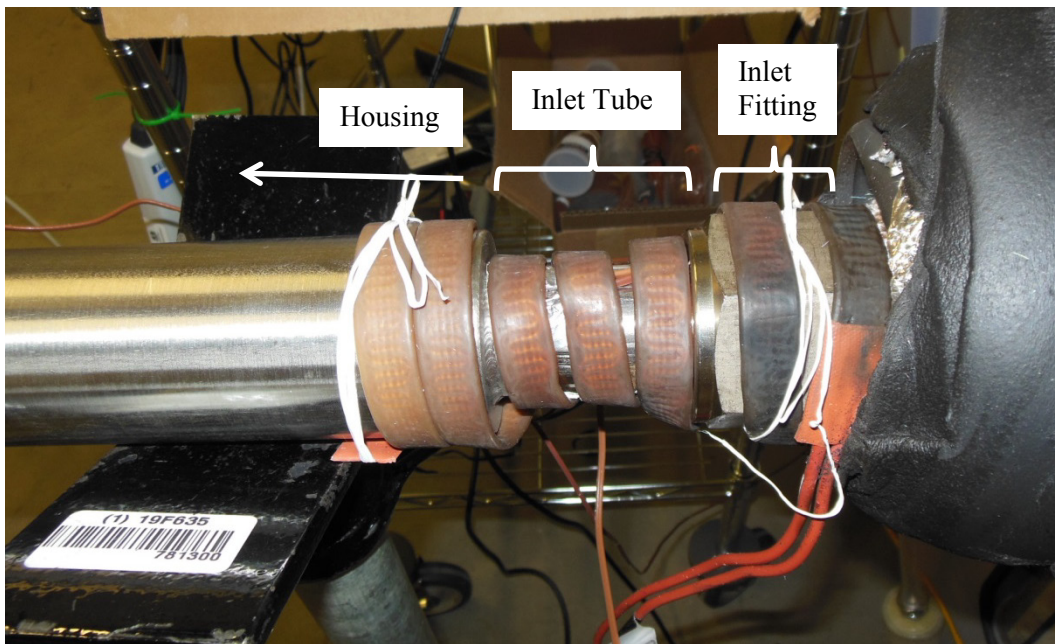

Figure 4.2. Heat Tape Wrapped around Inlet Tube and Upstream End of Housing (diluter with 32-inch overall length). During tests, the heat tape was covered in insulation.

4.1.2 LV-S3 Temperature, Humidity, and Aerosol Tests

Aerosol penetration tests were performed at both near-ambient room conditions and normal LV-S3 stack conditions, in both a vertical and horizontal orientation. Table 4.3 lists the results for the aerosol penetration tests performed for LV-S3 dilution conditions. In general, the results for these tests show that there is high aerosol penetration with this diluter. The completed data sheets from these tests are available in Appendix A.2.

Table 4.3. Summary of Aerosol Penetration Tests for the LV-S3 Conditions

Dilution Case ^a		Run No.	Chamber		Dilution Air			Conditioned Air			Aerosol Penetration	AD (µm) ^c	H/V ^d
Stack Cond	ISA Cond		DB (°F)	RH (%)	Flow (scfm)	DB (°F)	DP (°F)	Flow (scfm)	DB (°F)	DP (°F)			
Norm	Norm	AP-1	75	22	9.05	92	38	9.87	87	25	99%	9.6-9.7	H
Norm	Max	AP-2	75	40	9.76	84	22	10.34 ^b	80	13	98%	9.5-9.4	
Norm	Norm	AP-3	243	9.6	9.05	81	7	9.87	95	51	99%	9.6-9.4	H
Norm	Max	AP-4	243	9.6	9.76	87	8	10.52	99	47	99%	9.5-9.3	H
		AP-5				89	16		100	49	99%	10.0-9.7	V
		AP-6				87	-6		101	47	99%	9.3-9.1	V

- a. Dilution cases are defined by the combination of stack and ISA conditions from Table 4.1.
- b. AP-2 conditioned air flow was incorrectly set at 10.34 scfm instead of 10.52 scfm, so the sample from the chamber is low.
- c. Aerodynamic diameters from the un-calibrated APS are FIO.
- d. Diluter orientation: H=Horizontal, V=Vertical

Two room temperature tests (AP-1 and AP-2) were performed to evaluate whether there is a relationship between the aerosol penetration result and the chamber temperature. Recall that the test method involves injecting droplets of oleic acid and fluorescein into the chamber and sampling it through a shrouded probe with a transport line that passes through the wall of the chamber to the dilution system. Therefore, if there is temperature-related degradation or shrinking of the droplets, comparing room temperature tests with elevated temperature tests would, presumably, indicate these effects. The two room temperature tests (AP-1 and AP-2) had penetration values of 98 and 99%, which is the same as the penetration values for the four LV-S3 normal temperature condition tests (AP-3 through AP-6), which were all 99%. Therefore, it appears that there is no impact of temperature on the aerosol or aerosol penetration. Note that the differences in the relative humidity between the two room temperature tests was not strategic in any way, and is not expected to have impacted the small difference in aerosol penetration rates.

The four tests performed at the LV-S3 normal temperature condition were performed for two different dilution rates and for two different diluter orientations. Again, since all tests resulted in 99% aerosol penetration, it appears that there is no effect to the aerosol penetration based on diluter orientation or the relatively small difference in dilution rate.

4.2 HV-S3A and HV-S3B Test Results

Table 4.4 lists the HV-S3A & B dilution rates for the combinations of stack and ISA conditions (excerpted from Table 3.1.) The sample conditioner tests representing the HV-S3A & B stack conditions used five of these pre-defined dilution rates as well as one additional, conservatively high dilution rate. The flow rates used in these tests are presented in normal font in Table 4.4, while the flow rate that was not tested (Maximum ISA for Normal Stack Condition) is shown in parentheses. The Maximum ISA for the Maximum Stack Condition was tested for the conservative dilution rate, which would be used if a

fixed flow rate is implemented at the waste treatment plant to simplify practical operations. The individual results for the temperature and humidity tests and the temperature, humidity, and aerosol tests are presented in sub-sections below.

Table 4.4. Estimated Dilution Rates for HV-S3A and HV-S3B. Rates in parentheses were not used in tests.

Stack Condition	Temp (°F)	RH (%)	Norm ISA (60°F DB/-40°F DB)		Max ISA (80°F DB/-20°F DP)	
			Dil (scfm)	Cond (scfm)	Dil (scfm)	Cond (scfm)
Min	261	2.3	2.39	3.31	3.61	4.53
Norm	313	1.7	4.07	4.88	(4.63)	(5.44)
Max	365	1.5	7.42	8.13	7.63	8.34

4.2.1 HV-S3A and HV-S3B Temperature and Humidity Tests

The HV-S3A and HV-S3B temperature and humidity tests were performed to demonstrate the effectiveness of the sample conditioner and to document the temperature and humidity reduction with the sample conditioner. Appendix B.1 contains the data sheets from the HV-S3 temperature and humidity reduction tests. These tests contained no calculations, so only the hand-written data sheets are necessary to document these tests. For these tests, both the thermocouples and thermocouple inputs were calibrated.

The HV-S3 temperature and humidity tests were performed with both the 28-and32-inch overall length diluters. During LV-S3 testing, we learned that applying heat tape to the inlet tube and the first few inches of the housing prevented condensation. However, the short length of the inlet tube made it difficult to get good contact between the heat tape and the tube at the point nearest to the diluter housing (see Figure 3.2). As a result, a similar diluter with identical porous tube length, but with a longer inlet and outlet tube was obtained. This allowed some space between the compression fitting and the filter housing to allow for improved heat tape contact (see Figure 4.2). Until the new 32-inch diluter was delivered, tests were performed with the previous 28-inch diluter. All tests were performed with the diluter in the horizontal orientation (with the longitudinal axis of the diluter nominally parallel to the ground). Table 4.5 summarizes the results of the HV-S3 temperature and humidity tests. Because of the improved heat tape configuration, none of the tests resulted in condensation.

Table 4.5. Summary of Temperature and Humidity Reduction Tests for the HV-S3 Conditions

Dilution Case ^a		Run No.	Chamber		Dilution Air			Conditioned Air		
Stack Cond	ISA Cond		DB (°F)	RH (%)	Flow (scfm)	DB (°F)	DP (°F)	Flow (scfm)	DB (°F)	DP (°F)
Norm	Min	TH-1	261	2.3	2.39	76	-4	3.31	90	71
Norm	Norm	TH-2	313	1.7	4.07	79	-17	4.88	93	63
		TH-8			4.17 ^d	82	-17		94	60
Max	Max	TH-3			7.63	84	-7	8.34	92	45
		TH-10 ^b	80	2		88	44			
Norm	Max	TH-4	365	0.8 ^c	7.42	75	4	8.13	86	24
		TH-7		1.6 ^c		81	-17		91	50
Max	Max	TH-5		1.2 ^c	7.63	79	6	8.34	89	46
>Max	>Max	TH-6	1.2 ^c	8.50	76	10	9.20	86	44	
		TH-9 ^b			77	-4		85	53	

- Dilution cases are defined by the combination of stack and ISA conditions from Table 4.1.
- Most tests were performed with a diluter with 28-inch overall length. The final two tests (TH-9 and TH-10), however, used a diluter that was 32-inches in overall length (more room for fittings).
- During these tests, humidity control on the environmental chamber was disabled for temperatures above ~330°F. As a result, the target humidity of 1.5% was not achieved for these tests.
- Dilution flow rate for TH-8 was incorrectly set 0.1 scfm higher than it should have been.

The HV-S3 temperature and humidity test results show that, even with relatively high dilution air temperatures and DPs, successful sample conditioning occurred. Although several tests had DP temperatures at or greater than 60°F, the room where testing was performed was always hotter than the conditioned air DP temperature, so condensation was not formed during any of these tests. These results show that dilution air DP temperatures can be quite a bit higher than the maximum ISA conditions, and with conservative dilution rates, the conditioned air DP is often still acceptable.

4.2.2 HV-S3A and HV-S3B Temperature, Humidity, and Aerosol Tests

Aerosol penetration tests were performed at room temperature as well as at the HV-S3 minimum, normal, and maximum temperature conditions. All tests used the diluter with 32-inch overall length, and tests were performed with the diluter in both a horizontal and nominally vertical orientation. The 32-inch diluter, with fittings, was longer than the vertical space between the chamber outlet and the floor. As a result, the vertical orientation tests were performed with the diluter approximately 20° from vertical (see Figure 3.7). LV-S3 tests indicated that there was no impact to the aerosol penetration results due to diluter orientation, and these HV-S3 results are also similar for both diluter orientations. A summary of the HV-S3 aerosol penetration test results is presented in Table 4.6, and the completed data sheets from these tests are available in Appendix B.2.

Note that the data sheets include both the measured AD from the calibrated APS as well as the calculated AD based on the VOAG operating conditions and the aerosol solution. Since the APS measures the AD directly, the AD from this instrument is more accurate and reliable. The calculated particle size is listed as an indication for potential troubleshooting purposes. Although the calculated particle size should include all relevant factors that influence the final particle size, there are large differences between the measured and calculated aerosol size, which indicates that there are other factors that are not taken into account in these calculations. The calculated and measured aerosol sizes for both the LV-S3 and HV-S3 tests are tabulated within Appendix D.

There were several challenges in aerosol production and sampling during the course of these HV-S3 tests. Note that rows with text in parentheses in Table 4.6 represent tests with either poor aerosol production or low fluorescence particle counts. As a result, some consideration should be taken in interpreting these data, and these test results are not included in the final summary table (Table 5.2). AP-1 had low fluorescence values in the first wash, which indicates that insufficient particle deposition occurred on the final filter and the other internal surfaces. When sufficient deposition is measured, between 40 and 100 RFU/g (raw fluorescence units/gram of wash solution) was observed on at least one of the test components. However, AP-1 fluorescence measurements were less than 1 RFU/g, which means that there are very few particles included in the measurement, and consequently reduced confidence in the results of this test. AP-2, AP-10, and AP-12 also had less than 1 RFU/g for all elements in the first wash. These poor particle collection results were attributable to a misalignment of the flexible duct used to direct particles to the shrouded probe. For example, during AP-10, the flexible duct had fallen away from the aerosol injection probe, so most of the particles were directed away from the shrouded probe. In addition, we found that there was a particular location within the center of the environmental chamber fan that, if the flex duct opening was positioned over it, the air within the duct flowed from the shrouded probe toward the fan, rather than directing the aerosol toward the shrouded probe from the fan. Correcting these two flexible duct positions improved the aerosol collection for the test.

Table 4.6. Summary of Aerosol Penetration Tests for the HV-S3 Conditions

Dilution Case ^a		Run No.	Chamber		Dilution Air			Conditioned Air			Aerosol Penetration	AD (μm)	H/V ^g				
Stack Cond	ISA Cond		DB. (°F)	RH (%)	Flow (scfm)	DB (°F)	DP (°F)	Flow (scfm)	DB (°F)	DP (°F)							
Norm	Norm	(AP-1)	73.5	50	4.07	(77)	(3)	4.88	(76)	(16)	(87%) ^b	(10.2-10.2)	H				
		(AP-10)	73.5	35	4.07	(81)	(1)	4.88	(78)	(12)	(84%) ^b	(9.31-9.02)	V				
		AP-11				80	0		78	4	95% ^c	10.7-11.0					
		(AP-12)				(76)	(-2)		(76)	(10)	(82%) ^b	(10.8-10.3)					
		AP-13				79	3		78	11	98%	12.5-11.9					
Norm	Max	(AP-2)	73.5	50	7.42	(84)	(25)	8.13	(82)	(21)	(74%) ^b	(10.2-9.66)		H			
		AP-14	35	73		-9	74		-2	98%	11.0-9.89	V					
Max	Min	(AP-15)	261	2.3	3.61	(68)	(-25)	4.53	(99)	(57)	(95%) ^d	(14.5-10.4)	V				
		(AP-16)				(72)	(-24)		(105)	(57)	(96%) ^d	(14.0-13.2)					
Norm	Norm	AP-3	313	1.7	4.07	79	-22	4.88	112	70	99%	9.38-9.53	H				
		AP-5				74	-10		107	72	99%	9.31-8.96	V				
		AP-7				73	3		105	72	99%	8.99-8.45					
Norm	Max	AP-4				365	0.8 ^e		7.42	80	-16	8.13	99	48	99%	9.20-9.33	H
		AP-6								79	0		101	55	99%	9.36-8.95	V
Norm	Max	AP-8	365	1.5	7.42			78		-3	8.13		101	46	99%	11.0-10.6	V
Max	Max	AP-9						7.63		76			0	8.34	101	69	

- Dilution cases are defined by the combination of stack and ISA conditions from Table 4.1.
- AP-1, AP-2, AP-10, and AP-12 had unusually low particle counts
- AP-11 had an unusual deposition distribution, where the fittings had twice the deposition of the filter, and moderate particle counts.
- AP-15 and AP-16 had aerosol production challenges
- During AP-8, humidity control on the environmental chamber was disabled for temperatures above ~330°F. As a result, the target humidity of 1.5% was not achieved. This limitation was discovered and removed for AP-9.
- The APS was not available during AP-9, so OPC measurements were used to estimate the mean AD. The OPC had coarse size bins, so it is expected that the size is 3-4 microns larger than APS (based on APS-OPC comparison during AP-10 and AP-11).
- Diluter Orientation: H=Horizontal, V=Vertical. Diluter with 32-inch overall length was used, which is longer than the distance to the floor, so when these tests were performed vertically, the diluter was actually about 20° from vertical.

Two tests to simulate the HV-S3 minimum stack conditions, AP-15 and AP-16, had aerosol production challenges. During AP-15, the aerosol jet production from the vibrating orifice aerosol generator quit unexpectedly. The jet was re-established quickly (within 1 minute); however, the particle size distribution was not as monodisperse and the mean AD was not as large as we had preferred for this

test. To evaluate the impact of particle size on the deposition result, this test began with aerosol production at 14.5 μm . However, by the end of the test, the mean AD was closer to 10.5 μm . In an attempt to perform a test with more reliable particle production, the AP-15 conditions were repeated with AP-16. Unfortunately, this test also had a broader particle size distribution than preferred, although the mean particle size was somewhat more consistent. The particle size mean was 14.0 μm at the start of the test, and 13.2 μm at the end of the test. Both the AP-15 and AP-16 aerosol penetration results were around 95%, which is somewhat lower than the majority of the tests, which were 98 to 99%. Therefore, there is an indication that larger particle sizes result in slightly higher deposition within the diluter.

AP-11, which had a relatively low aerosol penetration of 95%, had two somewhat unusual qualities in its penetration data. First, the majority of tests had the highest aerosol deposition on the filter paper, and a smaller amount on the fittings. AP-11, however, had twice the deposition on the fittings compared with the filter paper. In addition, while most filter aerosol deposition quantities were from 40 to 100 RFU/g, the aerosol deposition on the fittings during AP-11 was only 10.4 RFU/g. These two qualities make this test unusual, and no specific cause for this has been determined, so there is no reason to discount this result, except in that the fluorescence signal was perhaps marginal compared with other tests. For the remaining tests that had both good aerosol production and good aerosol collection, aerosol penetration values were similar to the results from LV-S3, typically between 98 and 99%. These high penetration values were observed for both diluter orientations, and there appears to be no impact of dilution flow rate (within the range tested) on the aerosol penetration.

During HV-S3 aerosol testing, the use of glass slides with oleophobic coating was explored to measure the particle size within the environmental chamber. Although the APS or OPC was used to measure the particle size injected into the chamber, there was some concern that the particles shrink within the chamber due to the high temperatures. Figure 4.3 shows an image of a portion of a glass slide that was placed near the floor of the chamber during AP-7. This shows two droplets that appear to be fluorescein-dyed oleic acid. The scale on the image is not calibrated, and is FIO. However, the deposited (and flattened) particles appear to be between 8.5 and 9.0 μm in diameter (assuming that part of the halo around the yellow portion visible in the image is part of the particle). The flattening factor for oleic acid on this coating has not been experimentally determined; however, the previously-reported flattening factor of 1.34 from Olan-Figueroa (1982) is expected to be a good approximation for this coating. If the 1.34 flattening factor is assumed, the particles deposited in Figure 4.3 were 6.3 to 6.7 μm in diameter as a spherical particle. The measurement from the APS during AP-7 was nominally from 8.5 to 9.0 μm in AD, which corresponds to a physical diameter (PD) of 9.0 to 9.5 μm . (The physical diameter is simply the AD divided by the square-root of the aerosol density, which is 0.8931 g/cm^3 .) Under these assumptions, the oleic acid particle diameter shrank by about 2.7 microns, or 30%, within the chamber. A summary of the particle sizes from the APS and from the glass slide is presented in Table 4.7. Note that the glass slides were placed in the chamber at the start of the test, and retrieved after the end of the test, when the chamber interior had cooled. Therefore, the particles on these slides are expected to have experienced the maximum particle size reduction. The slides were within the chamber for about 60 minutes, whereas the particles involved in the tests were transported from the injection point to the collection point in about 7 seconds. The particle size reduction for shorter timeframes has not been determined.

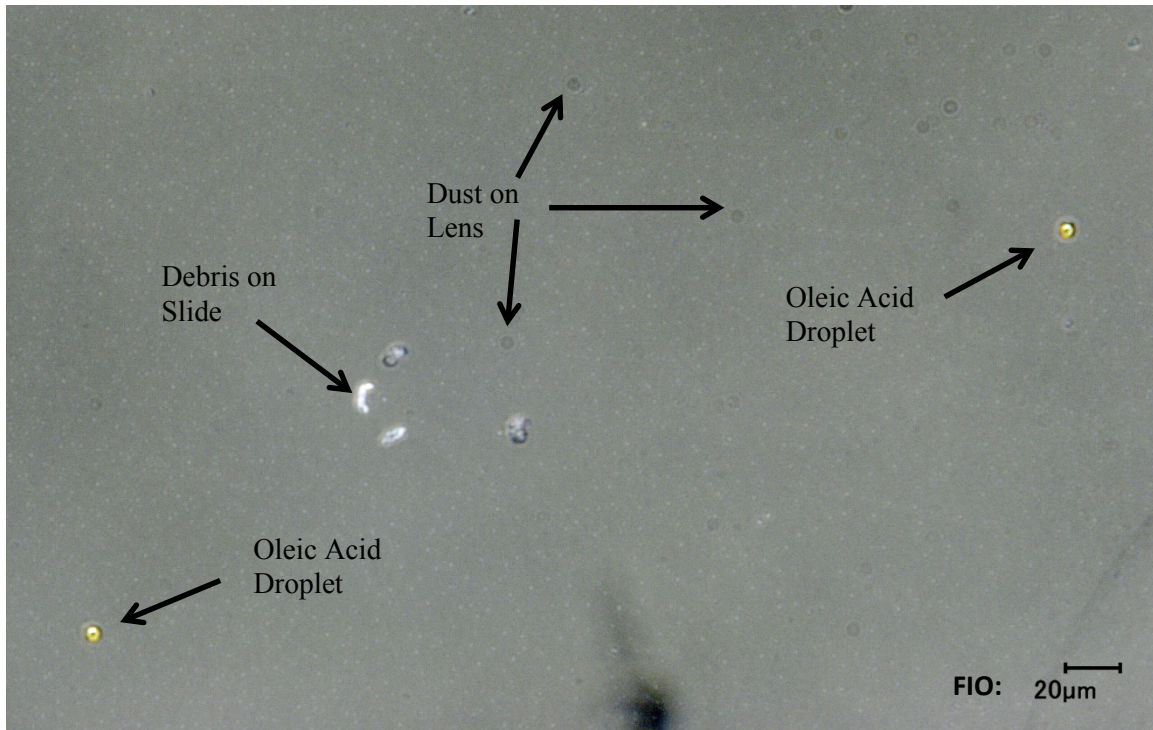

Figure 4.3. Light Microscope Image (800x) of Oleic Acid Droplets Collected on a Glass Slide with Oleophobic Coating During AP-7. Scale is FIO.

Table 4.7. HV-S3 AP-7 Particle Sizes from APS, Glass Slide

APS, Prior to Injection		Glass Slide in Chamber		
Measured AD (μm)	Calculated PD (μm)	Flattened (μm , FIO)	Estimated AD (μm , FIO)	Calculated PD (μm , FIO)
8.5 – 9.0	9.0 – 9.5	8.5 – 9.0	6.0 – 6.3	6.3 – 6.7

4.3 LV-S2 Test Results

The limited sample conditioner tests for the LV-S2 stack conditions were performed under two pre-defined dilution rates. Table 4.8 lists the estimated LV-S2 dilution rates for the combinations of stack and ISA conditions (excerpted from Table 3.1). Of these values, the flow rates tested were the two non-parenthesized rates.

Table 4.8. Estimated Dilution Rates for LV-S2. Rates in parentheses were not used in tests.

Stack Condition	Temp (°F)	RH (%)	Norm ISA (60°F DB/-40°F DB)		Max ISA (80°F DB/-20°F DP)	
			Dil (scfm)	Cond (scfm)	Dil (scfm)	Cond (scfm)
Norm	130	10	0.48	1.65	(0.79)	(1.96)
Max	210	6	(2.48)	(3.46)	5.08	6.09

Three LV-S2 temperature and humidity tests were performed to demonstrate the effectiveness of the sample conditioner and to document the temperature and humidity reduction with the sample conditioner. Appendix C contains the data sheets from the LV-S2 temperature and humidity reduction tests. These tests contained no calculations, so only the hand-written data sheets are necessary to document these tests. For these tests (unlike the LV-S3 tests), both the thermocouples and thermocouple inputs were calibrated.

The LV-S2 temperature and humidity tests were performed with the diluter with 28-inch overall length, and all three tests were performed with the diluter in a horizontal orientation. The results of the three LV-S2 tests are summarized in Table 4.9. These test results are similar to the HV-S3 test results in that, even with relatively high dilution air temperatures and DPs, successful sample conditioning occurred. No aerosol testing was performed under the LV-S2 conditions.

Table 4.9. Summary of Temperature and Humidity Reduction Tests for the LV-S2 Conditions

Dilution Case ^a		Run No.	Chamber		Dilution Air			Conditioned Air		
Stack Cond	ISA Cond		DB (°F)	RH (%)	Flow (scfm)	DB (°F)	DP (°F)	Flow (scfm)	DB (°F)	DP (°F)
Norm	Norm	TH-1	130	10.0	0.48	83	-1	1.65	87	47
Max	Max	TH-2			5.08	84	-7	6.09	86	13
Max	Max	TH-3	210	6.0	5.08	82	0	6.09	90	37

a. Dilution cases are defined by the combination of stack and ISA conditions from Table 4.1.

5.0 Conclusions

Two types of sample dilution equipment were evaluated in this project. The first, an axial diluter, resulted in the consistent formation of condensation, which can “scrub” aerosol from the sample stream and damage the sample filter. In subsequent tests the axial diluter was replaced with a porous tube diluter. Only limited tests were performed with the axial diluter, while the complete suite of tests was performed with the porous tube diluter.

Tests to evaluate the Mott porous tube diluter effectiveness at reducing the air temperature and dew point and to transport the sampled aerosol particles were performed under simulated LV-S3, HV-S3A, HV-S3B, and LV-S2 exhaust temperature and humidity conditions. A CAM will be installed on the LV-S3, HV-S3A, and HV-S3B stacks, and it has a temperature limit of 120°F. All four stacks will be equipped with a record sampler, which has a temperature limit of 150°F (65°C). At the WTP, the room air where stack monitoring occurs is expected to exceed 60°F. Dilution flow rates for these tests were estimated to either meet the target of DP less than 60°F or DB less than 120°F. The dilution air conditions were not controlled for these tests, but individual cases often met or exceeded these criteria.

5.1 Temperature and Humidity Test Results

The results of the temperature and humidity tests are summarized in Table 5.1. Note that only the valid data results where condensation was not formed are included in this table. Specifically, the data in parentheses from Table 4.2 are not included.

The outcomes of the temperature and humidity tests were

- the estimated dilution rates were a good starting point for conditioning the exhaust air,
- although the dilution air DP was not controlled or simulated in these tests, the resulting conditioned air DP was sufficient for preventing condensation in room air temperatures,
- the identification of condensation during sample conditioning is a significant challenge, and only large quantities of condensed moisture are readily detected, and
- the porous tube diluter has one potential cold spot on the upstream end of the diluter near the interface of the inlet tube and the diluter housing that should be heated to prevent condensation.

With the addition of a heat tape applied to the upstream end of the housing, the porous tube diluter is an effective sample conditioner that avoids internal condensation. A diluter with a 1.5-inch diameter inlet tube should be at least 4 inches in length to allow sufficient space for heating between compression fittings and the diluter housing (see Figure 4.2). This allows good contact between heat tape and the inlet tube and diluter housing to prevent condensation. An inlet tube of 2 inches in length is insufficient for heat tape application if a compression fitting is used.

5.2 Temperature, Humidity, and Aerosol Test Results

The results of the temperature, humidity, and aerosol tests are summarized in Table 5.2. Only valid data results are included here; specifically, the data in parentheses from Table 4.6 are not included. Tests

were performed for the LV-S3, HV-S3A, and HV-S3B conditions. The LV-S2 stack was not tested due to the expectation that sample conditioning may not be installed on this stack, and if a conditioning system is installed, results from other tests guide the LV-S2 installation. The criterion for transport system aerosol penetration is given in American National Standards Institute/Health Physical Society (ANSI/HPS) N13.1-1999, *Sampling and Monitoring Releases of Airborne Radioactive Substances from the Stack and Ducts of Nuclear Facilities*. This standard states that 50% of the 10 μm AD particles in the stack free stream must be delivered to the sample collector. In other words, depositional loss of particles should be limited to 50% in the sampling, transport, and conditioning systems. Based on preliminary estimates of the aerosol deposition along the LV-S3 transport lines using the DEPO 2001a code, the sample conditioner should have an 80% penetration or higher to ensure that the total transport system complies with the 50% penetration criterion. The aerosol penetration during these tests was greater than or equal to 95%, with most values equal to 98% or higher. The aerosol penetration was independent of

- dilution rate,
- diluter orientation,
- sample air temperature and humidity conditions, and
- aerosol size (within the tested range of 8.5 to 12.8 microns).

The high aerosol penetration rate under all test conditions was anticipated because the dilution air passes through the porous walls and essentially prevents the sample air from contacting the porous walls. Without contact with the walls, the aerosol deposition on those walls is understandably limited. We anticipate that, as long as the dilution rate is a positive value, and particularly if it is greater than or equal to the sample rate, penetration values should remain high. The primary location for aerosol deposition in this type of diluter is expected to be in the solid inlet and outlet tubes of the diluter.

Table 5.1. Summary of Temperature and Humidity (TH) Test Results

Dilution Case ^a		Run No.	Chamber			Dilution Air			Conditioned Air		
Stack Cond	ISA Cond		Stack	DB (°F)	%RH	Flow (scfm)	DB (°F)	DP (°F)	Flow (scfm)	DB (°F)	DP (°F)
Norm	Norm	TH-1	LV-S2	130	10.0	0.48	83	-1	1.65	87	47
Max	Max	TH-2				5.08	84	-7	6.09	86	13
Min	Norm	TH-4	LV-S3	185	16.9	5.09	77 ^b	-26	6.06	84	52
Max	Max	TH-3	LV-S2	210	6.0	5.08	82	0	6.09	90	37
Norm	Norm	TH-1	LV-S3	243	9.6	9.05	77 ^b	-15	9.87	83	46
		TH-12					79 ^b	-15		85	28
Max	Max	TH-9				75 ^b	-20	10.72	82	23	
		TH-10				76 ^b	-15		81	27	
Min	Norm	TH-1	HV-S3	261	2.3	2.39	76	-4	3.31	90	71
Max	Norm	TH-11	LV-S3	282	5.6	9.76	77 ^b	5	10.52	86	43
Max	Max	TH-2				9.97	82 ^b	-21	10.72	85	36
Norm	Norm	TH-2	HV-S3	313	1.7	4.07	79	-17	4.88	93	63
		TH-8				4.17 ^c	82	-17		94	60
Max	Max	TH-3				84	-7	8.34	92	45	
		TH-10 ^d				7.63	80		2	88	44
Max	Norm	TH-4	HV-S3	365	0.8 ^e	7.42	75	4	8.13	86	24
		TH-7			1.6 ^e	81	-17	91		50	
Max	Max	TH-5	HV-S3	365	1.2 ^e	7.63	79	6	8.34	89	46
>Max	>Max	TH-6	HV-S3	365	1.2 ^e	8.50	76	10	9.20	86	44
		TH-9 ^d					77	-4		85	53

- Dilution cases are defined by the combination of stack and ISA conditions from Table 4.1.
- LV-S3 dilution temperatures are FIO. Measured with an un-calibrated thermocouple that was later calibrated and found to be within tolerance.
- Dilution flow rate for HV-S3 TH-8 was incorrectly set 0.1 scfm higher than it should have been.
- HV-S3 TH-9 and TH-10 used a diluter with 32-inch overall length. All other tests used a diluter with 28-inch overall length.
- During these tests, humidity control for the environmental chamber was erroneously limited, so the target humidity of 1.5% was not achieved.

Table 5.2. Summary of Temperature, Humidity, and Aerosol (AP) Test Results

Dilution Case ^a		Run No.	Chamber			Dilution Air Flow (scfm)	Cond. Air Flow (scfm)	AD (μm)	Aerosol Penetration	H/V ^c
Stack Cond	ISA Cond		Stack	DB (°F)	RH (%)					
Norm	Norm	AP-11	HV-S3	73.5	35	4.07	4.88	10.7-11.0	95%	V
		AP-13						12.5-11.9	98%	
Max	Norm	AP-14				7.42	8.13	11.0-9.9	98%	V
Norm	Norm	AP-1	LV-S3	75	22	9.05	9.87	9.6-9.7 ^b	99%	H
Max	Norm	AP-2	LV-S3	75	40	9.76	10.34 ^d	9.5-9.4 ^b	98%	
Norm	Norm	AP-3	LV-S3	243	9.6	9.05	9.87	9.6-9.4 ^b	99%	H
Max	Norm	AP-4				9.5-9.3 ^b	99%	H		
		AP-5				9.76	10.52	10.0-9.7 ^b	99%	V
		AP-6				9.3-9.1 ^b	99%			
Norm	Norm	AP-3	HV-S3	313	1.7	4.07	4.88	9.4-9.5	99%	H
		AP-5						9.3-9.0	99%	V
		AP-7						9.0-8.5	99%	
Max	Norm	AP-4				7.42	8.13	9.2-9.3	99%	H
		AP-6				9.4-9.0	99%	V		
Max	Norm	AP-8				HV-S3	365	0.8 ^e	7.42	8.13
Max	Max	AP-9	HV-S3	365	1.5	7.63	8.34	12.8 ^f	98%	

- Dilution cases are defined by the combination of stack and ISA conditions from Table 4.1.
- LV-S3 aerodynamic diameters from the un-calibrated APS are FIO.
- Diluter Orientation: H=Horizontal, V=Vertical. HV-S3 tests in the vertical orientation were 20° from vertical due to the space constraints in using the 32-inch diluter
- LV-S3 AP-2 conditioned air flow was incorrectly set at 10.34 scfm instead of 10.52 scfm, so the sampling rate from the chamber is a little low.
- HV-S3 AP-8 humidity control for the environmental chamber was erroneously limited, so the target humidity of 1.5% was not achieved. The limitation was discovered and disabled for AP-9.
- The APS was not available during HV-S3 AP-9, so the AD is from OPC measurements. This is expected to be an overestimate compared with the APS measurement due to coarser size bins.

5.3 Operational Considerations

There are a number of operational concerns identified in the course of testing that may impact the actual installation of equipment in these facilities.

The primary assumption made with these tests was that dilution was the preferred method for sample temperature and humidity reduction. However, the impact of dilution is that the ability to detect low level concentrations of constituents of interest with the sample monitor equipment is reduced by the dilution factor. For example, for the LV-S3 normal stack condition, diluted with ISA at normal conditions, the dilution flow rate is 11 times that of the stack sample flow rate (at standard conditions). This means that the sample concentration is reduced by an order of magnitude, and that the measurements reported by the stack monitor equipment must either be adjusted automatically to account for the sample dilution, or monitored and adjusted off-line to determine the true concentration in the stack exhaust. Under these conditions the instrument detection limit would effectively be an order of magnitude higher (less sensitive) than its actual detection limit due to the dilution in the sample, and any alarm levels will need to consider dilution.

Additionally, the simplest method for sample dilution was initially assumed to be a conservative dilution rate that could be fixed to apply for all anticipated stack conditions. This means that a high dilution factor is used, which maximizes the loss of instrument sensitivity. In addition, potential impact category (PIC)-1 stacks, which include the LV-S3, HV-S3A, and HV-S3B, require both a record sampler and a continuous air monitor. While the CAM can utilize a fixed sample flow rate, the record sampler requires that sampling rates be proportional to the stack flow rate. As was listed in Table 2.1, the stack velocities vary by a factor of 1.6 to 2.4 between the minimum and maximum flow conditions for these stacks. This means that, if a fixed dilution flow rate is preferred, it may need to be a higher flow rate than described in this report to accommodate the fluctuations in stack velocity. If a fixed dilution flow rate is prescribed, and the stack sample rate is varied, the sample dilution rate will not be a constant value. This impacts the interpretation of the concentration data from the stack monitoring equipment, and requires a shrouded probe that is rated for the range of stack sample rates.

During these tests, we observed that detection of condensation within the sample conditioning system was not obvious. If large amounts of condensation were present, the filter paper would be saturated, and a pressure signal was observed in the sample MFC. However, a large amount of condensation is not expected within the porous tube diluter. Instead, small amounts of water may condense at intermittent intervals if the heat tape is not sufficiently heating the upstream end of the diluter inlet/housing. During normal operation, condensation is not anticipated to be of concern. However, there are certain periods within the plant life cycle that may have a higher potential for condensation. For example, the melters in both the LAW and HLW facilities will be replaced at approximately 5 year intervals. Therefore, there will be start-up and shut-down periods over the course of the facility life. During these periods, ensuring that the dilution air is delivered first, followed by the sample air as well as pre-heating tubing with heat tape, will mitigate condensation formation. However, the occasional risk of condensation may warrant the addition of a drain port to remove condensed moisture from the sample transport system.

6.0 References

- 10 CFR 830, Subpart A. "Quality Assurance Requirements." *Code of Federal Regulations*, U.S. Department of Energy.
- 40 CFR 53, Subpart F. "Procedures for Testing Performance Characteristics of Class II Equivalent Methods for PM_{2.5}." *Code of Federal Regulations*, U.S. Environmental Protection Agency.
- 40 CFR 60, Appendix A, Method 1. "Method 1—Sample and Velocity Traverses for Stationary Sources." *Code of Federal Regulations*, U.S. Environmental Protection Agency.
- 40 CFR 61, Subpart H. "National Emission Standard for Emissions of Radionuclides other than Radon from Department of Energy Facilities." *Code of Federal Regulations*, U.S. Environmental Protection Agency.
- American National Standards Institute (ANSI). 1999^a. *Sampling and Monitoring Releases of Airborne Radioactive Substances from the Stacks and Ducts of Nuclear Facilities*. ANSI/HPS N13.1—1999, McLean, VA.
- American Society of Mechanical Engineers (ASME). 2001. *Quality Assurance Requirements for Nuclear Facility Applications*. NQA-1-2000, New York, NY.
- DOE Order 414.1C. "Quality Assurance." U.S. Department of Energy, Washington, D.C.
- Gupta R and AR McFarland. 2001. Experimental Study of Aerosol Deposition in Flow Splitters with Turbulent Flow. *Aerosol Sci. Technol.* 34. 216-226.
- Hazen H, Memo to D Kurath. BNI CCN 228831 WA09 Transmittal of Memo CCN 228831 Supplemental Information Supporting High Temperature Probe Testing and Update to LV-S2 Stack Temperature, dated 21 March 2011, March 24, 2011, CCN 232711.
- Kesavan J and RW Doherty. 2000. Use of Fluorescein in Aerosol Studies. Edgewood Chemical Biological Center Technical Report, ECBC-TR-103.
- Lab Impex Systems. 2014. Product Datasheet SmartCAM Alpha Beta in Air Monitor. Datasheet No L236D. Available Online: http://www.labimpex.com/Resources/Resource/L236D_SmartCAM.pdf
- Liu, BYH, JK Agarwal. 1974. Experimental Observation of Aerosol Deposition in Turbulent Flow. *Aerosol Science.* 5, 145-155.
- McFarland AR, A Mohan, NH Ramakrishna, JL Rea and J Thompson. 2000. DEPOSITION 2001a, Version 1.0. Deposition: Software to Calculate Particle Penetration through Aerosol Transport Systems. Texas A&M University. NUREG/GR-0006. College Station, TX.
- Mott Corporation. 2008. Inertial Gas Sampling Filters. Available Online: http://www.mottcorp.com/resource/pdf/PMGASSAMP_Brochure.pdf

^a The standard was reaffirmed in 2011 and is identical to the 1999 version, plus an errata list. Regulations have not been updated, so the 1999 version is referenced.

Mwembeshi M, Memo to J Glissmeyer. May 13, 2008. BNI CCN 179069. Stack Conditions Data for Emission Units LV-S2, LV-S3 & HV-S3A&B.

Mwembeshi M, Memo to H Hazen. April 21, 2010. BNI CCN 216991. Quality of WTP Instrument Service Air (ISA).

Mwembeshi M, Memo to H Hazen. February 10, 2012. BNI CCN 244088. Updated Stack Flowrate, Temperature, and Relative Humidity Data for HLW Melter Offgas Emission Units HV-S3A and HV-S3B.

Mwembeshi M, Memo to H Hazen. February 9, 2012. BNI CCN 244647. Superseding CCN 213167 with Updated Stack Temperature and Relative Humidity Data for LAW Melter Offgas Emission Unit LV-S3. Updated Process Data is Sourced from Calculation Change Notice 24590-LW-M4E-LOP-00009.

Olan-Figueroa, E, AR McFarland, CA Ortiz. 1982. Flattening Coefficient for DOP and Oleic Acid Droplets Deposited on Treated Glass Slides. American Industrial Hygiene Association Journal, 43 (6), 395-399.

Peterson, R., July 24, 2013. WTP/RPP-MOA-PNNL-00738. Memorandum of Agreement 24590-QL-HC9-WA49-00001, Work Authorization 09 – Project 53024 Mott Diluter Based High Temperature Sample Conditioning Test Results for LV-S3.

Thermotron. 2009. SE-Series Environmental Chamber Instruction Manual, Revision 1. Holland, MI.

Tolocka, MP, PT Tseng, RW Wiener. 2001. Optimization of the Wash-Off Method for Measuring Aerosol Concentrations. Aerosol Science and Technology. 34 (5), 416-421.

Appendix A

LV-S3 Test Data Sheets

A.1 LV-S3 Temperature and Humidity Test Data Sheets

TDP-WTPSP-635
TH p 4 of 15

HIGH TEMPERATURE PROBE TESTING - Temperature / Humidity Only

Run No. TH-1
Date 5/3/13
Start/End Time 11:30/13:30
Testers JEF

Facility / Condition LV-S3 Normal
Chamber Set Point 243°F / 9.6% RH
Chamber Temp #DIV/0! deg F
Diluter Orientation Horiz or Vert

1/5 6/19/13

	Start	Finish	
Time	11:30	13:30	
Chamber Temp	243	243	°F
Chamber Humidity	9.6	9.6	RH
Dilution flowcontroller	9.05	9.05	scfm
Dilution Dew Pt	-30	-15	°F
Dilution Temp	76	77	°F
Dilution P	15.3	15.3	psia
Sampling flowcontroller	9.87	9.87	scfm
Sampling Dew Pt	45	46	°F
Sampling Temp	82	83	°F
Sampling P	12.6	12.6	psia
Ambient pressure	1010	1008	mbar
Ambient humidity	26.7	26.0	RH
Ambient Temp	76.3	77.1	°F

Instruments Used:	Cal Due
Thermotron SE-2000-4 Env Chamber S/N 42857	4/2/2014
Alicat MCR-500SLPM MFC SN 68858	2/4/2014
Alicat MCR-500SLPM-D MFC SN 68857	4/3/2014
Vaisala MI70/HMP77B S/N G5230040/H0320001	1/31/2014
Vaisala MI70/DMP74B S/N G5230040/H0320001	1/31/2014
Mott Corp Diluter Model 7610S-1.375-24-2-AB	N/A
Fisher Dew Point Pen S/N 122277883	5/16/2014
N/A	

un-calibrated thermocouple 1/5 5/24/13

Notes: Had to install/switch thermocouples during pre-test/startup activities. Ignore T7 & T8 values before 10:07. Start chamber at 0.8% RH. Increase to 30%, then 6.0%, 8.0%, 9.0%, & 9.6%. T2-dil-0in thermocouple temperature is a bit lower than the LV-S3 Norm dew point. I re-affixed the thermocouple this morning, so it may be closer to the porous section than in previous tests. If it's catching some of the cold-down from the dilution air, it's not a great indicator of condensation potential. We'll check the water indicator dots... T2-dil-0in thermocouple may have come off of the wall prior to disassembly... Rather, it was disconnected when disassembled, and probably occurred during disassembly. Water indicator dots are all white.

"For Information Only" Data Files

Environmental Chamber Data: 130503-lvs3-norm-24in-mott.csv
Vaisala Dew Point Data: 2013-05-03 10-03.csv
Alicat Data: 20130503-0951-alicat.dat

Entries made by: <u>JULIA FLAHERTY</u> Signature/date <u>JEF 5/3/13</u>	Technical Data Review performed by: <u>Joseph Glavic</u> Signature/date <u>7/16/13</u>
--	---

TDP-WTPSP-635
TH p5 of 15

HIGH TEMPERATURE PROBE TESTING - Temperature / Humidity Only

Run No. TH-2
Date 5/6/13
Start/End Time 11:00 / 13:15
Testers JEF, MSP

Facility / Condition LV-S3 Maximum
Chamber Set Point 282°F / 5.6% RH
Chamber Temp #DIV/0! deg F *5/4/13*
Diluter Orientation Horiz or Vert

	Start	Finish	
Time	11:00	13:15	
Chamber Temp	282	282	°F
Chamber Humidity	5.6	5.4	RH
Dilution flowcontroller	9.97	9.97	scfm
Dilution Dew Pt	-34	-21	°F
Dilution Temp	79	82	°F
Dilution P	15.2	15.2	psia
Sampling flowcontroller	10.72	10.72	scfm
Sampling Dew Pt	39	36	°F
Sampling Temp	83	85	°F
Sampling P	12.2	12.1	psia
Ambient pressure	995.5	993.7	mbar
Ambient humidity	24.8	23.6	RH
Ambient Temp	77.2	78.7	°F

Instruments Used:	Cal Due
Theratron SE-2000-4 Env Chamber S/N 42857	4/2/2014
Alicat MCR-500SLPM MFC SN 68858	2/4/2014
Alicat MCR-500SLPM-D MFC SN 68857	4/3/2014
Vaisala MI70/HMP77B S/N G5230040/H0320001	1/31/2014
Vaisala MI70/DMP74B S/N G5230040/H0320001	1/31/2014
Mott Corp Diluter Model 7610S-1.375-24-2-AB	N/A
Fisher Dew Point Pen S/N 122277883	5/16/2014
N/A	

un-calibrated thermocouple 5/24/13

Notes: Replaced desiccant prior to this test.
This is a test with the chamber set to LV-S3 Max conditions and mass flow controllers set to flows calculated for instrument service air (dilution air) max conditions (80°F / -20°F dp).
Programmed chamber to start at 282°F and 0.5% RH, but that couldn't be achieved. 2 hrs after the chamber started, it was ~ 270°F and 0.8% RH.
Step up to 282°F / 0.8% RH and slowly increase humidity.
Note: The wall temperature (T2-dil.oin) is near the chamber dew pt. At 12:33, wrapped the nut to see how much T8-nut increases. The Tdil-12in increased, but T2-dil.oin did not. Seems suspicious. May want to increase humidity after this test to see if it tracks...
Water indicator coils are still white... Marker marks look about the same, too (no water erasure).

"For Information Only" Data Files
Environmental Chamber Data: 130506-1v53-max-norm-24in-mott.csv
Vaisala Dew Point Data: 2013-05-06-09-06.csv
Alicat Data: 20130506-0903-alicat.dat

Entries made by: <u>JULIA FLAHERTY</u> Signature/date <u>JEF 5/6/13</u>	Technical Data Review performed by: Signature/date <u>Charles G. Lovell 5/10/13</u>
--	--

TDP-WTPSP-635
TH p6 of 15

HIGH TEMPERATURE PROBE TESTING - Temperature / Humidity Only

Run No. TH-3
Date 5/6/2013
Start/End Time 16:20/17:30
Testers JEF

Facility / Condition LV-S3 Normal
Chamber Set Point 243°F / 9.6% RH
Chamber Temp #DIV/0! deg F JEF 6/4/13
Diluter Orientation Horiz or Vert

	Start	Finish	
Time	16:20	17:30	
Chamber Temp	243	243	°F
Chamber Humidity	9.61	9.61	RH
Dilution flowcontroller	997	997	scfm
Dilution Dew Pt	20	29	°F
Dilution Temp	86	85	°F
Dilution P	15.1	15.1	psia
Sampling flowcontroller	10.72	10.72	scfm
Sampling Dew Pt	40	43	°F
Sampling Temp	87	85	°F
Sampling P	12.05	12.05	psia
Ambient pressure	992.6	990.8	mbar
Ambient humidity	16.0	15.9	RH
Ambient Temp	80.1	79.7	°F

Instruments Used:	Cal Due
Thermotron SE-2000-4 Env Chamber S/N 42857	4/2/2014
Alicat MCR-500SLPM MFC SN 68858	2/4/2014
Alicat MCR-500SLPM-D MFC SN 68857	4/3/2014
Vaisala MI70/HMP77B S/N G5230040/H0320001	1/31/2014
Vaisala MI70/DMP74B S/N G5230040/H0320001	1/31/2014
Mott Corp Diluter Model 7610S-1.375-24-2-AB	N/A
Fisher Dew Point Pen S/N 122277883	5/16/2014
N/A	

← un-calibrated thermocouple JEF 5/24/13

Notes: Desiccant will need to be replaced after this test.
Should be okay with our room air conditions. PsychCalc resultant dew point is 65°F & dry bulb is 100°F. (243°F/9.6% w/ 85°F/30°F dp → 99.6°F / (65.0°F dp) ↳ 0.8 scfm ↳ 9.80 scfm
Ran the heat tape at 223°F, 20°F cooler than the dry bulb in the chamber to get the centerline air temperature near the chamber dry bulb. This brings the temperature of the thermocouple on the wall (T2 dil-0in) to just a few degrees below the dew point.
Check the water indicator pen dots after the test. Bottom & top at the upstream end were in contact with water. Dots at downstream end are still white.

"For Information Only" Data Files
Environmental Chamber Data: 130506-lvs3_max_norm-24in-mott.csv
Vaisala Dew Point Data: 2013-05-06-15-38.csv
Alicat Data: 20130506-0903-alicat.dat

Entries made by: JULIA FLAHERTY
Signature/date JEF 5/6/2013
Technical Data Review performed by:
Signature/date Elizabeth Glavin 7/16/13

Bottom Side Top

← Water indicator dots on the upstream end of the Mott diluter show some red dye, indicating that it was in contact with water at some point during the test.

TDP-WTPSP-635
TH p7 of 15

HIGH TEMPERATURE PROBE TESTING - Temperature / Humidity Only

Run No. TH- 4
Date 5/7/13
Start/End Time 11:40 / 13:10
Testers JEF

Facility / Condition LV-S3 Min
Chamber Set Point 185°F / 16.9%RH
Chamber Temp #DIV/0! deg F ← 18.0/4/13
Diluter Orientation Horiz or Vert

	Start	Finish	
Time	11:40	13:10	
Chamber Temp	185	185	°F
Chamber Humidity	16.9	16.9	RH
Dilution flowcontroller	5.09	5.09	scfm
Dilution Dew Pt	-31	-26	°F
Dilution Temp	75.7	76.9	°F
Dilution P	14.7	14.7	psia
Sampling flowcontroller	6.06	6.06	scfm
Sampling Dew Pt	52	52	°F
Sampling Temp	83	84	°F
Sampling P	13.3	13.3	psia
Ambient pressure	994.9	994.2	mbar
Ambient humidity	27.8	27.8	RH
Ambient Temp	75.6	75.7	°F

Instruments Used:	Cal Due
ThermoTron SE-2000-4 Env Chamber S/N 42857	4/2/2014
Alicat MCR-500SLPM MFC SN 68858	2/4/2014
Alicat MCR-500SLPM-D MFC SN 68857	4/3/2014
Vaisala MI70/HMP77B S/N G5230040/H0320001	1/31/2014
Vaisala MI70/DMP74B S/N G5230040/H0320001	1/31/2014
Mott Corp Diluter Model 7610S-1.375-24-2-AB	N/A
Fisher Dew Point Pen S/N 122277883	5/16/2014
N/A	

← un-calibrated thermocouple 7/5/24/13

Notes: Replaced desiccant prior to this test.
 ~8:50 wrapped the upstream nut (location where T8-nut is affixed) in insulation. Try to increase temperature at T2-dil.0in.
 Initially set the heat tape to 165°F, but T2-dil.0in was still at 98°F, so increased heat tape to 185°F @ ~9:11. (Target is >114°F)
 ~10:00 T2-dil.0in is still only 103°F, so increased heat tape to 205°F.
 ↳ RH at 11% or 99°F dp.
 ~10:45 move T8-nut to the gap between the nut & mott housing. Check the wall outside temperature against inside temperature (T8 vs T2) for some indication of dilution air influence on T2.
 Water indicator dots are white at the end of the test, at both ends.

"For Information Only" Data Files

Environmental Chamber Data: 130507-lvs3-min-24in-mott.csv
 Vaisala Dew Point Data: 2013-05-07 8:43.csv
 Alicat Data: 20130507-0838-alicat.dat

Entries made by: <u>JULIA FLAHERTY</u> Signature/date <u>Jab Flaherty 5/7/13</u>	Technical Data Review performed by: <u>7/16/13</u> Signature/date <u>Chabell Boland 7/13/13</u> <u>7/16/13</u>
---	---

TDP-WTPSP-635
TH p8 of 15

HIGH TEMPERATURE PROBE TESTING - Temperature / Humidity Only

Run No. TH- 5
Date 5/10/13
Start/End Time 10:45/12:00
Testers JEF

Facility / Condition LV-S3 Maximum
Chamber Set Point 282°F / 5.6%RH
Chamber Temp #DIV/0! deg F
Diluter Orientation Horiz or Vert

J.F. 6/11/13

	Start	Finish	
Time	10:45	12:00	
Chamber Temp	282	282	°F
Chamber Humidity	5.6	5.6	RH
Dilution flowcontroller	9.76	9.76	scfm
Dilution Dew Pt	9	11	°F
Dilution Temp	85	85	°F
Dilution P	15.3	15.3	psia
Sampling flowcontroller	10.52	10.52	scfm
Sampling Dew Pt	45	47	°F
Sampling Temp	88	89	°F
Sampling P	12.3	12.3	psia
Ambient pressure	1005	1004	mbar
Ambient humidity	28.5	28.1	RH
Ambient Temp	81	82	°F

Instruments Used:	Cal Due
Thermotron SE-2000-4 Env Chamber S/N 42857	4/2/2014
Alicat MCR-500SLPM MFC SN 68858	2/4/2014
Alicat MCR-500SLPM-D MFC SN 68857	4/3/2014
Vaisala MI70/HMP77B S/N G5230040/H0320001	1/31/2014
Vaisala MI70/DMP74B S/N G5230040/H0320001	1/31/2014
Mott Corp Diluter Model 7610S-1.375-24-2-AB	N/A
Fisher Dew Point Pen S/N 122277883	5/16/2014
N/A	

← un-calibrated thermocouple J.F. 5/24/13

Notes: Insulation installed over heat tape (re-wrapped yesterday).

One layer of silicone insulation installed over the upstream nut covering T8-nut, which is in the gap btwn the nut & mott housing.

Started heat tape at 244°F (calibration curve btwn Chamber Thermocouple & omega controller: $\Omega = 19.934 + 0.795 \times (\text{Chamber})$)

Started chamber at 270°F / 0.8% RH. Takes a bit of time to get up to 282°F. Need to increase humidity first.

Dew point at start-up was ~ -25°F, so it's increased quickly in ~2 hrs. Will need to replace desiccant after this test.

~9:06 tried to drain water from filter & the drain was stuck open, so had to stop flow momentarily to get it to close. ~9:14 opened up system briefly to check downstream water indicator dots - still looked white.

During test duration, Ω heat tape set to 244°F.

PsyCalc: 282°F / 5.6% RH / 0.74 scfm + 81°F / 0°F dp / 9.60 scfm → 99°F db / 61°F dp ✓ ok w/ our conditions.

"For Information Only" Data Files

Environmental Chamber Data: 130510-LV3-max-24in-mott.csv

Vaisala Dew Point Data: 2013-05-10 8-31.csv

Alicat Data: 20130510-0824-alicat.dat

One upstream water indicator dot was pink... probably turned during start-up.

Entries made by: <u>JULIA FLAHERTY</u>	Technical Data Review performed by:
Signature/date: <u>[Signature]</u> 5/10/13	Signature/date: <u>[Signature]</u> 7/16/13

TDP-WTPSP-635
TH p9 of 15

HIGH TEMPERATURE PROBE TESTING - Temperature / Humidity Only

Run No. TH-6
Date 5/13/13
Start/End Time 10:00 / 13:30
Testers JEF
Facility / Condition LV-S3 Normal
Chamber Set Point 243°F / 9.6% RH
Chamber Temp #DIV/0! deg F
Diluter Orientation Horiz or Vert

	Start	Finish	
Time	10:00	13:25	
Chamber Temp	243	243	°F
Chamber Humidity	9.6	9.6	RH
Dilution flowcontroller	9.97	9.97	scfm
Dilution Dew Pt	-32	10	°F
Dilution Temp	78.8	79.5	°F
Dilution P	15.3	15.3	psia
Sampling flowcontroller	10.72	10.72	scfm
Sampling Dew Pt	34	40	°F
Sampling Temp	82	83	°F
Sampling P	12.2	12.2	psia
Ambient pressure	1000	1001	mbar
Ambient humidity	39.7%	41.1%	RH
Ambient Temp	77.6	78.5	°F

Instruments Used:	Cal Due
Thermotron SE-2000-4 Env Chamber S/N 42857	4/2/2014
Alicat MCR-500SLPM MFC SN 68858	2/4/2014
Alicat MCR-500SLPM-D MFC SN 68857	4/3/2014
Vaisala MI70/HMP77B S/N G5230040/H0320001	1/31/2014
Vaisala MI70/DMP74B S/N G5230040/H0320001	1/31/2014
Mott Corp Diluter Model 7610S-1.375-24-2-AB	N/A
Fisher Dew Point Pen S/N 122277883	5/16/2014
N/A	

un-calibrated thermocouple 5/24/13

Notes: Replaced desiccant at the start of the day.
One layer of Silicene insulation installed over the upstream nut covering T8-nut, which is in the gap btwn the nut & mott housing.
Heat tape set to 214°F (calibration curve btwn Chamber & Omega; Ω = 19.934 + 0.795 * Chamber. Chamber = 243 Ω = 214).
Started chamber at 243°F / 0.8% RH.
~11:15 noticed that it's raining a bit. That may impact how quickly the desiccant becomes used-up. ~11:45 still some rain sprinkles. Humidity in bldg ~42%.
~12:15 The sight glass for the filter & coalescer upstream of the desiccant bowl are both nebuly full of water.
13:21 ISA dp ↑ rapidly... Need to stop the test at 13:25.
Downstream water indicator dots are all white.
Three upstream water indicator dots are pink. Don't know when that could've happened. I also had some green markings that appear to have mostly washed off...

"For Information Only" Data Files
Environmental Chamber Data: 130513-lvs3-norm-24in-mott.csv
Vaisala Dew Point Data: 2013-05-13 8-39.csv
Alicat Data: 20130513-0831-alicat.dat.

Entries made by: JULIA FLAHERTY
Signature/date [Signature] 5/13/13
Technical Data Review performed by: Elizabeth G. [Signature]
Signature/date [Signature] 7/16/13

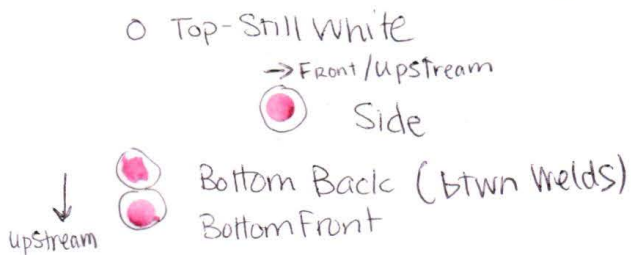

TDP-WTPSP-635
TH p10 of 15

HIGH TEMPERATURE PROBE TESTING - Temperature / Humidity Only

Run No. TH-7
Date 5/13/13
Start/End Time 16:05 / 17:05
Testers JFF

Facility / Condition LV-S3 Normal
Chamber Set Point 243°F / 9.6% RH
Chamber Temp #DIV/0! deg.F
Diluter Orientation Horiz or Vert

5/14/13

	Start	Finish	
Time	16:05	17:05	
Chamber Temp	243	243	°F
Chamber Humidity	9.6	9.6	RH
Dilution flowcontroller	9.97	9.97	scfm
Dilution Dew Pt	-19	-13	°F
Dilution Temp	75.9	79.3	°F
Dilution P	15.2	15.2	psia
Sampling flowcontroller	10.72	10.72	scfm
Sampling Dew Pt	34	34	°F
Sampling Temp	80	82	°F
Sampling P	12.2	12.2	psia
Ambient pressure	1000	999.6	mbar
Ambient humidity	43.2%	48.8	RH
Ambient Temp	78.0	76.4	°F

Instruments Used:	Cal Due
Thermotron SE-2000-4 Env Chamber S/N 42857	4/2/2014
Alicat MCR-500SLPM MFC SN 68858	2/4/2014
Alicat MCR-500SLPM-D MFC SN 68857	4/3/2014
Vaisala MI70/HMP77B S/N G5230040/H0320001	1/31/2014
Vaisala MI70/DMP74B S/N G5230040/H0320001	1/31/2014
Mott Corp Diluter Model 7610S-1.375-24-2-AB	N/A
Fisher Dew Point Pen S/N 122277883	5/16/2014
N/A	

← un-calibrated thermocouple 5/24/13

Notes: Replaced desiccant just before this test.
Outside, the rain has stopped and the sun has come out.
The T2-dil. in temperature dropped to ~132 (less than dew pt -135)
so this one may condense, too. Perhaps the heat tape needs
to be a bit hotter than 236°F...
Downstream water indicator dots (WID) are all white.
Upstream WIDs are all pink. Green marker has been
erased a bit, & there is a puddle of greenish water.

"For Information Only" Data Files
Environmental Chamber Data: 130513-lvs3-norm-24in-mott.csv
Vaisala Dew Point Data: 2013-05-13 15-07.csv
Alicat Data: 20130513-#35-alicat.dat
#5/13-1435

Entries made by: JULIA FLAHERTY
Signature/date *Jal Flaherty* 5/13/13
Technical Data Review performed by:
Signature/date *Charlott G. Lorch* 7/18/13

- Top
- Side
- Bottom Back (btwn welds)
- Bottom Front

TDP-WTPSP-635
TH p11 of 15

HIGH TEMPERATURE PROBE TESTING - Temperature / Humidity Only

Run No. TH-8
Date 5/14/13
Start/End Time 12:15 / 13:30
Testers JEF

Facility / Condition LV-S3 Normal
Chamber Set Point 243°F / 96% RH
Chamber Temp #DIV/0! deg F → JEF 6/14/13
Diluter Orientation Horiz or Vert

	Start	Finish	
Time	12:15	12:05	13:30
Chamber Temp	243	243	°F
Chamber Humidity	9.6	9.6	RH
Dilution flowcontroller	9.97	9.97	scfm
Dilution Dew Pt	-13	-14	°F
Dilution P	78.3	79.1	°F
Dilution P	15.3	15.3	psia
Sampling flowcontroller	10.72	10.72	scfm
Sampling Dew Pt	30	28	°F
Sampling Temp	80	82	°F
Sampling P	12.30	12.3	psia
Ambient pressure	1005	1004	mbar
Ambient humidity	22.1%	18.6%	RH
Ambient Temp	75.8	75.9	°F

Instruments Used:	Cal Due
Thermotron SE-2000-4 Env Chamber S/N 42857	4/2/2014
Alicat MCR-500SLPM MFC SN 68858	2/4/2014
Alicat MCR-500SLPM-D MFC SN 68857	4/3/2014
Vaisala MI70/HMP77B S/N G5230040/H0320001	1/31/2014
Vaisala MI70/DMP74B S/N G5230040/H0320001	1/31/2014
Mott Corp Diluter Model 7610S-1.375-24-2-AB	N/A
Fisher Dew Point Pen S/N 122277883	5/16/2014
N/A	

un-calibrated thermocouple JEF 5/24/13

Notes: Replaced the top half of the desiccant prior to this test.

123
JEF
5/14

Dew point of dilution air starts out at -20°F at 10:40.
Set heat tape to 243°F, which will be a much higher temperature measured by the chamber (282°F). ^{136 JEF 5/14/13} Added a thermocouple from the Omega controller to the neck of the port flange - its reading 118°F, which means ~245°F in "real" values. So not much cooling... Nevermind.
Wall temperature (T2-dil-0in) during rest is ~149°F. Should be free of condensation.
Omega controller (T2) is 128°F at 12:50 (+22°F real). Lots of cooling.
Add a "why-bother" layer of silicone insulation on top of the existing layer to close the gap w/ the wall.
No noticeable change in T2 at 13:15.
Downstream water indicator dots are white, some upstream dots were pink. Top looks a little pink, two bottom ones are split - one btwn welds is pink, the upstream one is white.
"For Information Only" Data Files Green marker seems un-touched. Puddle.
Environmental Chamber Data: 130514-lvs3-norm-24in-mott.csv
Vaisala Dew Point Data: 2013-05-14 10.40.csv
Alicat Data: 20130514-1034-alicat.dat

Entries made by: JULIA FLAHERTY Technical Data Review performed by:
Signature/date JEF 5/14/13 Signature/date Cheryl G. G... 7/16/13

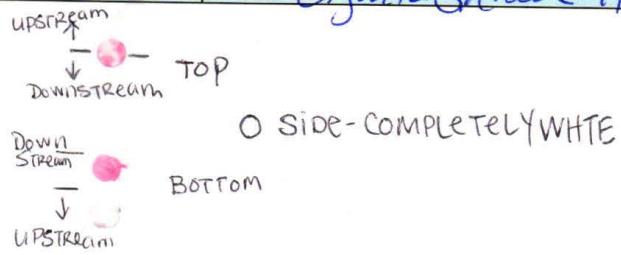

TDP-WTPSP-635
TH p12 of 15

HIGH TEMPERATURE PROBE TESTING - Temperature / Humidity Only

Run No. TH-9
Date 5/23/13
Start/End Time 10:50 / 11:55
Testers JAG, JEF, MSP

Facility / Condition LV-S3 Norm
Chamber Set Point 243°F / 9.6% RH
Chamber Temp #DIV/0! deg F
Diluter Orientation Horiz or Vert

	Start	Finish	
Time	10:50	11:55	
Chamber Temp	244	243	°F
Chamber Humidity	9.5	9.6	RH
Dilution flowcontroller	9.97	9.97	scfm
Dilution Dew Pt	-20	-20	°F
Dilution Temp	72	75	°F
Dilution P	15.3	15.3	psia
Sampling flowcontroller	10.72	10.72	scfm
Sampling Dew Pt	21	23	°F
Sampling Temp	79	82	°F
Sampling P	12.3	12.2	psia
Ambient pressure	1002	1001	mbar
Ambient humidity	30.5	26.9	RH
Ambient Temp	72.7	73.9	°F

Instruments Used:	Cal Due
Thermotron SE-2000-4 Env Chamber S/N 42857	4/2/2014
Alicat MCR-500SLPM MFC SN 68858	2/4/2014
Alicat MCR-500SLPM-D MFC SN 68857	4/3/2014
Vaisala MI70/HMP77B S/N G5230040/H0320001	1/31/2014
Vaisala MI70/DMP74B S/N G5230040/H0320001	1/31/2014
Mott Corp Diluter Model 7610S-1.375-24-2-AB	N/A
Fisher Dew Point Pen S/N 122277883	5/16/2014

← un-calibrated thermocouple # 5/24/13

Notes: Replaced desiccant w/ once-baked desiccant prior to test.
Heat tapes over 1" transport line AND upstream end of MOTT.
Both set to 243°F (~285°F Read thru thermotron TCs).
Omega T3 installed on neck of port flange reads ~126°F.
Water indicator dots on both ends of Mott remain white.

"For Information Only" Data Files

Environmental Chamber Data: 130523-lvs3-norm-24in-mott.csv
Vaisala Dew Point Data: 2013-05-23_954.csv
Alicat Data: 20130523_0942-alicat.dat

Entries made by: JULIA FEATHERY Signature/date <i>Julia Feaherty</i> 5/23/13	Technical Data Review performed by: Signature/date <i>Shelley Gabriel</i> 7/16/13
---	--

TDP-WTPSP-635
TH p13 of 15

HIGH TEMPERATURE PROBE TESTING - Temperature / Humidity Only

Run No. TH-10
Date 5/23/13
Start/End Time 13:40 / 14:40
Testers JEF, MSP

Facility / Condition LV-S3 Norm
Chamber Set Point 243°F / 9.6% RH
Chamber Temp #DIV/0! deg F *at 6/4/13*
Diluter Orientation Horiz or Vert

	Start	Finish	
Time	13:40	14:40	
Chamber Temp	243	243	°F
Chamber Humidity	9.6	9.6	RH
Dilution flowcontroller	9.97	9.97	scfm
Dilution Dew Pt	-17	-15	°F
Dilution Temp	76	76	°F
Dilution P	15.3	15.3	psia
Sampling flowcontroller	10.72	10.72	scfm
Sampling Dew Pt	25	27	°F
Sampling Temp	80	81	°F
Sampling P	12.2	12.2	psia
Ambient pressure	1000	1000	mbar
Ambient humidity	25.0	23.7	RH
Ambient Temp	73.6	74.2	°F

Instruments Used:	Cal Due
Thermotron SE-2000-4 Env Chamber S/N 42857	4/2/2014
Alicat MCR-500SLPM MFC SN 68858	2/4/2014
Alicat MCR-500SLPM-D MFC SN 68857	4/3/2014
Vaisala MI70/HMP77B S/N G5230040/H0320001	1/31/2014
Vaisala MI70/DMP74B S/N G5230040/H0320001	1/31/2014
Mott Corp Diluter Model 7610S-1.375-24-2-AB	N/A
Fisher Dew Point Pen S/N 122277883	5/16/2014
N/A	

← un-calibrated thermocouple *at 5/24/13*

Notes: Same desiccant as TH-9 (once-baked).
Set both heat tapes to 214°F, which should correspond to ~243°F on the thermocouples attached to the chamber.
Omega T3 installed on neck of port flange reads ~126°F.
↑ at around 12:50.
The little orange indicator ball on the stage 1 filter on the drying system disappeared (as in it's full of water) by 14:10. Nothing really visible in the second stage, and dew point is pretty stable, so it should be okay.
~ 14:35, the orange ball on the 2nd stage filter was a little bit below the halfway mark.
All water indicator dots, upstream and downstream, are white.

"For Information Only" Data Files

Environmental Chamber Data: 130523-LV53-norm-24in-mott.csv
Vaisala Dew Point Data: 2013-05-23 9:54.csv
Alicat Data: 20130523-0942-alicat.dat

Entries made by: JULIA FLAHERTY Signature/date [Signature] 5/23/13
Technical Data Review performed by: Elizabeth Glouch Signature/date [Signature] 7/16/13

TDP-WTPSP-635
TH #14 of 15

HIGH TEMPERATURE PROBE TESTING - Temperature / Humidity Only

Run No. TH-11
Date 5/24/13
Start/End Time 10:40 / 11:40
Testers JEF, MSP

Facility / Condition LV-S3 Max
Chamber Set Point 282°F / 5.6% RH
Chamber Temp #DIV/0! deg F e 11/6/13
Diluter Orientation Horiz or Vert

	Start	Finish	
Time	10:40	11:40	
Chamber Temp	282	282	°F
Chamber Humidity	5.6	5.6	RH
Dilution flowcontroller	9.76	9.76	scfm
Dilution Dew Pt	0	4.7	°F
Dilution Temp	75.5	76.5	°F
Dilution P	15.3	15.2	psia
Sampling flowcontroller	10.52	10.52	scfm
Sampling Dew Pt	43	43	°F
Sampling Temp	85	86	°F
Sampling P	12.2	12.2	psia
Ambient pressure	1001	1001	mbar
Ambient humidity	33.6	34.0	RH
Ambient Temp	78.3	79.0	°F

Instruments Used:	Cal Due
Thermotron SE-2000-4 Env Chamber S/N 42857	4/2/2014
Alicat MCR-500SLPM MFC SN 68858	2/4/2014
Alicat MCR-500SLPM-D MFC SN 68857	4/3/2014
Vaisala MI70/HMP77B S/N G5230040/H0320001	1/31/2014
Vaisala MI70/DMP74B S/N G5230040/H0320001	1/31/2014
Mott Corp Diluter Model 7610S-1.375-24-2-AB	N/A
Fisher Dew Point Pen S/N 122277883	5/16/2014
N/A	

un-calibrated thermocouple 11/5/24/13

Notes: Replaced desiccant with another once-baked gallon prior to test. Suspect desiccant efficiency is impacted by oil in air breaking through Stage 2 filter.
Rainy this morning, but the rain appears to have stopped at 9:00. Set both Omega heat tapes to 244°F ($\Omega = 19.9 + 0.795 \cdot 282$).
09:15 - Omega T3 installed on neck of port flange reads ~124°F (which is really $(124 - 19.9) / 0.795 = 131^\circ\text{F}$).
Dry air condition is not ideal, bounces btwn -5 & +5°F dp. PsyCalc estimates conditioned air will be 94°F db & 62°F dp w/ conditioned air = 75°F db / 0°F dp, which is OK. We may even be OK w/ 20°F dp conditioned air, which gives 64°F conditioned air.
Maybe I risk it... The once-baked desiccant seems to be pretty stable. At the end of the test, all water indicator dets, both upstream and downstream, were white.

"For Information Only" Data Files

Environmental Chamber Data: 130524-LV3-max-horm-24in-mott.csv
Vaisala Dew Point Data: 2013-05-24-09-37.csv
Alicat Data: 20130524-0905-alicat.dat

Entries made by: JULIA FLAHERTY Signature/date: <i>Julia Flaherty</i> 5/24/13	Technical Data Review performed by: Signature/date: <i>Charlott Colwell</i> 7/18/13
--	--

TDP-WTPSP-635
TH p 15 of 15

HIGH TEMPERATURE PROBE TESTING - Temperature / Humidity Only

Run No. TH-12
Date 5/24/13
Start/End Time 13:50/14:50
Testers JFF, MSP

Facility / Condition LV-S3 NORM
Chamber Set Point 243°F / 9.6% RH
Chamber Temp #DIV/0! deg F e J.F. 5/24/13
Diluter Orientation Horiz or Vert

	Start	Finish	
Time	13:50	14:50	
Chamber Temp	242	243	°F
Chamber Humidity	9.7	9.6	RH
Dilution flowcontroller	9.05	9.05	scfm
Dilution Dew Pt	-22	-15	°F
Dilution Temp	74.6	78.8	°F
Dilution P	15.2	15.2	psia
Sampling flowcontroller	9.87	9.87	scfm
Sampling Dew Pt	28	28	°F
Sampling Temp	83	85	°F
Sampling P	12.4	12.4	psia
Ambient pressure	1001	1000	mbar
Ambient humidity	37.0	37.3	RH
Ambient Temp	79.2	79.6	°F

Instruments Used:	Cal Due
Thermotron SE-2000-4 Env Chamber S/N 42857	4/2/2014
Alicat MCR-500SLPM MFC SN 68858	2/4/2014
Alicat MCR-500SLPM-D MFC SN 68857	4/3/2014
Vaisala MI70/HMP77B S/N G5230040/H0320001	1/31/2014
Vaisala MI70/DMP74B S/N G5230040/H0320001	1/31/2014
Mott Corp Diluter Model 7610S-1.375-24-2-AB	N/A
Fisher Dew Point Pen S/N 122277883	5/16/2014
N/A	

un-calibrated thermocouple J.F. 5/24/13

Notes: Replaced desiccant w/ yet another once-baked gallon prior to this test. Still occasionally rainy outside. Set both Omega heat tapes to 213°F ($\Omega = 19.9 + 0.795 \cdot 243$). During pre-test/start-up, the Vaisala handheld unit shut off and wouldn't turn back on. Pulled the battery to fix. The dew point was moderately high (~20°F), and checked desiccant. The "nut" on the center air line was loose. Significant improvement in dew point with that fix. ~14:30 Omega T3 installed on neck of port flange reads ~137°F. At the end of the test, all water indicator dots, both upstream and downstream, were white.

"For Information Only" Data Files

Environmental Chamber Data: 130524-lvs3-max-norm-24in-mott.csv
Vaisala Dew Point Data: 2013-05-24 12-56.csv
Alicat Data: 20130524-0905-alicat.dat

Entries made by: JULIA FATHERTY
Signature/date: *Julia Fatherly* 5/24/13
Technical Data Review performed by:
Signature/date: *Elizabeth Gabriel Hump*

A.2 LV-S3 Aerosol Penetration Data Sheets

HIGH TEMPERATURE PROBE TESTING - Aerosol Penetration						
Aerosol and Dilution Data						
Run No.	AP-1			Facility	LV-S3	
Date	7/2/2013			Chamber Set Point	75°F / 22% RH	
Start/End Time	14:06 - 14:55			Diluter Flows	Norm, Norm ISA	
Testers	JEF			Diluter Orientation	Horiz	
	Start	Finish		Materials and Equipment Used:		Cal Due
Time	14:06	14:55		Thermotron SE-2000-4 Env Chamber S/N 42857		4/2/2014
Chamber Temp	75	75	°F	Alicat MCR-500SLPM MFC SN 68858		2/4/2014
Chamber Humidity	22%	22%	RH	Alicat MCR-500SLPM-D MFC SN 68857		4/3/2014
Dilution flowcontroller	9.05	9.05	scfm	Vaisala MI70/HMP77B S/N G5230040/H0320001		1/31/2014
Dilution Dew Pt	2.7	38	°F	Vaisala MI70/DMP74B S/N G5230040/H0320001		1/31/2014
Dilution Temp	75	92	°F	Type T Thermocouples T005 & T009		6/18/2014
Dilution P	15.1	15.1	psia	Mott Corp Diluter Model 7610S-1.375-24-2-AB		N/A
Sampling flowcontroller	9.87	9.87	scfm	Fisher Dew Point Pen S/N 122277883		5/16/2014
Sampling Dew Pt	-3.9	24.5	°F	TSI VOAG, Model 345001 S/N 406		N/A
Sampling Temp	74	87	°F	VOAG Aerosol Solution ID AS01 made on 7/1/2013		
Sampling P	13.3	13.3	psia	Hach OPC S/N 1011529009		12/14/2014
Ambient pressure	996.9	996.4	mbar	TSI APS S/N 70907086		N/A
Ambient humidity	38.2%	35.5%	RH			
Ambient Temp	77.7	82.6	°F	Droplet Diameter: $Dd = (6Q/πf)^{(1/3)}$		48.2 μm
VOAG Frequency	43.63	43.61	kHz			
VOAG Syringe Speed	4.6	4.6	$\times 10^{-4}$ cm/s	Aerosol concentration, C		0.0142
VOAG Dispersion Air	10	10	cc/min $\times 100$	Aerosol density, ρ		0.8931
VOAG Dilution Air	65	70	LPM			
				Particle Diameter: $Dp = (C+1)^{(1/3)}Dd$		11.9 μm
				Aerodynamic Diameter: $AD = Dp \cdot \sqrt{\rho/1}$		11.3 μm
Notes: Forgot to open valves on vacuum pump, so first few minutes had low sample flow. Fixed at 14:06.						
/						
<i>Data Files</i>						
Environmental Chamber Data: /						
FIO Vaisala Dew Point Data: N/A						
FIO Alicat Data: /						
FIO APS Data: /						
Entries made by:	Julia Flaherty			Technical Data Review performed by:	Elizabeth Golovich	
Signature/date	On File w/ Original 7/2/2013			Signature/date	On File w/ Original 7/18/2013	

HIGH TEMPERATURE PROBE TESTING - Aerosol Penetration								
Fluorometry Data								
Run No.	AP-1			Facility	LV-S3			
Date	7/2/2013			Chamber Set Point	75°F / 22%RH			
Start/End Time	11:30 / 18:55			Diluter Flows	Norm, Norm ISA			
Testers	JEF			Diluter Orientation	Horiz			
Materials and Equipment Used:				Cal Due				
Turner Trilogy Fluorometer		S/N 72000895		N/A				
Sartorius QS 2000 Lab Balance		S/N 60502077		6/24/2014				
Sartorius CPA 224A Lab Balance		S/N 27950023		9/29/2013				
Aerosol Wash Solution		ID AW02		Made on 7/2/13				
Whatman AutoVial				N/A				
N/A								
	Wash Solution		Fluorescence				RFU/g	Aerosol Penetration
	Sample	Mass (g)	1 - RFU	2 - RFU	3 - RFU	Mean		
Pre-Test Wash	Fittings	68.8240	172.03	171.24	169.73	171.0	2.5	N/A
	Diluter	128.5560	32.51	33.27	32.45	32.7	0.3	
	Solid Std	N/A	2650.14	2650.49	2649.83	2650.2		
	Solution Blank	N/A	55.24	52.44	55.9	54.5		
First Wash	Filter	100.2	6996.81	7015.81	6969.37	6994.0	69.8	0.9909
	Fittings	73.0	632.03	630.42	627.5	630.0	8.6	
	Diluter	149.2	108.02	107.13	107.52	107.6	0.7	
	Solid Std	N/A	2647.7	2648.55	2648.08	2648.1		
	Filter Blank	99.0	25.95	25.05	25.16	25.4	0.3	
	Solution Blank	N/A	57.4	57.31	60.95	58.6		
Second Wash	Filter	100.0	148.03	149.21	148.47	148.6	1.5	0.9895
	Fittings	66.8	89.23	89.34	88.96	89.2	1.3	
	Diluter	140.7	19.48	19.74	19.78	19.7	0.1	
	Solid Std	N/A	2648.71	2649.35	2649.12	2649.1		
	Filter Blank	97.9	24.03	23.32	23.88	23.7	0.2	
	Solution Blank	N/A	58.74	58.47	58.28	58.5		
Third Wash	Filter	94.3	42.48	42.29	42.29	42.4	0.4	0.9883
	Fittings	75.7	65.24	66.84	65.03	65.7	0.9	
	Diluter	141.6	16.27	16.20	16.26	16.2	0.1	
	Solid Std	N/A	2647.76	2648.29	2648.71	2648.3		
	Filter Blank	90.1	11.07	11.02	10.99	11.0	0.1	
	Solution Blank	N/A	59.01	59.23	59.01	59.1		
Notes: Pre-test fitting wash involved swirling AW02, then wiping out with a Kimwipe and adding the Kimwipe to the wash solution.								
2nd wash diluter and fittings did not use autovial.								
3rd wash no autovial on anything.								
Blow out diluter after 1st wash only.								
Entries made by: Julia Flaherty			Technical Data Review performed by: Elizabeth Golovich					
Signature/date: On File w/ Original 7/2/2013			Signature/date: On File w/ Original 7/18/2013					

HIGH TEMPERATURE PROBE TESTING - Aerosol Penetration						
Aerosol and Dilution Data						
Run No.	AP-2			Facility	LV-S3	
Date	7/4/2013			Chamber Set Point	75°F / 40% RH	
Start/End Time	11:41 / 12:21			Diluter Flows	Max, Norm ISA	
Testers	JEF			Diluter Orientation	Horiz	
	Start	Finish		Materials and Equipment Used:		Cal Due
Time	11:41	12:21		Thermotron SE-2000-4 Env Chamber S/N 42857		4/2/2014
Chamber Temp	75	75	°F	Alicat MCR-500SLPM MFC SN 68858		2/4/2014
Chamber Humidity	40%	40%	RH	Alicat MCR-500SLPM-D MFC SN 68857		4/3/2014
Dilution flowcontroller	9.76	9.76	scfm	Vaisala MI70/HMP77B S/N G5230040/H0320001		1/31/2014
Dilution Dew Pt	2.8	22.1	°F	Vaisala MI70/DMP74B S/N G5230040/H0320001		1/31/2014
Dilution Temp	75	84	°F	Type T Thermocouples T005 & T009		6/18/2014
Dilution P	15.2	15.2	psia	Mott Corp Diluter Model 7610S-1.375-24-2-AB		N/A
Sampling flowcontroller	10.34	10.34	scfm	Fisher Dew Point Pen S/N 122277883		5/16/2014
Sampling Dew Pt	1.5	12.5	°F	TSI VOAG, Model 345001 S/N 406		N/A
Sampling Temp	72	80.4	°F	VOAG Aerosol Solution ID AS01 made on 7/1/2013		
Sampling P	13.3	13.2	psia	Hach OPC S/N 1011529009		12/14/2014
Ambient pressure	997.2	996.9	mbar	TSI APS S/N 70907086		N/A
Ambient humidity	33.0%	28.1%	RH			
Ambient Temp	75.9	78.2	°F	Droplet Diameter: $D_d = (6Q/πf)^{(1/3)}$		46.9 μm
VOAG Frequency	47.20	47.20	kHz			
VOAG Syringe Speed	4.6	4.6	x 10 ⁻⁴ cm/s	Aerosol concentration, C		0.0142
VOAG Dispersion Air	10	10	cc/min x 100	Aerosol density, ρ		0.8931
VOAG Dilution Air	70	70	LPM	Particle Diameter: $D_p = (C+I)^{(1/3)}D_d$		11.6 μm
				Aerodynamic Diameter: $AD = D_p \cdot \text{SQRT}(\rho/1)$		11.0 μm
Notes: The desiccant is pretty fresh, but the dew point is fairly high. Check the desiccant bowl fittings after this test.						
/						
Data Files						
Environmental Chamber Data:	130704_lvs3_roomtemp_AP1_AP2.csv					
FIO Vaisala Dew Point Data:	2013-07-04 11_46.csv					
FIO Alicat Data:	20130704_1134_alicat.dat					
FIO APS Data:	test_july_04_2013_1.A21					
Entries made by:	Julia Flaherty			Technical Data Review performed by:	Elizabeth Golovich	
Signature/date	On File w/ Original 7/4/2013			Signature/date	On File w/ Original 7/18/2013	

HIGH TEMPERATURE PROBE TESTING - Aerosol Penetration									
Fluorometry Data									
Run No.		AP-2		Facility		LV-S3			
Date		7/4/2013		Chamber Set Point		75°F / 40% RH			
Start/End Time		10:40 / 13:22		Diluter Flows		Max, Norm ISA			
Testers		JEF		Diluter Orientation		Horiz			
Materials and Equipment Used:							Cal Due		
Turner Trilogy Fluorometer		S/N 720000895		N/A					
Sartorius QS 2000 Lab Balance		S/N 60502077		6/24/2014					
Sartorius CPA 224A Lab Balance		S/N 27950023		9/29/2013					
Aerosol Wash Solution		ID AW03		Made on 7/3/13					
Whatman AutoVial		N/A							
N/A									
		Wash Solution		Fluorescence				Aerosol Penetration	
Sample		Mass (g)		1 - RFU	2 - RFU	3 - RFU	Mean	RFU/g	
Pre-Test Wash	Fittings	56.7	40.85	41.13	40.96	41.0	0.7		
	Diluter	140.2	12.83	13.25	13.05	13.0	0.1	N/A	
	Solid Std	N/A	2632.60	2632.49	2633.39	2632.8			
	Solution Blank	N/A	9.64	9.91	9.72	9.8			
First Wash	Filter	100.4	3445.79	3462.59	3463.27	3457.2	34.4		
	Fittings	63.2	84.08	85.39	85.20	84.9	1.3	0.9843	
	Diluter	150.0	86.87	85.27	84.99	85.7	0.6		
	Solid Std	N/A	2635.71	2635.74	2636.11	2635.9			
	Filter Blank	100.7	24.39	28.31	28.61	27.1	0.3		
	Solution Blank	N/A	9.92	9.85	9.90	9.9			
Second Wash	Filter	96.5	103.96	103.84	104.24	104.0	1.1		
	Fittings	60.5	32.97	32.88	32.91	32.9	0.5	0.9815	
	Diluter	149.0	19.89	19.98	20.04	20.0	0.1		
	Solid Std	N/A	2629.61	2629.45	2629.83	2629.6			
	Filter Blank	96.8	21.35	24.13	24.24	23.2	0.2		
	Solution Blank	N/A	10.4	10.53	10.27	10.4			
Third Wash	Filter	102.3	28.60	30.36	29.02	29.3	0.3		
	Fittings	64.5	26.39	26.47	26.1	26.3	0.4	0.9793	
	Diluter	149.8	15.06	14.84	15.01	15.0	0.1		
	Solid Std	N/A	2623.64	2623.45	2624.14	2623.7			
	Filter Blank	100.2	22.20	23.14	21.56	22.3	0.2		
	Solution Blank	N/A	11.88	11.57	11.33	11.6			
Notes: Filter paper had a yellow spot (of fluorescein), not quite in the middle, but close.									
Did not thoroughly dry fittings or diluter between washes.									
Used AutoVial on everything for the first wash, but only the filters for 2nd and 3rd wash.									
Entries made by: Julia Flaherty			Technical Data Review performed by: Elizabeth Golovich						
Signature/date: On File w/ Original 7/4/2013			Signature/date: On File w/ Original 7/18/2013						

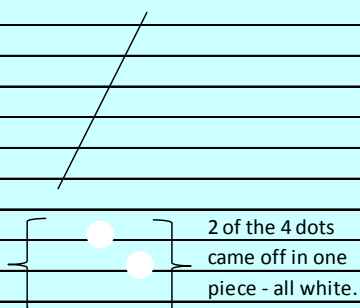
HIGH TEMPERATURE PROBE TESTING - Aerosol Penetration									
Aerosol and Dilution Data									
Run No.	AP-3				Facility	LV-S3			
Date	7/8/2013				Chamber Set Point	243°F / 9.6% RH			
Start/End Time	9:55 / 10:30				Diluter Flows	Norm, Norm ISA			
Testers	JEF, MSP				Diluter Orientation	Horiz			
	Start	Finish			Materials and Equipment Used:				Cal Due
Time	9:55	10:30			Thermotron SE-2000-4 Env Chamber S/N 42857				4/2/2014
Chamber Temp	243	243	°F		Alicat MCR-500SLPM MFC SN 68858				2/4/2014
Chamber Humidity	9.6%	9.6%	RH		Alicat MCR-500SLPM-D MFC SN 68857				4/3/2014
Dilution flowcontroller	9.05	9.05	scfm		Vaisala MI70/HMP77B S/N G5230040/H0320001				1/31/2014
Dilution Dew Pt	-2	7.4	°F		Vaisala MI70/DMP74B S/N G5230040/H0320001				1/31/2014
Dilution Temp	79.2	81.4	°F		Type T Thermocouples T004 - T006, T008, T009				6/18/2014
Dilution P	15.2	15.2	psia		Mott Corp Diluter Model 7610S-1.375-24-2-AB				N/A
Sampling flowcontroller	9.87	9.87	scfm		Fisher Dew Point Pen S/N 122277883				5/16/2014
Sampling Dew Pt	50	51	°F		TSI VOAG, Model 345001 S/N 406				N/A
Sampling Temp	94	95	°F		VOAG Aerosol Solution ID AS01 made on 7/1/2013				
Sampling P	13.3	13.3	psia		Hach OPC S/N 1011529009				12/14/2014
Ambient pressure	999.0	999.2	mbar		TSI APS S/N 70907086				N/A
Ambient humidity	36.1%	37.0%	RH						
Ambient Temp	74.8	75.5	°F		Droplet Diameter: $D_d = (6Q/πf)^{1/3}$				46.5 μm
VOAG Frequency	48.44	48.44	kHz						
VOAG Syringe Speed	4.6	4.6	x 10 ⁻⁴ cm/s		Aerosol concentration, C				0.0142
VOAG Dispersion Air	10	10	cc/min x 100		Aerosol density, ρ				0.8931
VOAG Dilution Air	70	70	LPM						
					Particle Diameter: $D_p = (C+)^{1/3}D_d$				11.5 μm
					Aerodynamic Diameter: $AD = D_p \cdot \sqrt{ρ}$				10.9 μm
Notes:	Turned on flows ~8:47. Heat tapes set to 213°F, which should correspond to ~243°F on our calibrated thermocouples.								
	Increment humidity from 0.8% to 9.6%. (0.8% to 3.0 to 6.0 to 8.0 to 9.0 to 9.6%)								
	At end of test, increase dilution flow to cool diluter. (Heat tapes off)								
	All 3M water indicator dots (4 on upstream end, near weld) are white at end of test. (see below)								
									
Data Files									
Environmental Chamber Data:	130708_lvs3_norm_normISA_maxISA.csv								
FIO Vaisala Dew Point Data:	2013-07-08_8_59.csv								
FIO Alicat Data:	20130708_0846_alicat.dat								
FIO APS Data:	test_july_08_2013_1.A21								
Entries made by:	Julia Flaherty				Technical Data Review performed by:	Elizabeth Golovich			
Signature/date	On File w/ Original 7/8/2013				Signature/date	On File w/ Original 7/18/2013			

HIGH TEMPERATURE PROBE TESTING - Aerosol Penetration										
Fluorometry Data										
Run No.	AP-3			Facility	LV-S3					
Date	7/8/2013			Chamber Set Point	243°F / 9.6% RH					
Start/End Time	8:05 / 11:40			Diluter Flows	Norm, Norm ISA					
Testers	JEF / MSP			Diluter Orientation	Horiz					
Materials and Equipment Used:				Cal Due						
Turner Trilogy Fluorometer		S/N 720000895		Sartorius QS 2000 Lab Balance		S/N 60502077		6/24/2014		
Sartorius CPA224A Lab Balance		S/N 27950023		Sartorius CPA224A Lab Balance		S/N 27950023		9/29/2013		
Aerosol Wash Solution		ID AW04		Aerosol Wash Solution		ID AW04		Made on 7/5/13		
Whatman AutoVial		N/A		Whatman AutoVial		N/A		N/A		
N/A		N/A		N/A		N/A		N/A		
		Wash Solution		Fluorescence				Aerosol Penetration		
Sample	Mass (g)	1 - RFU	2 - RFU	3 - RFU	Mean	RFU/g				
Pre-Test Wash	Fittings	70.8	21.88	22.29	22.23	22.1	0.3			
	Diluter	143.0	21.08	21.70	21.81	21.5	0.2	N/A		
	Solid Std	N/A	2626.79	2626.77	2626.57	2626.7				
	Solution Blank	N/A	8.01	8.07	8.11	8.1				
First Wash	Filter	103.9	3566.43	3554.95	3569.35	3563.6	34.3			
	Fittings	59.5	561.73	561.83	559.19	560.9	9.4	0.9911		
	Diluter	153.6	58.57	61.92	61.17	60.6	0.4			
	Solid Std	N/A	2632.07	2631.40	2631.68	2631.7				
	Filter Blank	99.9	24.26	24.15	24.13	24.2	0.2			
	Solution Blank	N/A	8.15	8.09	8.13	8.1				
Second Wash	Filter	106.6	275.82	279.27	278.65	277.9	2.6			
	Fittings	61.4	198.83	198.33	198.36	198.5	3.2	0.9886		
	Diluter	152.5	25.68	26.89	27.87	26.8	0.2			
	Solid Std	N/A	2611.25	2610.83	2610.72	2610.9				
	Filter Blank	100.5	22.92	23.31	25.48	23.9	0.2			
	Solution Blank	N/A	8.75	8.69	9.03	8.8				
Third Wash	Filter	99.4	119.81	118.54	119.0	119.1	1.2			
	Fittings	61.2	78.81	79.07	78.48	78.8	1.3	0.9871		
	Diluter	147.4	16.12	16.64	16.52	16.4	0.1			
	Solid Std	N/A	2433.79	2433.33	2434.03	2433.7				
	Filter Blank	98.0	18.63	20.58	21.76	20.3	0.2			
	Solution Blank	N/A	9.52	9.89	10.2	9.9				
Notes: Blow out the diluter between washes.										
Used autovial for all of the 1st washes, and only filters for the 2nd and 3rd washes.										
/										
JF 7/8/13										
Entries made by:	Julia Flaherty			Technical Data Review performed by:	Elizabeth Golovich					
Signature/date	On File w/ Original 7/8/2013			Signature/date	On File w/ Original 7/18/2013					

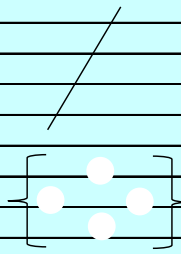
HIGH TEMPERATURE PROBE TESTING - Aerosol Penetration										
Aerosol and Dilution Data										
Run No.	AP-4				Facility	LV-S3				
Date	7/8/2013				Chamber Set Point	243°F / 9.6% RH				
Start/End Time	13:15 / 13:50				Diluter Flows	Max, Norm ISA				
Testers	JEF, MSP				Diluter Orientation	Horiz				
	Start	Finish			Materials and Equipment Used:				Cal Due	
Time	13:15	13:50			Thermotron SE-2000-4 Env Chamber S/N 42857				4/2/2014	
Chamber Temp	243	243	°F		Alicat MCR-500SLPM MFC		SN 68858	2/4/2014		
Chamber Humidity	9.6%	9.6%	RH		Alicat MCR-500SLPM-D MFC		SN 68857	4/3/2014		
Dilution flowcontroller	9.76	9.76	scfm		Vaisala MI70/HMP77B		S/N G5230040/H0320001	1/31/2014		
Dilution Dew Pt	3	8	°F		Vaisala MI70/DMP74B		S/N G5230040/H0320001	1/31/2014		
Dilution Temp	85.6	86.7	°F		Type T Thermocouples				T004 - T006, T008, T009	6/18/2014
Dilution P	15.2	15.2	psia		Mott Corp Diluter		Model 7610S-1.375-24-2-AB		N/A	
Sampling flowcontroller	10.52	10.52	scfm		Fisher Dew Point Pen		S/N 122277883		5/16/2014	
Sampling Dew Pt	47	47	°F		TSI VOAG, Model 345001		S/N 406		N/A	
Sampling Temp	98	99	°F		VOAG Aerosol Solution				ID AS01	made on 7/1/2013
Sampling P	13.2	13.2	psia		Hach OPC		S/N 1011529009		12/14/2014	
Ambient pressure	998.9	998.9	mbar		/					
Ambient humidity	32.7%	31.9%	RH							
Ambient Temp	77.9	77.8	°F		Droplet Diameter: $Dd = (6Q/πf)^{1/3}$			46.5 μm		
VOAG Frequency	48.40	48.40	kHz							
VOAG Syringe Speed	4.6	4.6	x 10 ⁻⁴ cm/s				Aerosol concentration, C	0.0142		
VOAG Dispersion Air	10	10	cc/min x 100				Aerosol density, ρ	0.8931		
VOAG Dilution Air	70	70	LPM							
					Particle Diameter: $Dp = (C+)^{1/3}Dd$			11.5 μm		
					Aerodynamic Diameter: $AD = Dp \cdot \sqrt{ρ}$			10.9 μm		
Notes:	Start heat tape, flow ~12:03. Heat tapes set to 213°F, which should correspond to ~243°F on our calibrated thermocouples.									
	Increment humidity from 0.8% to 9.6%. (0.8% to 3.0 to 6.0 to 8.0 to 9.0 to 9.6%)									
	Both water filter and oil filter on air system filling up with water; nearly full by end of test.									
	The four water indicator dots on upstream end, near weld are all white at the end of the test. (see below)									
										
	water indicator dots on upstream end of diluter. all white.									
Data Files										
Environmental Chamber Data:	130708_lvs3_norm_normISA_maxISA.csv									
FIO Vaisala Dew Point Data:	2013-07-08_8_59.csv									
FIO Alicat Data:	20130708_0846_alicat.dat									
FIO APS Data:	test_july_08_2013_1.A21									
Entries made by:	Julia Flaherty				Technical Data Review performed by:	Elizabeth Golovich				
Signature/date	On File w/ Original 7/8/2013				Signature/date	On File w/ Original 7/18/2013				

HIGH TEMPERATURE PROBE TESTING - Aerosol Penetration									
Fluorometry Data									
Run No.	AP-4			Facility	LV-S3				
Date	7/8/2013			Chamber Set Point	243°F / 9.6% RH				
Start/End Time	15:10 / 16:05			Diluter Flows	Max, Norm ISA				
Testers	JEF / MSP			Diluter Orientation	Horiz				
Materials and Equipment Used:				Cal Due					
Turner Trilogy Fluorometer		S/N 720000895		N/A					
Sartorius QS 2000 Lab Balance		S/N 60502077		6/24/2014					
Sartorius CPA224A Lab Balance		S/N 27950023		9/29/2013					
Aerosol Wash Solution		ID AW04		Made on 7/5/13					
Whatman AutoVial		N/A							
N/A									
	Wash Solution		Fluorescence					Aerosol Penetration	
	Sample	Mass (g)	1 - RFU	2 - RFU	3 - RFU	Mean	RFU/g		
Pre-Test Wash	Fittings	61.2	78.81	79.07	78.48	78.8	1.3	N/A	
	Diluter	147.4	16.12	16.64	16.52	16.4	0.1		
	Solid Std	N/A	2433.79	2433.33	2434.03	2433.7			
	Solution Blank	N/A	9.52	9.89	10.20	9.9			
First Wash	Filter	88.0	4467.85	4482.92	4497.07	4482.6	50.9	0.9913	
	Fittings	45.3	619.06	620.90	619.45	619.8	13.7		
	Diluter	149.1	83.46	85.74	85.64	84.9	0.6		
	Solid Std	N/A	2475.63	2476.32	2476.03	2476.0			
	Filter Blank	89.4	16.09	16.76	16.69	16.5	0.2		
	Solution Blank	N/A	10.81	10.81	10.78	10.8			
Second Wash	Filter	91.6	133.93	134.09	133.85	134.0	1.5	0.9894	
	Fittings	48.7	83.13	83.45	83.66	83.4	1.7		
	Diluter	119.4	18.83	18.2	18.55	18.5	0.2		
	Solid Std	N/A	2569.88	2569.65	2569.76	2569.8			
	Filter Blank	90.7	14.48	13.58	14.00	14.0	0.2		
	Solution Blank	N/A	10.75	10.67	10.87	10.8			
Third Wash	Filter	75.5	84.96	85.49	85.87	85.4	1.1	0.9879	
	Fittings	59.0	133.07	127.31	130.59	130.3	2.2		
	Diluter	103.6	14.88	15.57	15.03	15.2	0.1		
	Solid Std	N/A	2633.84	2633.11	2633.19	2633.4			
	Filter Blank	77.5	12.54	12.9	13.22	12.9	0.2		
	Solution Blank	N/A	11.57	11.37	11.47	11.5			
Notes: Use the 3rd wash from AP-3 as pre-wash for this test (AP-4).									
Use autovial for all first wash, and only filters for second and third wash.									
Don't blow out diluter between washes.									
Third wash for fittings looks odd... Run another wash.									
65.7g wash for fittings #4: 69.53, 70.53, 72.05 RFU.									
/									
JF 7/8/13									
Entries made by:		Julia Flaherty			Technical Data Review performed by:		Elizabeth Golovich		
Signature/date		On File w/ Original 7/8/2013			Signature/date		On File w/ Original 7/18/2013		

HIGH TEMPERATURE PROBE TESTING - Aerosol Penetration						
Aerosol and Dilution Data						
Run No.	AP-5			Facility	LV-S3	
Date	7/9/2013			Chamber Set Point	243°F / 9.6% RH	
Start/End Time	14:36 / 15:20			Diluter Flows	Max, Norm ISA	
Testers	JEF			Diluter Orientation	Vert	
	Start	Finish		Materials and Equipment Used:		Cal Due
Time	14:36	15:20		Thermotron SE-2000-4 Env Chamber S/N 42857		4/2/2014
Chamber Temp	243	243	°F	Alicat MCR-500SLPM MFC SN 68858		2/4/2014
Chamber Humidity	9.6%	9.6%	RH	Alicat MCR-500SLPM-D MFC SN 68857		4/3/2014
Dilution flowcontroller	9.76	9.76	scfm	Vaisala MI70/HMP77B S/N G5230040/H0320001		1/31/2014
Dilution Dew Pt	3	16	°F	Vaisala MI70/DMP74B S/N G5230040/H0320001		1/31/2014
Dilution Temp	87.2	89.0	°F	Type T Thermocouples T004 - T006, T008, T009		6/18/2014
Dilution P	15.4	15.4	psia	Mott Corp Diluter Model 7610S-1.375-24-2-AB		N/A
Sampling flowcontroller	10.52	10.52	scfm	Fisher Dew Point Pen S/N 122277883		5/16/2014
Sampling Dew Pt	48	49	°F	TSI VOAG, Model 345001 S/N 406		N/A
Sampling Temp	98	100	°F	VOAG Aerosol Solution ID AS01 made on 7/1/2013		
Sampling P	12.9	12.9	psia	Hach OPC S/N 1011529009		12/14/2014
Ambient pressure	1000	999.7	mbar	TSI APS S/N 70907086		N/A
Ambient humidity	27.2%	26.5%	RH			
Ambient Temp	79.1	78.8	°F	Droplet Diameter: $D_d = (6Q/πf)^{1/3}$		46.5 μm
VOAG Frequency	48.38	48.38	kHz			
VOAG Syringe Speed	4.6	4.6	x 10 ⁻⁴ cm/s	Aerosol concentration, C		0.0142
VOAG Dispersion Air	10	10	cc/min x 100	Aerosol density, ρ		0.8931
VOAG Dilution Air	70	70	LPM	Particle Diameter: $D_p = (C+I)^{1/3}D_d$		11.5 μm
				Aerodynamic Diameter: $AD = D_p \cdot \text{SQRT}(\rho/1)$		10.9 μm
Notes: Turned on heat tapes at ~13:30. Set to 213°F, which should correspond to ~243°F on our calibrated thermocouples.						
Forgot to apply water indicator dots on the diluter. It's 13:40, but the tubing is already hot, so we'll skip this one. (The diluter is covered in heat tape, so dis-assembly is not trivial.)						
Incremented the humidity from 0.8% to 9.6% (from 0.8 to 3.0 to 6.0 to 8.0 to 9.0 to 9.6%).						
The water filter filled up during test. The oil filter is about half full. Fresh desiccant was added to both systems before this test. Ran the lower system for this test.						
<i>Data Files</i>						
Environmental Chamber Data: 130709_lvs3_norm_maxISA.csv						
FIO Vaisala Dew Point Data: 2013-07-09_15_09.csv						
FIO Alicat Data: 20130709_1331_alicat.dat						
FIO APS Data: test_july_09_2013_1.A21						
Entries made by:	Julia Flaherty			Technical Data Review performed by:	Elizabeth Golovich	
Signature/date	On File w/ Original 7/9/2013			Signature/date	On File w/ Original 7/18/2013	

HIGH TEMPERATURE PROBE TESTING - Aerosol Penetration								
Fluorometry Data								
Run No.	AP-5			Facility	LV-S3			
Date	7/9/2013			Chamber Set Point	243°F / 9.6% RH			
Start/End Time	12:54 / 16:50			Diluter Flows	Max, Norm ISA			
Testers	JEF			Diluter Orientation	Vert			
Materials and Equipment Used:				Cal Due				
Turner Trilogy Fluorometer		S/N 720000895		N/A				
Sartorius QS 2000 Lab Balance		S/N 60502077		6/24/2014				
Sartorius CPA 224A Lab Balance		S/N 27950023		9/29/2013				
Aerosol Wash Solution		ID AW05		Made on 7/8/13				
Whatman AutoVial		N/A						
N/A								
	Wash Solution		Fluorescence				Aerosol Penetration	
	Sample	Mass (g)	1 - RFU	2 - RFU	3 - RFU	Mean		RFU/g
Pre-Test Wash	Fittings	75.2	32.27	32.18	32.46	32.3	0.4	N/A
	Diluter	130.9	17.22	17.39	17.91	17.5	0.1	
	Solid Std	N/A	2643.89	2643.05	2642.81	2643.3		
	Solution Blank	N/A	8.25	8.28	8.33	8.3		
First Wash	Filter	98.0	1147.86	1145.08	1144.64	1145.9	11.7	0.9966
	Fittings	102.7	4471.18	4471.54	4475.78	4472.8	43.6	
	Diluter	148.0	27.84	28.04	27.62	27.8	0.2	
	Solid Std	N/A	2646.23	2645.75	2645.61	2645.9		
	Filter Blank	102.3	14.58	16.19	16.45	15.7	0.2	
	Solution Blank	N/A	8.49	8.26	8.58	8.4		
Second Wash	Filter	100.0	71.99	73.20	72.21	72.5	0.7	0.9940
	Fittings	120.4	119.87	119.89	119.55	119.8	1.0	
	Diluter	148.6	22.75	22.60	23.46	22.9	0.2	
	Solid Std	N/A	2645.13	2644.31	2644.86	2644.8		
	Filter Blank	104.1	14.24	13.50	13.58	13.8	0.1	
	Solution Blank	N/A	10.48	10.71	10.74	10.6		
Third Wash	Filter	97.7	28.65	29.49	29.44	29.2	0.3	0.9924
	Fittings	120.5	27.04	28.54	31.91	29.2	0.2	
	Diluter	143.9	14.16	14.61	14.23	14.3	0.1	
	Solid Std	N/A	2634.78	2636.78	2636.10	2635.9		
	Filter Blank	98.1	13.56	14.34	14.46	14.1	0.1	
	Solution Blank	N/A	10.90	10.96	10.83	10.9		
Notes: Autovial used for everything on first wash, then only filters on second and third washes.								
Did not blow out diluter between washes.								
/								
Entries made by:		Julia Flaherty		Technical Data Review performed by:		Elizabeth Golovich		
Signature/date		On File w/ Original 7/9/2013		Signature/date On File w/ Original		7/18/2013		

HIGH TEMPERATURE PROBE TESTING - Aerosol Penetration							
Aerosol and Dilution Data							
Run No.	AP-6			Facility	LV-S3		
Date	7/11/2013			Chamber Set Point	243°F / 9.6% RH		
Start/End Time	14:30 / 15:10			Diluter Flows	Max, Norm ISA		
Testers	JEF, JAG, MSP			Diluter Orientation	Vert		
	Start	Finish		Materials and Equipment Used:			Cal Due
Time	14:30	15:10		Thermotron SE-2000-4 Env Chamber S/N 42857			4/2/2014
Chamber Temp	243	243	°F	Alicat MCR-500SLPM MFC SN 68858			2/4/2014
Chamber Humidity	9.6%	9.6%	RH	Alicat MCR-500SLPM-D MFC SN 68857			4/3/2014
Dilution flowcontroller	9.76	9.76	scfm	Vaisala MI70/HMP77B S/N G5230040/H0320001			1/31/2014
Dilution Dew Pt	-17	-6	°F	Vaisala MI70/DMP74B S/N G5230040/H0320001			1/31/2014
Dilution Temp	87.7	87.2	°F	Type T Thermocouples T004 - T006, T008, T009			6/18/2014
Dilution P	15.3	15.3	psia	Mott Corp Diluter Model 7610S-1.375-24-2-AB			N/A
Sampling flowcontroller	10.52	10.52	scfm	Fisher Dew Point Pen S/N 122277883			5/16/2014
Sampling Dew Pt	45	47	°F	TSI VOAG, Model 345001 S/N 406			N/A
Sampling Temp	101	101	°F	VOAG Aerosol Solution ID AS01 made on 7/1/2013			
Sampling P	12.8	12.8	psia	Hach OPC S/N 1011529009			12/14/2014
Ambient pressure	995.3	995.0	mbar	TSI APS S/N 70907086			N/A
Ambient humidity	25.4%	28.0%	RH				
Ambient Temp	81.6	79.9	°F	Droplet Diameter: $D_d = (6Q/\pi f)^{1/3}$			46.5 μm
VOAG Frequency	48.49	48.51	kHz				
VOAG Syringe Speed	4.6	4.6	$\times 10^{-4}$ cm/s	Aerosol concentration, C			0.0142
VOAG Dispersion Air	10	10	cc/min x 100	Aerosol density, ρ			0.8931
VOAG Dilution Air	70	70	LPM				
				Particle Diameter: $D_p = (C+)^{1/3} D_d$			11.5 μm
				Aerodynamic Diameter: $A_D = D_p \cdot \text{SQRT}(\rho/1)$			10.9 μm
Notes: AP-6 is a repeat of AP-5.							
Turned on heat tapes at ~11:30. Set to 213°F, which should correspond to ~243°F on our calibrated thermocouples.							
Increment humidity from 0.8% to 9.6% (from 0.8 to 3.0 to 6.0 to 8.0 to 9.0 to 9.6%).							
John coated a few glass slides with Novec 1720 oleophobic coating. We placed 2 in the chamber at around 11:40, which dropped the temperature for a few minutes. #1 was just in front of probe, #2 was behind.							
Noticed that the thermocouples for heat tape #2 had fallen off before I wrapped the heat tape, and the thermocouple broke.							
Replaced thermocouple and re-wrapped heat tape; back on track a little after 1 pm.							
All 3M water indicator dots were white at end of test.							
Data Files							
Environmental Chamber Data:	130711_lvs3_norm_maxISA.csv						
FIO Vaisala Dew Point Data:	2013-07-11 12_04.csv						
FIO Alicat Data:	20130711_1148_alicat.dat						
FIO APS Data:	test_july_11_2013_1.A21						
Entries made by:	Julia Flaherty			Technical Data Review performed by:	Elizabeth Golovich		
Signature/date	On File w/ Original 7/11/2013			Signature/date	On File w/ Original 7/18/2013		

HIGH TEMPERATURE PROBE TESTING - Aerosol Penetration								
Fluorometry Data								
Run No.	AP-6			Facility	LV-S3			
Date	7/11/2013			Chamber Set Point	243°F / 9.6% RH			
Start/End Time	8:35 / 16:30			Diluter Flows	Max, Norm ISA			
Testers	JEF, JAG, MSP			Diluter Orientation	Vert			
Materials and Equipment Used:					Cal Due			
Turner Trilogy Fluorometer		S/N 720000895		N/A				
Sartorius QS 2000 Lab Balance		S/N 60502077		6/24/2014				
Sartorius CPA 224A Lab Balance		S/N 27950023		9/29/2013				
Aerosol Wash Solution		ID AW06		Made on 7/9/13				
Whatman AutoVial		N/A						
N/A								
	Wash Solution			Fluorescence				Aerosol
	Sample	Mass (g)		1 - RFU	2 - RFU	3 - RFU	Mean	RFU/g Penetration
Pre-Test Wash	Fittings	104.7		24.38	24.92	24.91	24.7	0.2
	Diluter	148.1		17.81	17.68	17.80	17.8	0.1
	Solid Std	N/A		2626.75	2628.35	2627.83	2627.6	N/A
	Solution Blank	N/A		9.35	9.88	9.35	9.5	
First Wash	Filter	99.2		2028.65	2019.65	2027.52	2025.3	20.4
	Fittings	100.4		3411.13	3413.94	3406.41	3410.5	34.0
	Diluter	151.1		61.75	62.02	61.92	61.9	0.4
	Solid Std	N/A		2643.80	2644.06	2644.85	2644.2	
	Filter Blank	102.9		17.33	17.98	17.55	17.6	0.2
	Solution Blank	N/A		12.27	12.78	13.40	12.8	
Second Wash	Filter	95.1		94.19	93.39	93.17	93.6	1.0
	Fittings	93.2		219.99	217.95	219.53	219.2	2.4
	Diluter	124.2		15.78	17.63	16.39	16.6	0.1
	Solid Std	N/A		2640.95	2641.01	2641.65	2641.2	
	Filter Blank	101.3		14.55	14.77	14.86	14.7	0.1
	Solution Blank	N/A		13.16	13.17	13.11	13.1	
Third Wash	Filter	86.4		44.36	45.23	44.96	44.9	0.5
	Fittings	77.0		61.39	61.16	61.84	61.5	0.8
	Diluter	128.2		13.50	13.37	13.29	13.4	0.1
	Solid Std	N/A		2648.82	2648.39	2647.93	2648.4	
	Filter Blank	85.8		13.74	13.98	13.86	13.9	0.2
	Solution Blank	N/A		13.93	13.72	13.89	13.8	
Notes: Used autovial used for all of the first washes, and only the filters on second and third washes.								
Did not blow out diluter between washes.								
Shook the filter paper (a lot) for the first wash, so we had lots of pieces for the second and third wash.								
/								
Entries made by:	Julia Flaherty			Technical Data Review performed by:			Elizabeth Golovich	
Signature/date	On File w/ Original 7/11/2013			Signature/date On File w/ Original			7/18/2013	

HIGH TEMPERATURE PROBE TESTING - Aerosol Penetration			
VOAG Aerosol Solution Data			
Date	7/1/2013	Facility	LV-S3
Time	17:00	Testers	JEF
ID	AS01		
Materials and Equipment Used:			Cal Due
Sartorius QS 2000 Lab Balance	S/N 60502077		6/24/2014
Sartorius CPA 224A Lab Balance	S/N 27950023		9/29/2013
3 mL disposable pipettes			
Turner Designs Fluorescein	Lot # A216E236		N/A
Isopropyl Alcohol, 99.9%	Lot 115223		N/A (CMS 333044)
Oleic Acid, Technical Grade, 90%	Lot # MKBH5625V		N/A
Target Mix, by volume:		Density, g/mL	
Oleic Acid	1.0		0.89
Fluorescein Solution	0.02		1.28
Isopropyl Alcohol	70		0.79
Target Mix, by mass:		mass in 400g	
Oleic Acid	0.89		6.3328
Fluorescein Solution	0.0256		0.1822
Isopropyl Alcohol	55.3		393.4851
<i>Total:</i>	<i>56.2156</i>		<i>400.0000</i>
Actual Mix, by mass:		by volume	in 71.02 parts
Oleic Acid	6.3364	7.12	1.00
Fluorescein Solution	0.184	0.14	0.02
Isopropyl Alcohol	393.5	498.10	70.00
<i>Total:</i>	<i>400.0204</i>	<i>505.36</i>	<i>71.02</i>
Volumetric Concentration of nonvolatile solute, C		0.0142	
Aerosol Density, ρ		0.8931	
Notes: 1 L amber Nalgene jar is ~83g.			
Shake up the oleic acid and fluorescein bottles before use.			
Entries made by: Julia Flaherty		Technical Data Review performed by: Elizabeth Golovich	
Signature/date On File w/ Original 7/1/2013		Signature/date On File w/ Original 7/18/2013	

HIGH TEMPERATURE PROBE TESTING - Aerosol Penetration

Aerosol Wash Solution Data

Date	7/1/2013	Facility	LV-S3
Time	10:55 - 11:20	Testers	JEF
ID	AW01		

Materials and Equipment Used:		Cal Due
Sartorius QS 2000 Lab Balance	S/N 60502077	6/24/2014
Sartorius CPA 224A Lab Balance	S/N 27950023	9/29/2013
WWR 2000 mL graduated cylinder, B, Tol +/- 10.0		N/A
3 mL disposable pipettes		N/A
Whatman pH indicator paper, Type CF (Cat. No. 2614991)		N/A
Sigma Aldrich IPA	Batch #68996MK	N/A (CMS: 307609)
Sigma Aldrich IPA	Batch #68996MK	N/A (CMS: 307610)
N/A		

	Volume (mL)	Mass (g)	
Deionized water	1000	983.9	
Isopropyl alcohol	1000	809.0	
# of NH4OH drops:	9		
pH:	8		Target pH = 8.0-10.0

Notes: Starting pH ~ 6.5.
 First 3 drops of NH4OH may have been smaller than the others.
 #307609 is empty.

/ JF 7/1/2013

Entries made by:	Julia Flaherty	Technical Data Review performed by:	Elizabeth Golovich
Signature/date	On File w/ Orig. 7/1/2013	Signature/date	On File w/ Original 7/18/2013

HIGH TEMPERATURE PROBE TESTING - Aerosol Penetration

Aerosol Wash Solution Data

Date	7/2/2013	Facility	LV-S3
Time	10:35 - 10:55	Testers	JEF
ID	AW02		

Materials and Equipment Used:		Cal Due
Sartorius QS 2000 Lab Balance	S/N 60502077	6/24/2014
Sartorius CPA 224A Lab Balance	S/N 27950023	9/29/2013
VWR 2000 mL graduated cylinder, B, Tol +/- 10.0		N/A
3 mL disposable pipettes		N/A
Whatman pH indicator paper, Type CF (Cat. No. 2614991)		N/A
Wash Solution AW01		Made on 7/1/2013
Sigma Aldrich IPA	Batch # 68996MK	N/A (CMS: 307610)
Sigma Aldrich IPA	Batch # 68996MK	N/A (CMS: 307608)

	Volume (mL)	Mass (g)
Deionized water	1000	987
Isopropyl alcohol	1000	804.5

of NH4OH drops: 9

pH: 8 Target pH = 8.0-10.0

Notes: CMS # 307610 is empty.

Combine the 2000 mL of this mixture with yesterday's AW01 for a new AW02. There's ~1L of AW01 left, and that's not enough for a test's worth of washing.

Starting pH ~7.0 to 7.5.

JF 7/2/2013

Entries made by:	Julia Flaherty	Technical Data Review performed by:	Elizabeth Golovich
Signature/date	On File w/ Orig. 7/2/2013	Signature/date	On File w/ Original 7/18/2013

HIGH TEMPERATURE PROBE TESTING - Aerosol Penetration

Aerosol Wash Solution Data

Date **7/3/2013**

Facility **LV-S3**

Time **17:25 - 17:42**

Testers **JEF**

ID **AW03**

Materials and Equipment Used:

Cal Due

Sartorius QS 2000 Lab Balance	S/N 60502077	6/24/2014
Sartorius CPA 224A Lab Balance	S/N 27950023	9/29/2013
WWR 2000 mL graduated cylinder, B, Tol +/- 10.0		N/A
3 mL disposable pipettes		N/A
Whatman pH indicator paper, Type CF (Cat. No. 2614991)		N/A
Wash Solution AW02		Made on 7/2/2013
Fisher Scientific IPA	Lot 115223	N/A (CMS: 333044)
Fisher Scientific IPA	Lot 115223	N/A (CMS: 358166)
Fisher Scientific IPA	Lot 115223	N/A (CMS: 333043)

	Volume (mL)	Mass (g)
Deionized water	1000	984.9
Isopropyl alcohol	1000	805.7

of NH4OH drops: **9**

pH: **8**

Target pH = 8.0-10.0

Notes: CMS # 333044 & 358166 are empty.

Combine the 2000 mL of this mixture w/ AW02.

Starting pH ~7.0 - 7.5.

/

JF 7/3/2013

Entries made by:	Julia Flaherty	Technical Data Review performed by:	Elizabeth Golovich
Signature/date	On File w/ Orig. 7/3/2013	Signature/date	On File w/ Original 7/18/2013

HIGH TEMPERATURE PROBE TESTING - Aerosol Penetration

Aerosol Wash Solution Data

Date **7/5/2013**

Facility **LV-S3**

Time **16:17 - 16:40**

Testers **JEF**

ID **AW04**

Materials and Equipment Used:

Cal Due

Sartorius QS 2000 Lab Balance	S/N 60502077	6/24/2014
Sartorius CPA 224A Lab Balance	S/N 27950023	9/29/2013
WWR 2000 mL graduated cylinder, B, Tol +/- 10.0		N/A
3 mL disposable pipettes		N/A
Whatman pH indicator paper, Type CF (Cat. No. 2614991)		N/A
Wash Solution AW03		Made on 7/3/2013
Fisher Scientific IPA	Lot 115223	N/A (CMS: 333043)
Fisher Scientific IPA	Lot 127641	N/A (CMS: 392783)

	Volume (mL)	Mass (g)
Deionized water	600	588.8
Isopropyl alcohol	600	487.9

of NH4OH drops: **6**

pH: **8**

Target pH = 8.0-10.0

Notes:

/

JF 7/3/2013

Entries made by: Julia Flaherty	Technical Data Review performed by: Elizabeth Golovich
Signature/date <i>On File w/ Orig.</i> 7/5/2013	Signature/date <i>On File w/ Original</i> 7/18/2013

HIGH TEMPERATURE PROBE TESTING - Aerosol Penetration

Aerosol Wash Solution Data

Date	7/8/2013	Facility	LV-S3
Time	6:20	Testers	JEF
ID	AW05		

Materials and Equipment Used:		Cal Due
Sartorius QS 2000 Lab Balance	S/N 60502077	6/24/2014
Sartorius CPA 224A Lab Balance	S/N 27950023	9/29/2013
WWR 2000 mL graduated cylinder, B, Tol +/- 10.0		N/A
3 mL disposable pipettes		N/A
Whatman pH indicator paper, Type CF (Cat. No. 2614991)		N/A
Wash Solution AW04		Made on 7/5/2013
Fisher Scientific IPA	Lot 127641	N/A (CMS: 392783)
Fisher Scientific IPA	Lot 127641	N/A (CMS: 392782)

	Volume (mL)	Mass (g)
Deionized water	1000	988.7
Isopropyl alcohol	1000	802.2

of NH4OH drops: 9

pH: 8.0 Target pH = 8.0-10.0

Notes: Very small amount of AW04 left (<500 mL).

Combine this mix with the remaining AW04.

CMS #392783 is empty.

Entries made by:	Julia Flaherty	Technical Data Review performed by:	Elizabeth Golovich
Signature/date	On File w/ Orig. 7/8/2013	Signature/date	On File w/ Original 7/18/2013

HIGH TEMPERATURE PROBE TESTING - Aerosol Penetration

Aerosol Wash Solution Data

Date	7/9/2013	Facility	LV-S3
Time	17:40 - 18:00	Testers	JEF
ID	AW06		

Materials and Equipment Used:		Cal Due
Sartorius QS 2000 Lab Balance	S/N 60502077	6/24/2014
Sartorius CPA 224A Lab Balance	S/N 27950023	9/29/2013
WWR 2000 mL graduated cylinder, B, Tol +/- 10.0		N/A
3 mL disposable pipettes		N/A
Whatman pH indicator paper, Type CF (Cat. No. 2614991)		N/A
Wash Solution AW05		Made on 7/8/2013
Fisher Scientific IPA	Lot 127641	N/A (CMS: 392782)
Fisher Scientific IPA	Lot 127641	N/A (CMS: 392781)

	Volume (mL)	Mass (g)
Deionized water	1400	1387.9
Isopropyl alcohol	1400	1085.4

of NH4OH drops: 13

pH: 8.0 Target pH = 8.0-10.0

Notes: Very small amount of AW05 left (<500 mL).
 Combine this mix with the remaining AW05.
 CMS #392782 is empty.

/

Entries made by: Julia Flaherty Signature/date On File w/ Orig. 7/9/2013	Technical Data Review performed by: Elizabeth Golovich Signature/date On File w/ Original 7/18/2013
--	---

Appendix B

HV-S3 Test Data Sheets

B.1 HV-S3 Temperature and Humidity Data Sheets

TDP-WTPSP-636
 TH p# of 17
 5
 11/14/13

HIGH TEMPERATURE PROBE TESTING - Temperature / Humidity Only

Run No. TH-1
 Date 7/29/13
 Start/End Time 9:40 / 10:45
 Testers JEF

Facility / Condition HV-S3 Min
 Chamber Set Point 261°F / 2.3% RH
 Diluter Orientation Horiz or Vert

	Start	Finish	
Time	9:40	10:45	
Chamber Temp	261.7	261.0	°F
Chamber Humidity	2.3	2.3	RH
Dilution flowcontroller	2.39	2.39	scfm
Dilution Dew Pt	-4	-4	°F
Dilution Temp	78	76	°F
Dilution P	14.6	14.6	psia
Sampling flowcontroller	3.31	3.31	scfm
Sampling Dew Pt	71	71	°F
Sampling Temp	89	90	°F
Sampling P	13.9	13.90	psia
Ambient pressure	997.2	997.0	mbar
Ambient humidity	28%	30%	RH
Ambient Temp	76.5	75.4	°F

Instruments Used:	Cal Due
✓ Thermotron SE-2000-4 Env Chamber S/N 42857	4/2/2014
✓ Type T Thermocouples T001-T006, T009, T008	6/18/2014
✓ Alicat MCR-500SLPM MFC SN 68858	2/4/2014
✓ Alicat MCR-500SLPM-D MFC SN 68857	4/3/2014
✓ Vaisala MI70/HMP77B S/N G5230040/H0320001	1/31/2014
✓ Vaisala MI70/DMP74B S/N G5230040/H0320001	1/31/2014
✓ Mott Corp Diluter 18" OAL Model 7610S-1.375-24-2-AB	N/A
✓ Fisher Dew Point Pen S/N 122277883	5/16/2014
N/A	

Notes: Programmed chamber to start at 6am at 261°F and 0.5% RH. Won't go quite that low. Came in at 0.8% RH, which is ~63°F dp. Okay with fairly warm lab temperature. Set heat tape set point to 227°F, which is around 255°F on the calibrated thermocouple. Heat tape turned on ~8:25. Mass flow controllers turned on ~8:45. Increase humidity in a few steps: 1%, 1.5%, 2%, 2.3%. At end of test, used borescope to check color of 3M dots. All appear white. Bottom desiccant used for test.

JEF 7/29/13

Data Files
 Environmental Chamber Data: 130729-hvs3-min-lvs2-norm.csv
 Vaisala Dew Point Data (FIO): 2013-07-29 8.59.csv
 Alicat Data (FIO): 20130729-0843.alicat.dat

Entries made by: <u>JULIA FLAHERTY</u> Signature/date: <u>[Signature] 7/29/13</u>	Technical Data Review performed by: Signature/date: <u>[Signature] 11/11/13</u>
--	--

TH P# of 17
6
JEF 11/14/13

HIGH TEMPERATURE PROBE TESTING - Temperature / Humidity Only

Run No. TH- 2
Date 7/30/13
Start/End Time 10:05 / 11:05
Testers JEF, JAG

Facility / Condition HV-S3 Norm
Chamber Set Point 313°F / 1.7% RH
Diluter Orientation Horiz or Vert

	Start	Finish	
Time	10:05	11:05	
Chamber Temp	313	313	°F
Chamber Humidity	1.7%	1.7	RH
Dilution flowcontroller	4.07	4.07	scfm
Dilution Dew Pt	-20	-17	°F
Dilution Temp	78	79	°F
Dilution P	14.8	14.8	psia
Sampling flowcontroller	4.88	4.88	scfm
Sampling Dew Pt	62	63	°F
Sampling Temp	92	93	°F
Sampling P	14.5	14.5	psia
Ambient pressure	1001	1002	mbar
Ambient humidity	28	28	RH
Ambient Temp	77.5	78.5	°F

Instruments Used:	Cal Due
Theratron SE-2000-4 Env Chamber S/N 42857	4/2/2014
Type T Thermocouples T001-T006, T009, T008	6/18/2014
Alicat MCR-500SLPM MFC SN 68858	2/4/2014
Alicat MCR-500SLPM-D MFC SN 68857	4/3/2014
Vaisala MI70/HMP77B S/N G5230040/H0320001	1/31/2014
Vaisala MI70/DMP74B S/N G5230040/H0320001	1/31/2014
Mott Corp Diluter 28" OAL Model 7610S-1.375-24-2-AB	N/A
Fisher Dew Point Pen S/N 122277883	5/16/2014
N/A	

Notes: Setpoint was 313°F and 0.3% RH, but at 8am, the chamber conditions were 267°F and 0.8% RH. (64°F dp). Turn on heat tape at around 8:10 am. Set point = 269°F, which should be around 313°F for the calibrated thermocouple. Turn on mass flow controllers at around 8:17. Inspected interior w/ borescope. All visible clots appear white, some of the green marker is visible. Apparently no condensation.

JEF 7/30/13

Data Files
Environmental Chamber Data: 130730-hvs3-norm-lvs2-max.csv
Vaisala Dew Point Data (FIO): 2013-07-30 9-06.csv
Alicat Data (FIO): 20130730-0815-alicat.dat

Entries made by: <u>JULIA FLAHERTY</u> Signature/date: <u>Jef Flaherty</u> 7/30/13	Technical Data Review performed by: Signature/date: <u>Elizabeth Galarch</u> 11/14/13
---	--

HIGH TEMPERATURE PROBE TESTING - Temperature / Humidity Only

TH p 6 of 17
7
7/11/13

Run No. TH-3
Date 7/30/13
Start/End Time 11:45/12:45
Testers JEF

Facility / Condition HV-S3 NORM
Chamber Set Point 313°F / 1.7% RH
Diluter Orientation Horiz or Vert

	Start	Finish	
Time	11:45	12:45	
Chamber Temp	312	313	°F
Chamber Humidity	1.7	1.7	RH
Dilution flowcontroller	7.63	7.63	scfm
Dilution Dew Pt	-15	-7	°F
Dilution Temp	82	84	°F
Dilution P	15.0	15.0	psia
Sampling flowcontroller	8.34	8.34	scfm
Sampling Dew Pt	44	45	°F
Sampling Temp	90	92	°F
Sampling P	13.6	13.6	psia
Ambient pressure	1001	1001	mbar
Ambient humidity	27%	26%	RH
Ambient Temp	80.8	81.0	°F

Instruments Used:	Cal Due
Thermotron SE-2000-4 Env Chamber S/N 42857	4/2/2014
Type T Thermocouples T001 - T006, T009, T008	6/18/2014
Alicat MCR-500SLPM MFC SN 68858	2/4/2014
Alicat MCR-500SLPM-D MFC SN 68857	4/3/2014
Vaisala MI70/HMP77B S/N G5230040/H0320001	1/31/2014
Vaisala MI70/DMP74B S/N G5230040/H0320001	1/31/2014
Mott Corp Diluter 2 nd OAL Model 7610S-1.375-24-2-AB	N/A
Fisher Dew Point Pen S/N 122277883	5/16/2014
N/A	

Notes: Run this test directly after TH-2, another HV-S3 norm case. Both tests use the ~~top~~ desiccant. - bottom (7/30/13)
Installed new filter paper (correctly) for this test.
Heat tape set to 269°F. Calibrated thermocouples read this at around 300°F.
Inspected interior with borescope. All visible dots appear white, some of the green marker is visible.
Apparently no condensation.

JEF. 7/30/13

Data Files
Environmental Chamber Data: 130730-hvs3-norm-1vs2-max.csv
Vaisala Dew Point Data (FIO): 2013-07-30 9.06.csv
Alicat Data (FIO): 20130730-0815-alicat.dat

Entries made by: JULIA FLAHERTY
Signature/date: *[Signature]* 7/30/13
Technical Data Review performed by:
Signature/date: *[Signature]* 7/11/13

TH p7 of 17
8
8/11/13

HIGH TEMPERATURE PROBE TESTING - Temperature / Humidity Only

Run No. TH-4
Date 8/11/13
Start/End Time 10:00 / 11:00
Testers JEF

Facility / Condition HV-S3 Max
Chamber Set Point 365°F / 1.5% RH
Diluter Orientation Horiz or Vert

	Start	Finish	
Time	10:00	11:00	
Chamber Temp	366	365	°F
Chamber Humidity	0.9	0.8	RH
Dilution flowcontroller	7.42	7.42	scfm
Dilution Dew Pt	-8	4	°F
Dilution Temp	72	75	°F
Dilution P	15.0	15.0	psia
Sampling flowcontroller	8.13	8.13	scfm
Sampling Dew Pt	32	24	°F
Sampling Temp	84	86	°F
Sampling P	13.5	13.5	psia
Ambient pressure	997.2	997.4	mbar
Ambient humidity	35%	45%	RH
Ambient Temp	71.7	75.0	°F

Instruments Used:	Cal Due
Thermotron SE-2000-4 Env Chamber S/N 42857	4/2/2014
Type T Thermocouples Tool-Tool6, Tool9, Tool8	6/18/2014
Alicat MCR-500SLPM MFC SN 68858	2/4/2014
Alicat MCR-500SLPM-D MFC SN 68857	4/3/2014
Vaisala MI70/HMP77B S/N G5230040/H0320001	1/31/2014
Vaisala MI70/DMP74B S/N G5230040/H0320001	1/31/2014
Mott Corp Diluter 28 ⁴ 0AL Model 7610S-1.375-24-2-AB	N/A
Fisher Dew Point Pen S/N 122277883	5/16/2014
N/A	

Notes: Programmed chamber to start at 6am at 365°F and 0.5% RH. ThermAlarm tripped at 7:19am, so the chamber shut off. ThermAlarm was set at 376°F. At 8am, chamber had cooled to 320°F. Manual run set to 365°F & 0.5% RH. Turned on heat tape ~8:20, set point = 310°F should be near 365°F on calibrated thermocouples. With chamber temp at 350°F, noticed that humidity panel says "Temp out of range" and throttle is 0%. Set temperature at 328°F to get rid of that msg. Chamber was at 328°F / 3.0% RH ~9:00, then set to 365°F / 1.5% RH (but probably no humidity control.) Despite my attempt to retain some moisture from a lower temperature, it appears that ~0.8% RH is where the chamber wants to be... this won't be conservative for moisture... Used borescope to examine interior. Appears that no condensation was formed.

Data Files
Environmental Chamber Data: 130801_hvs3-max.csv
Vaisala Dew Point Data (FIO): 2013-08-01 8-47.csv
Alicat Data (FIO): 20130801-0847-alicat.dat

Entries made by: JULIA FLAHERTY
Signature/date: [Signature] 8/11/13
Technical Data Review performed by: Chebeth G. [Signature]
Signature/date: [Signature] 11/11/13

TH p8 of 17
9
8/11/13

HIGH TEMPERATURE PROBE TESTING - Temperature / Humidity Only

Run No. TH-5
Date 8/11/13
Start/End Time 14:17/15:17
Testers JEF

Facility / Condition HV-S3 Max
Chamber Set Point 365°F / 1.5% RH*
Diluter Orientation Horiz or Vert

	Start	Finish	
Time	14:17	15:17	
Chamber Temp	365	365	°F
Chamber Humidity	2.5%	1.2%	RH
Dilution flowcontroller	7.63	7.63	scfm
Dilution Dew Pt	8-3	6	°F
Dilution Temp	79	79	°F
Dilution P	15.0	15.0	psia
Sampling flowcontroller	8.34	8.34	scfm
Sampling Dew Pt	59	46	°F
Sampling Temp	88	89	°F
Sampling P	13.5	13.4	psia
Ambient pressure	996.6	996.9	mbar
Ambient humidity	39	34	RH
Ambient Temp	76.3	76.1	°F

Instruments Used:	Cal Due
Thermotron SE-2000-4 Env Chamber S/N 42857	4/2/2014
Type T Thermocouples T001-T006, T009, T008	6/18/2014
Alicat MCR-500SLPM MFC SN 68858	2/4/2014
Alicat MCR-500SLPM-D MFC SN 68857	4/3/2014
Vaisala MI70/HMP77B S/N G5230040/H0320001	1/31/2014
Vaisala MI70/DMP74B S/N G5230040/H0320001	1/31/2014
Mott Corp Diluter Z8" OAL Model 7610S-1.375-24-2-AB	N/A
Fisher Dew Point Pen S/N 122277883	5/16/2014
N/A	

Notes: *No humidity control at this temperature. Ran chamber at 328°F with higher humidity (set to 12%, but only goes to 6.5% RH)
13:00: 3500 gr/lb, 173°F dp. Turn on heat tape.
13:30 increase temperature set point in chamber to 360°F.
Switched to bottom desiccant at start of test period.
The desiccant color wasn't great, so the dew point isn't very low.
Chamber continues to fluctuate a bit.
The dry air system water filter is half full at start of test, despite the fact that it was drained twice just before.
The dry air dew pt hit 10°F ~14:37, so switched back to top (~0°F).
Used a bore scope to inspect conditioner interior after test.
White 3M water indicator dots and some green marker is visible, so apparently no condensation formed.

JEF 8/11/13

Data Files
Environmental Chamber Data: 130801-hvs3-max.csv
Vaisala Dew Point Data (FIO): 2013-08-01 8-47.csv
Alicat Data (FIO): 20130801-0847-alicat.dat

Entries made by: JULIA FAHERTY
Signature/date: *[Signature]* 8/11/13
Technical Data Review performed by:
Signature/date: *[Signature]* 11/11/13

TH p# of 17
10
8/14/13

HIGH TEMPERATURE PROBE TESTING - Temperature / Humidity Only

Run No. TH-6
Date 8/2/13
Start/End Time 10:25/11:50
Testers JEF, JAG

Facility / Condition HV-S3 Max
Chamber Set Point 365°F / 1.5% RH
Diluter Orientation Horiz or Vert

	Start	Finish	
Time	10:25	11:50	
Chamber Temp	364	365	°F
Chamber Humidity	3.5	1.2	RH
Dilution flowcontroller	8.50	8.50	scfm
Dilution Dew Pt	0	10	°F
Dilution Temp	76	76	°F
Dilution P	15.1	15.1	psia
Sampling flowcontroller	9.20	9.20	scfm
Sampling Dew Pt	60	86	°F
Sampling Temp	83	44	°F
Sampling P	13.4	13.4	psia
Ambient pressure	1002	1002	mbar
Ambient humidity	48%	33%	RH
Ambient Temp	75	73	°F

Instruments Used:	Cal Due
Thermotron SE-2000-4 Env Chamber S/N 42857	4/2/2014
Type T Thermocouples Tool-Tool, Tool, Tool	6/18/2014
Alicat MCR-500SLPM MFC SN 68858	2/4/2014
Alicat MCR-500SLPM-D MFC SN 68857	4/3/2014
Vaisala MI70/HMP77B S/N G5230040/H0320001	1/31/2014
Vaisala MI70/DMP74B S/N G5230040/H0320001	1/31/2014
Mott Corp Diluter 28" OAL Model 7610S-1.375-24-2-AB	N/A
Fisher Dew Point Pen S/N 122277883	5/16/2014
N/A	

Notes: Set chamber to start at 6am at 238°F & 1% RH. Turned on heat tape (omega set point at 310°F is in the neighborhood of 350°F with calibrated thermocouples). At start-up, just ran dilution air (no total flow out of chamber) at 1 scfm. Set humidity to 7%, and it hit that value so continued to increase humidity. Because it should be at 338°F... Increase temp at ~9:50. Start w/ 300°F so it works w/o the "temp out of range" msg. 9:50: 331°F / 7.8% RH / 184°F dp / 5700 g/Lb Turned on flow thru both mass flow controllers. * No humidity control at 365°F. Start test using top desiccant. Chamber temperature is still oscillating at start of test, but the variability is less than 2 deg F. Pretty flat after 10:42, although RH drops. 2.7% RH at 10:42, 1.7% RH at 11:23. Opened up upstream end of

Data Files
Environmental Chamber Data: 130802-hvs3-max.csv
Vaisala Dew Point Data (FIO): 2013-08-02_9-52.csv
Alicat Data (FIO): 20130802_0951-alicat.dat

Entries made by: JULIA FLAHERTY
Signature/date: *Julia Flaherty* 8/2/13
Technical Data Review performed by:
Signature/date: *Deborah Colman* 11/11/13

diluter after this test. Thermocouples look good (where they should be). All 3M dots are white, green marker appears faded (heat effect?) but still visible. No condensation.

HIGH TEMPERATURE PROBE TESTING - Temperature / Humidity Only

TH p18 of 17
11
8/11/13

Run No. TH-7
Date 8/13/13
Start/End Time 11:35/12:35
Testers JEF

Facility / Condition HV-S3 Max
Chamber Set Point 365°F / 1.5% RH *
Diluter Orientation Horiz or Vert

	Start	Finish	
Time	11:35	12:35	
Chamber Temp	366	365	°F
Chamber Humidity	3.4	1.6	RH
Dilution flowcontroller	7.42	7.42	scfm
Dilution Dew Pt	-17	-17	°F
Dilution Temp	80	81	°F
Dilution P	15.0	15.0	psia
Sampling flowcontroller	8.13	8.13	scfm
Sampling Dew Pt	65	50	°F
Sampling Temp	91	91	°F
Sampling P	13.5	13.5	psia
Ambient pressure	1001	1001	mbar
Ambient humidity	30.3	29.8	RH
Ambient Temp	77.5	78.5	°F

Instruments Used:	Cal Due
✓ Thermotron SE-2000-4 Env Chamber S/N 42857	4/2/2014
✓ Type T Thermocouples T001 - T006, T009, T008	6/18/2014
✓ Alicat MCR-500SLPM MFC SN 68858	2/4/2014
✓ Alicat MCR-500SLPM-D MFC SN 68857	4/3/2014
✓ Vaisala MI70/HMP77B S/N G5230040/H0320001	1/31/2014
✓ Vaisala MI70/DMP74B S/N G5230040/H0320001	1/31/2014
✓ Mott Corp Diluter 28" OAL Model 7610S-1.375-24-2-AB	N/A
✓ Fisher Dew Point Pen S/N 122277883	5/16/2014
N/A	

Notes: Chamber set to 328°F & 0.4% RH, but only hits 284°F & 0.8% RH. ~73°F dp. Turn on heat tapes (set to 310°F) ~8:35. Turn on mass flow controllers ~8:52. Change chamber set point to 328°F / 2% RH ~9:00. Switched to lower desiccant (Fresh, New, never-baked) ~9:15. Dew pt ~ -18°F. BTW, something is cooking... under heat tape. Replace upper desiccant w/ baked beads that are a nice blue. The humidity hit 10% before I bumped up temperature. * No humidity control at 365°F. Padded the moisture before the test period, so the humidity will slowly drop over the course of the test. Temperature was still fluctuating a bit at start of test, +/- 1°F.

Data Files
Environmental Chamber Data: 130813_hvs3_max_norm.csv
Vaisala Dew Point Data (FIO): 2013-08-13_8-36.csv
Alicat Data (FIO): 20130813_0835_alicat.dat

Entries made by: <u>JULIA FLAHERTY</u>	Technical Data Review performed by:
Signature/date: <u>[Signature]</u> 8/13/13	Signature/date: <u>[Signature]</u> 11/11/13

TH p12 of 17

HIGH TEMPERATURE PROBE TESTING - Temperature / Humidity Only

Run No. TH-8
 Date 8/13/13
 Start/End Time 13:16/14:20
 Testers JFF

Facility / Condition HV-S3 Norm
 Chamber Set Point 313°F / 1.7% RH
 Diluter Orientation Horiz or Vert

	Start	Finish	
Time	13:16	14:20	
Chamber Temp	313	313	°F
Chamber Humidity	1.7	1.7	RH
Dilution flowcontroller	4.17	4.17	scfm
Dilution Dew Pt	-15	-17	°F
Dilution Temp	83	82	°F
Dilution P	14.8	14.7	psia
Sampling flowcontroller	4.88	4.88	scfm
Sampling Dew Pt	59	60	°F
Sampling Temp	94	94	°F
Sampling P	14.0	14.0	psia
Ambient pressure	1000	999.3	mbar
Ambient humidity	26.4	25.9	RH
Ambient Temp	81.6	81.5	°F

Instruments Used:	Cal Due
✓ Thermotron SE-2000-4 Env Chamber S/N 42857	4/2/2014
✓ Type T Thermocouples T001 - T006, T009, T008	6/18/2014
✓ Alicat MCR-500SLPM MFC SN 68858	2/4/2014
✓ Alicat MCR-500SLPM-D MFC SN 68857	4/3/2014
✓ Vaisala MI70/HMP77B S/N G5230040/H0320001	1/31/2014
✓ Vaisala MI70/DMP74B S/N G5230040/H0320001	1/31/2014
✓ Mott Corp Diluter 28" BAL Model 7610S-1.375-24-2-AB	N/A
✓ Fisher Dew Point Pen S/N 122277883	5/16/2014
N/A	

Notes: Still running the lower desiccant, which was fresh, never-baked beads with little previous use this morning. Omega heat tape set to 269°F (which actually corresponds to ~280°F on the calibrated Type T thermocouples installed under the heat tape). Temperature and relative humidity continue to fluctuate a bit at the start of this test. (+/- 1°F, 0.1% RH) Notice at the end of the test (of course!) the dilution flow rate was incorrectly set to 4.17 scfm instead of 4.07 scfm. This means slightly less than 1.3 acfm was sampled from the chamber. We're looking at varying the sample rate, so this small deviation should be fine. Used borescope to inspect interior. No signs of condensation.

Data Files

Environmental Chamber Data: 130813_hvs3_max_norm.csv
 Vaisala Dew Point Data (FIO): 2013-08-13 12:49.csv
 Alicat Data (FIO): 20130813_0833_alicat.dat

Entries made by: JULIA FLAHERTY Technical Data Review performed by:
 Signature/date [Signature] 8/13/13 Signature/date [Signature] 11/11/13

TH p13 of 17

HIGH TEMPERATURE PROBE TESTING - Temperature / Humidity Only

Run No. TH- 9
 Date 8/26/13
 Start/End Time 9:50/10:50
 Testers JEF

Facility / Condition HV-S3 Max
 Chamber Set Point 305°F / 1.5% RH *
 Diluter Orientation Horiz or Vert

Time	9:50 Start	10:50 Finish	
Chamber Temp	36.5	36.5	°F
Chamber Humidity	3.0	1.24	RH
Dilution flowcontroller	8.50	8.50	scfm
Dilution Dew Pt	-6	-4	°F
Dilution Temp	76	77	°F
Dilution P	15.1	15.1	psia
Sampling flowcontroller	9.20	9.20	scfm
Sampling Dew Pt	69	53	°F
Sampling Temp	86	85	°F
Sampling P	13.3	13.3	psia
Ambient pressure	999.0	998.8	mbar
Ambient humidity	43.5	37.8	RH
Ambient Temp	74.8	74.2	°F

MOVE DOWN ONE ROW

Instruments Used:	Cal Due
Thermon SE-2000-4 Env Chamber S/N 42857	4/2/2014
Type T Thermocouples T001 - T006, T009, T008	6/18/2014
Alicat MCR-500SLPM MFC SN 68858	2/4/2014
Alicat MCR-500SLPM-D MFC SN 68857	4/3/2014
Vaisala MI70/HMP77B S/N G5230040/H0320001	1/31/2014
Vaisala MI70/DMP74B S/N G5230040/H0320001	1/31/2014
Mott Corp Diluter 32" OAL Model 7610S-1.375-24-2-AB	N/A
Fisher Dew Point Pen S/N 122277883	5/16/2014
N/A	

Notes: Starting set point (328°F & 0.4% RH) was too restrictive for humidity, so the chamber only hit 265°F (and 0.8% RH). Changed set point to 328°F & 0.9% RH. While temperature is increasing, turn on heat tape (8:15 AM) with set point = 310°F. Inch the humidity up to 7.5%; which keeps the conditioned air dew point a few deg below the dry bulb... At 9:15, the RH was 7.3%, but I increased temperature set point to 305°F. (conditioned air was 82°F w/ 76°F dp).
 * humidity is not controlled by the chamber at this temperature. At 9:50 start time, temperature in the chamber was still oscillating around the set point (< 3°F). Pulled out the 4" glass fiber filter after this test. It's tinged yellow/orange (fluorescein?) and feels like it may have had moisture on it. Presumably condensation would have been during the start-up.
 < Notes on fluorescence below >

Data Files
Environmental Chamber Data: 130826_hvs3-max-norm.csv
Vaisala Dew Point Data (FIO): 2013-08-26_8-53.csv
Alicat Data (FIO): 20130826-0828-alicat.dat

Entries made by: JULIA FLAHERTY
 Signature/date: *Julia Flaherty* 8/26/13
 Technical Data Review performed by: *Chabell Golbach* 11/11/13
 Signature/date:

Fluorescence Measurements:
 Solid Std: 2612.77, 2611.71, 2611.28 RFU
 Solution Blank: 11.50; 11.40, 11.43 RFU
 Filter in 95.2g soln: 369.75, 366.50, 363.16 RFU
 ↳ 3.8 RFU/g

Turner Trilogy
 Sartorius Balance
 Whatman AutoVial
 Filter is still tinged yellow after wash.

HIGH TEMPERATURE PROBE TESTING - Temperature / Humidity Only

TH p13 of 17
14
8/14/13

Run No. TH-10
Date 8/26/13
Start/End Time 12:20/13:20
Testers JEF

Facility / Condition HV-S3 Norm
Chamber Set Point 313°F / 1.7%RH
Diluter Orientation Horiz or Vert

	Start	Finish	
Time	12:20	13:20	
Chamber Temp	312	313	°F
Chamber Humidity	1.7	1.7	RH
Dilution flowcontroller	7.63	7.63	scfm
Dilution Dew Pt	1	2	°F
Dilution Temp	81.0	80.4	°F
Dilution P	15.0	15.6	psia
Sampling flowcontroller	8.34	8.34	scfm
Sampling Dew Pt	44	44	°F
Sampling Temp	89	88	°F
Sampling P	13.6	13.6	psia
Ambient pressure	997.7	997.7	mbar
Ambient humidity	29.4	30.2	RH
Ambient Temp	79.6	78.9	°F

Instruments Used:	Cal Due
✓ Thermotron SE-2000-4 Env Chamber S/N 42857	4/2/2014
✓ Type T Thermocouples T001 - T006, T009, T008	6/18/2014
✓ Alicat MCR-500SLPM MFC SN 68858	2/4/2014
✓ Alicat MCR-500SLPM-D MFC SN 68857	4/3/2014
✓ Vaisala MI70/HMP77B S/N G5230040/H0320001	1/31/2014
✓ Vaisala MI70/DMP74B S/N G5230040/H0320001	1/31/2014
✓ Mott Corp Diluter 32" OAL Model 7610S-1.375-24-2-AB	N/A
✓ Fisher Dew Point Pen S/N 122277883	5/16/2014
N/A	

Notes: The chamber conditions have been slowly oscillating around the set point for a while, and the deviation from the set point is small, so the test was started at 12:20. Filter looks dry after test. Heat tape set to 270°F.

Data Files

Environmental Chamber Data: 130826_hvs3_max_norm.csv
Vaisala Dew Point Data (FIO): 2013-08-26 8-S3.csv
Alicat Data (FIO): 20130826-0828-alicat.dat

Entries made by: JULIA FLAHERTY
Signature/date: *Jul Flaherty* 8/26/13
Technical Data Review performed by:
Signature/date: *Elizabeth Solovick* 11/11/13

B.2 HV-S3 Aerosol Penetration Data Sheets

HIGH TEMPERATURE PROBE TESTING - Aerosol Penetration						
Aerosol and Dilution Data						
Run No.	AP-1			Facility	HV-S3	
Date	9/12/2013			Chamber Set Point	73.5°F / 50% RH	
Start/End Time	9:40 / 10:15			Diluter Flows	Norm Stack, Norm ISA	
Testers	JEF			Diluter Orientation	Horiz	
	Start	Finish		Materials and Equipment Used:		Cal Due
Time	9:40	10:15		Thermotron SE-2000-4 Env Chamber S/N 42857		4/2/2014
Chamber Temp	73.5	73.5	°F	Alicat MCR-500SLPM MFC SN 68858		2/4/2014
Chamber Humidity	50%	50%	RH	Alicat MCR-500SLPM-D MFC SN 68857		4/3/2014
Dilution flowcontroller	4.07	4.07	scfm	Vaisala MI70/HMP77B S/N G5230040/H0320001		1/31/2014
Dilution Dew Pt	0	3	°F	Vaisala MI70/DMP74B S/N G5230040/H0320001		1/31/2014
Dilution Temp	76.2	77.3	°F	Type T Thermocouples T004, T006, T008, T009		6/18/2014
Dilution P	14.7	14.7	psia	Mott Corp Diluter 32" OAL Model 7610S-1.375-24-2-AB		N/A
Sampling flowcontroller	4.88	4.88	scfm	Fisher Dew Point Pen S/N 122277883		5/16/2014
Sampling Dew Pt	15	16	°F	TSI VOAG, Model 345001 S/N 406		N/A
Sampling Temp	75	76	°F	VOAG Aerosol Solution ID AS02		made on 8/8/13
Sampling P	14.1	14.1	psia	TSI APS, Model 3321 S/N 70907086		7/29/2014
Ambient pressure	999.3	999.3	mbar	N/A		
Ambient humidity	36.8%	33.0%	RH			
Ambient Temp	76.4	77.0	°F	Droplet Diameter: $D_d = (6Q/\pi f)^{(1/3)}$		49.6 μm
VOAG Frequency	40.06	40.07	kHz			
VOAG Syringe Speed	4.6	4.6	$\times 10^{-4}$ cm/s		Aerosol concentration, C	0.0153
VOAG Dispersion Air	10	10	cc/min x 100		Aerosol density, ρ	0.8931
VOAG Dilution Air	70	70	LPM			
APS Mean AD	10.2	10.2	μm	Particle Diameter: $D_p = (C+I)^{(1/3)}D_d$		12.6 μm
APS Sig-G	1.111	1.09		Aerodynamic Diameter: $AD = D_p \cdot \text{SQRT}(\rho/1)$		11.9 μm
Notes: Room air case with no heat tape.						
Used upper desiccant system.						
/						
JF 9/12/13						
Data Files						
Environmental Chamber Data:	130912_hvs3_room_air.csv					
FIO Vaisala Dew Point Data:	2013-09-12_9_42.csv					
FIO Alicat Data:	20130912_0935_alicat.dat					
FIO APS Data:	test_sept_12_2013_1_conc_mass.txt					
Entries made by:	Julia Flaherty			Technical Data Review performed by:	Carmen Arimescu	
Signature/date	On File w/ Original 9/12/2013			Signature/date	On File w/ Original 3/13/2014	

HIGH TEMPERATURE PROBE TESTING - Aerosol Penetration								
Fluorometry Data								
Run No. AP-1			Facility HV-S3					
Date 9/12/2013			Chamber Set Point 73.5°F / 50% RH					
Start/End Time 8:40 / 11:25			Diluter Flows Norm Stack, Norm ISA					
Testers JEF			Diluter Orientation Horiz					
Materials and Equipment Used:								Cal Due
Turner Trilogy Fluorometer			S/N 720000895			N/A		
Sartorius QS 2000 Lab Balance			S/N 60502077			6/24/2014		
N/A								
Aerosol Wash Solution			ID AW07			Made on 9/10/2013		
Whatman AutoVial			N/A					
N/A								
		Wash Solution		Fluorescence				Aerosol
	Sample	Mass (g)	1 - RFU	2 - RFU	3 - RFU	Mean	RFU/g	Penetration
Pre-Test Wash	Fittings	74.2	82.43	84.97	85.40	84.3	1.1	
	Diluter	145.2	55.86	55.08	54.98	55.3	0.4	N/A
	Solid Std	N/A	2587.67	2587.43	2587.32	2587.5		
	Solution Blank	N/A	9.22	9.00	9.00	9.1		
First Wash	Filter	102.7	39.28	39.24	39.25	39.3	0.4	
	Fittings	72.4	63.70	63.92	63.66	63.8	0.9	0.8881
	Diluter	151.8	23.27	24.64	24.54	24.2	0.2	
	Solid Std	N/A	2423.09	2423.29	2423.29	2423.2		
	Filter Blank	99.0	14.50	16.54	16.75	15.9	0.2	
	Solution Blank	N/A	9.10	9.13	9.05	9.1		
Second Wash	Filter	105.6	15.44	14.98	14.68	15.0	0.1	
	Fittings	79.9	31.63	32.34	31.42	31.8	0.4	0.8770
	Diluter	148.8	13.97	13.98	13.95	14.0	0.1	
	Solid Std	N/A	2617.94	2618.51	2617.82	2618.1		
	Filter Blank	109.4	13.54	14.72	15.53	14.6	0.1	
	Solution Blank	N/A	9.14	9.19	9.15	9.2		
Third Wash	Filter	95.2	14.86	15.84	15.97	15.6	0.2	
	Fittings	72.9	29.36	29.48	29.32	29.4	0.4	0.8722
	Diluter	143.9	13.46	13.63	13.62	13.6	0.1	
	Solid Std	N/A	2610.60	2610.47	2610.34	2610.5		
	Filter Blank	83.9	15.63	15.45	15.53	15.5	0.2	
	Solution Blank	N/A	9.32	9.30	9.34	9.3		
Notes: Dry out the diluter after Pre-Test Wash using dilution air.								
Use AutoVial for everything on the first wash, then only filters on 2nd and 3rd wash.								
Did not blow out diluter with dilution air between washes.								
Used dilution air at end of 3rd wash. In addition to some liquid, gas (like party fog) came out, for about 1 min.								
Air was ~ 1scfm.								
The fluorescence values on the first wash wasn't as high as I'd expected. Perhaps because the flow rate was lower than previous tests? Se how AP-2 turns out.								
/								
Entries made by: Julia Flaherty			Technical Data Review performed by: Carmen Arimescu					
Signature/date: On File w/ Original 9/12/2013			Signature/date: On File w/ Original 3/13/2014					

HIGH TEMPERATURE PROBE TESTING - Aerosol Penetration						
Aerosol and Dilution Data						
Run No.	AP-2			Facility	HV-S3	
Date	9/12/2013			Chamber Set Point	73.5°F / 50% RH	
Start/End Time	12:07 / 12:50			Diluter Flows	Max Stack, Norm ISA	
Testers	JEF			Diluter Orientation	Horiz	
	Start	Finish		Materials and Equipment Used:		Cal Due
Time	12:07	12:50		Thermotron SE-2000-4 Env Chamber S/N 42857		4/2/2014
Chamber Temp	73.5	73.5	°F	Alicat MCR-500SLPM MFC	SN 68858	2/4/2014
Chamber Humidity	48.3%	50.0%	RH	Alicat MCR-500SLPM-D MFC	SN 68857	4/3/2014
Dilution flowcontroller	7.42	7.42	scfm	Vaisala MI70/HMP77B	S/N G5230040/H0320001	1/31/2014
Dilution Dew Pt	14.5	25	°F	Vaisala MI70/DMP74B	S/N G5230040/H0320001	1/31/2014
Dilution Temp	81.5	83.9	°F	Type T Thermocouples	T004, T006, T008, T009	6/18/2014
Dilution P	15.0	15.0	psia	Mott Corp Diluter 32" OAL	Model 7610S-1.375-24-2-AB	N/A
Sampling flowcontroller	8.13	8.13	scfm	Fisher Dew Point Pen	S/N 122277883	5/16/2014
Sampling Dew Pt	13	21	°F	TSI VOAG, Model 345001	S/N 406	N/A
Sampling Temp	79	82	°F	VOAG Aerosol Solution	ID AS02	made on 8/8/13
Sampling P	13.6	13.6	psia	TSI APS, Model 3321	S/N 70907086	7/29/2014
Ambient pressure	998.0	997.6	mbar	N/A		
Ambient humidity	28.2%	27.4%	RH			
Ambient Temp	79.4	80.4	°F	Droplet Diameter: $D_d = (6Q/(\pi f))^{1/3}$		49.5 μm
VOAG Frequency	40.20	40.20	kHz			
VOAG Syringe Speed	4.6	4.6	$\times 10^{-4}$ cm/s	Aerosol concentration, C		0.0153
VOAG Dispersion Air	10	10	cc/min $\times 100$	Aerosol density, ρ		0.8931
VOAG Dilution Air	70	70	LPM			
APS Mean AD	10.2	9.66	μm	Particle Diameter: $D_p = (C+)^{1/3} D_d$		12.6 μm
APS Sig-G	1.116	1.105		Aerodynamic Diameter: $AD = D_p \cdot \text{SQRT}(\rho/1)$		11.9 μm
Notes: Another room air case with no heat tape.						
Still using upper desiccant system. Probably need to change out desiccant beads after this test.						
/						
JF 9/12/13						
Data Files						
Environmental Chamber Data:	130912_hvs3_room_air.csv					
FIO Vaisala Dew Point Data:	2013-09-12_9_42.csv					
FIO Alicat Data:	20130912_0935_alicat.dat					
FIO APS Data:	test_sept_12_2013_1_conc_mass.txt					
Entries made by:	Julia Flaherty			Technical Data Review performed by:	Carmen Arimescu	
Signature/date	On File w/ Original 9/12/2013			Signature/date	On File w/ Original 3/13/2014	

HIGH TEMPERATURE PROBE TESTING - Aerosol Penetration								
Fluorometry Data								
Run No.	AP-2			Facility	HV-S3			
Date	9/12/2013			Chamber Set Point	73.5°F / 50% RH			
Start/End Time	13:00 / 13:50			Diluter Flows	Max Stack, Norm ISA			
Testers	JEF			Diluter Orientation	Horiz			
Materials and Equipment Used:				Cal Due				
Turner Trilogy Fluorometer		S/N 720000895		N/A				
Sartorius QS 2000 Lab Balance		S/N 60502077		6/24/2014				
N/A								
Aerosol Wash Solution		ID AW07		Made on 9/10/2013				
Whatman AutoVial		N/A						
N/A								
	Wash Solution		Fluorescence				RFU/g	Aerosol Penetration
	Sample	Mass (g)	1 - RFU	2 - RFU	3 - RFU	Mean		
Pre-Test Wash	Fittings	72.9	29.36	29.48	29.32	29.4	0.4	N/A
	Diluter	143.9	13.46	13.63	13.62	13.6	0.1	
	Solid Std	N/A	2610.60	2610.47	2610.34	2610.5		
	Solution Blank	N/A	9.32	9.30	9.34	9.3		
First Wash	Filter	96.1	84.74	84.59	84.45	84.6	0.9	0.8681
	Fittings	65.5	28.70	29.56	29.95	29.4	0.4	
	Diluter	145.1	29.01	28.79	30.08	29.3	0.2	
	Solid Std	N/A	2620.56	2620.06	2620.10	2620.2		
	Filter Blank	114.3	16.26	17.13	17.76	17.1	0.1	
	Solution Blank	N/A	9.93	9.94	10.04	10.0		
Second Wash	Filter	97.9	14.95	15.05	15.29	15.1	0.2	0.7473
	Fittings	64.5	17.96	19.00	18.66	18.5	0.3	
	Diluter	138.8	54.99	55.19	55.07	55.1	0.4	
	Solid Std	N/A	2607.15	2606.92	2606.61	2606.9		
	Filter Blank	93.1	13.89	16.19	14.39	14.8	0.2	
	Solution Blank	N/A	11.25	11.38	11.66	11.4		
Third Wash	Filter	91.2	15.99	16.46	16.93	16.5	0.2	0.7409
	Fittings	74.7	22.52	21.53	20.24	21.4	0.3	
	Diluter	135.9	24.81	25.00	25.26	25.0	0.2	
	Solid Std	N/A	2614.08	2614.27	2614.53	2614.3		
	Filter Blank	90.5	14.40	14.80	14.43	14.5	0.2	
	Solution Blank	N/A	11.63	11.65	11.97	11.8		
Notes: Pre-Test wash values are from AP-1 third wash.								
Use AutoVial for everything on the first wash, then only for filters on the 2nd and 3rd washes.								
/								
JF 9/12/13								
/								
Entries made by: Julia Flaherty			Technical Data Review performed by: Carmen Arimescu					
Signature/date: On File w/ Original 9/12/2013			Signature/date: On File w/ Original 3/13/2014					

HIGH TEMPERATURE PROBE TESTING - Aerosol Penetration									
Aerosol and Dilution Data									
Run No.	AP-3				Facility	HV-S3			
Date	9/13/2013				Chamber Set Point	313°F / 1.7% RH			
Start/End Time	10:25 / 11:05				Diluter Flows	Norm Stack, Norm ISA			
Testers	JEF				Diluter Orientation	Horiz			
	Start	Finish			Materials and Equipment Used:				Cal Due
Time	10:25	11:05			Thermotron SE-2000-4 Env Chamber S/N 42857				4/2/2014
Chamber Temp	313	313	°F		Alicat MCR-500SLPM MFC		SN 68858	2/4/2014	
Chamber Humidity	1.7%	1.7%	RH		Alicat MCR-500SLPM-D MFC		SN 68857	4/3/2014	
Dilution flowcontroller	4.07	4.07	scfm		Vaisala MI70/HMP77B		S/N G5230040/H0320001	1/31/2014	
Dilution Dew Pt	-24	-22	°F		Vaisala MI70/DMP74B		S/N G5230040/H0320001	1/31/2014	
Dilution Temp	80.4	79.1	°F		Type T Thermocouples T004, T006, T008, T009				6/18/2014
Dilution P	14.7	14.7	psia		Mott Corp Diluter 32" OAL		Model 7610S-1.375-24-2-AB	N/A	
Sampling flowcontroller	4.88	4.88	scfm		Fisher Dew Point Pen		S/N 122277883	5/16/2014	
Sampling Dew Pt	70	70	°F		TSI VOAG, Model 345001		S/N 406	N/A	
Sampling Temp	113	112	°F		VOAG Aerosol Solution		ID AS02	made on 8/8/13	
Sampling P	14.0	14.0	psia		TSI APS, Model 3321		S/N 70907086	7/29/2014	
Ambient pressure	994.8	994.4	mbar		N/A				
Ambient humidity	28.4%	32.1%	RH						
Ambient Temp	79.2	78.4	°F		Droplet Diameter: $D_d = (6Q/πf)^{1/3}$			49.5 μm	
VOAG Frequency	40.19	40.20	kHz						
VOAG Syringe Speed	4.6	4.6	x 10 ⁻⁴ cm/s				Aerosol concentration, C	0.0153	
VOAG Dispersion Air	10	10	cc/min x 100				Aerosol density, ρ	0.8931	
VOAG Dilution Air	70	70	LPM						
APS Mean AD	9.38	9.53	μm		Particle Diameter: $D_p = (C+)^{1/3}D_d$			12.6 μm	
APS Sig-G	1.105	1.116			Aerodynamic Diameter: $AD = D_p \cdot \text{SQRT}(\rho/1)$			11.9 μm	
Notes: Turn on dilution and pumps at 9:15. Omega heat tapes set to 275°F. Chamber was set to 313°F / 0.3%RH, but is actually at 263°F / 0.8%RH (65°F dp). Turn on AS02 jet at 9:38. Start APS to check particle size at 9:48.									
Data Files Environmental Chamber Data: 130913_hvs3_norm.csv FIO Vaisala Dew Point Data: 2013-09-13 10_09.csv FIO Alicat Data: 20130913_0913_alicat.dat FIO APS Data: test_sept_13_2013_1_conc_mass.txt									
Entries made by:	Julia Flaherty				Technical Data Review performed by:	Carmen Arimescu			
Signature/date	On File w/ Original 9/13/2013				Signature/date	On File w/ Original 3/13/2014			

HIGH TEMPERATURE PROBE TESTING - Aerosol Penetration									
Fluorometry Data									
Run No.	AP-3			Facility	HV-S3				
Date	9/13/2013			Chamber Set Point	313°F / 1.7% RH				
Start/End Time	8:25 / 12:10			Diluter Flows	Norm Stack, Norm ISA				
Testers	JEF			Diluter Orientation	Horiz				
Materials and Equipment Used:				Cal Due					
Turner Trilogy Fluorometer		S/N 720000895		N/A					
Sartorius QS 2000 Lab Balance		S/N 60502077		6/24/2014					
N/A									
Aerosol Wash Solution		ID AW08		Made on 9/12/2013					
Whatman AutoVial				N/A					
N/A									
		Wash Solution		Fluorescence				Aerosol Penetration	
	Sample	Mass (g)		1 - RFU	2 - RFU	3 - RFU	Mean	RFU/g	
Pre-Test Wash	Fittings	79.3		15.39	15.32	15.36	15.4	0.2	N/A
	Diluter	143.5		18.09	18.49	18.40	18.3	0.1	
	Solid Std	N/A		2405.06	2404.67	2404.27	2404.7		
	Solution Blank	N/A		8.60	8.64	8.49	8.6		
First Wash	Filter	102.9		6347.97	6340.44	6348.66	6345.7	61.7	0.9955
	Fittings	60.2		228.03	228.64	228.57	228.4	3.8	
	Diluter	149.0		43.33	44.56	44.89	44.3	0.3	
	Solid Std	N/A		2443.68	2443.27	2444.9	2444.0		
	Filter Blank	100.9		15.44	16.01	16.13	15.9	0.2	
	Solution Blank	N/A		8.66	8.66	8.74	8.7		
Second Wash	Filter	93.0		1350.55	1338.94	1342.09	1343.9	14.5	0.9951
	Fittings	65.5		226.25	226.68	227.41	226.8	3.5	
	Diluter	143.5		15.81	16.09	16.12	16.0	0.1	
	Solid Std	N/A		2596.96	2596.81	2597.98	2597.3		
	Filter Blank	91.6		16.49	16.80	16.27	16.5	0.2	
	Solution Blank	N/A		9.92	10.07	10.39	10.1		
Third Wash	Filter	98.7		365.43	363.44	365.91	364.9	3.7	0.9944
	Fittings	60.3		80.55	79.83	79.18	79.9	1.3	
	Diluter	144.7		12.82	12.80	12.85	12.8	0.1	
	Solid Std	N/A		2613.19	2614.05	2613.71	2613.7		
	Filter Blank	92.2		15.07	15.45	15.3	15.3	0.2	
	Solution Blank	N/A		10.64	10.57	10.81	10.7		
Notes: Used an AutoVial for all of the 1st wash samples, then only the filters for 2nd and 3rd washes.									
Note the small difference between 1st and 2nd wash for fittings. Don't exactly know why...									
/									
JF 9/13/13									
/									
Entries made by:	Julia Flaherty			Technical Data Review performed by:			Carmen Arimescu		
Signature/date	On File w/ Original 9/13/2013			Signature/date			On File w/ Original 3/13/2014		

HIGH TEMPERATURE PROBE TESTING - Aerosol Penetration							
Aerosol and Dilution Data							
Run No.	AP-4			Facility	HV-S3		
Date	9/16/2013			Chamber Set Point	313°F / 1.7% RH		
Start/End Time	12:50 / 13:30			Diluter Flows	Max Stack, Norm ISA		
Testers	JEF			Diluter Orientation	Horiz		
	Start	Finish		Materials and Equipment Used:			Cal Due
Time	12:50	13:30		Thermotron SE-2000-4 Env Chamber S/N 42857			4/2/2014
Chamber Temp	312	313	°F	Alicat MCR-500SLPM MFC SN 68858			2/4/2014
Chamber Humidity	1.7%	1.7%	RH	Alicat MCR-500SLPM-D MFC SN 68857			4/3/2014
Dilution flowcontroller	7.42	7.42	scfm	Vaisala MI70/HMP77B S/N G5230040/H0320001			1/31/2014
Dilution Dew Pt	-23	-16	°F	Vaisala MI70/DMP74B S/N G5230040/H0320001			1/31/2014
Dilution Temp	80.5	79.6	°F	Type T Thermocouples T004, T006, T008, T009			6/18/2014
Dilution P	15.0	15.0	psia	Mott Corp Diluter 32" OAL Model 7610S-1.375-24-2-AB			N/A
Sampling flowcontroller	8.13	8.13	scfm	Fisher Dew Point Pen S/N 122277883			5/16/2014
Sampling Dew Pt	49	48	°F	TSI VOAG, Model 345001 S/N 406			N/A
Sampling Temp	100	99	°F	VOAG Aerosol Solution ID AS02 made on 8/8/13			
Sampling P	13.5	13.5	psia	TSI APS, Model 3321 S/N 70907086			7/29/2014
Ambient pressure	996.7	996.2	mbar	N/A			
Ambient humidity	29.2%	32.9%	RH				
Ambient Temp	79.0	77.7	°F	Droplet Diameter: Dd = (6Q/πf)^(1/3)			49.5 μm
VOAG Frequency	40.11	40.11	kHz				
VOAG Syringe Speed	4.6	4.6	x 10 ⁻⁴ cm/s	Aerosol concentration, C			0.0153
VOAG Dispersion Air	10	10	cc/min x 100	Aerosol density, ρ			0.8931
VOAG Dilution Air	70	70	LPM				
APS Mean AD	9.20	9.33	μm	Particle Diameter: Dp = (C+I)^(1/3)Dd			12.6 μm
APS Sig-G	1.171	1.121		Aerodynamic Diameter: AD = Dp*SQRT(ρ)/1			11.9 μm
Notes: Turn on heat tape ~11:00, set point on Omega is 275°F.							
Turn on APS ~12:25 to check on AS02 particle size. Chamber is still oscillating around the temperature set point.							
Fixed the flex duct for this test. Prior to this one, there was a kink in the duct between the aerosol injection probe and shrouded probe. The tip of the aerosol injection probe may have been sticking out of the duct a bit as well.							
/							
JEF 9/16/13							
Data Files							
Environmental Chamber Data:		130916_hvs3_norm.csv					
FIO Vaisala Dew Point Data:		2013-09-169_11_21.csv					
FIO Alicat Data:		20130916_1114_alicat.dat					
FIO APS Data:		test_sept_16_2013_1_conc_mass.txt					
Entries made by:	Julia Flaherty			Technical Data Review performed by:	Carmen Arimescu		
Signature/date	On File w/ Original 9/16/2013			Signature/date	On File w/ Original 3/13/2014		

HIGH TEMPERATURE PROBE TESTING - Aerosol Penetration								
Fluorometry Data								
Run No.	AP-4			Facility	HV-S3			
Date	9/16/2013			Chamber Set Point	313°F / 1.7% RH			
Start/End Time	10:35 / 14:35			Diluter Flows	Max Stack, Norm ISA			
Testers	JEF			Diluter Orientation	Horiz			
Materials and Equipment Used:								Cal Due
Turner Trilogy Fluorometer		S/N 720000895			N/A			
Sartorius QS 2000 Lab Balance		S/N 60502077			6/24/2014			
N/A								
Aerosol Wash Solution		ID AW08		Made on 9/12/2013				
Whatman AutoVial		N/A						
N/A								
	Wash Solution		Fluorescence				Aerosol Penetration	
	Sample	Mass (g)	1 - RFU	2 - RFU	3 - RFU	Mean	RFU/g	
Pre-Test Wash	Fittings	68.7	37.28	37.28	37.13	37.2	0.5	N/A
	Diluter	99.7	38.01	38.43	38.47	38.3	0.4	
	Solid Std	N/A	2611.98	2611.50	2611.58	2611.7		
	Solution Blank	N/A	9.05	8.94	8.98	9.0		
First Wash	Filter	98.6	10138.05	10192.10	10158.95	10163.0	103.1	0.9979
	Fittings	61.7	197.48	197.25	198.94	197.9	3.2	
	Diluter	132.4	29.50	29.50	29.87	29.6	0.2	
	Solid Std	N/A	2616.16	2616.11	2616.28	2616.2		
	Filter Blank	93.2	14.28	14.39	14.20	14.3	0.2	
	Solution Blank	N/A	9.09	9.01	9.33	9.1		
Second Wash	Filter	93.9	465.65	466.11	464.22	465.3	5.0	0.9970
	Fittings	68.3	16.06	15.98	16.08	16.0	0.2	
	Diluter	135.9	14.98	14.99	14.99	15.0	0.1	
	Solid Std	N/A	2607.98	2607.70	2607.72	2607.8		
	Filter Blank	92.2	12.40	12.79	12.60	12.6	0.1	
	Solution Blank	N/A	10.17	10.02	11.18	10.5		
Third Wash	Filter	80.7	208.88	208.94	208.54	208.8	2.6	0.9962
	Fittings	53.9	12.37	12.64	12.77	12.6	0.2	
	Diluter	132.7	13.39	13.62	13.32	13.4	0.1	
	Solid Std	N/A	2613.68	2612.78	2612.54	2613.0		
	Filter Blank	82.3	10.57	11.16	11.01	10.9	0.1	
	Solution Blank	N/A	11.84	11.82	11.59	11.8		
Notes: Used an AutoVial for all of the 1st wash samples, then only the filters for 2nd and 3rd washes.								
/								
JF 9/16/13								
/								
Entries made by: Julia Flaherty			Technical Data Review performed by: Carmen Arimescu					
Signature/date: On File w/ Original 9/16/2013			Signature/date: On File w/ Original 3/13/2014					

HIGH TEMPERATURE PROBE TESTING - Aerosol Penetration						
Aerosol and Dilution Data						
Run No.	AP-5			Facility	HV-S3	
Date	9/19/2013			Chamber Set Point	313°F / 1.7% RH	
Start/End Time	11:15 / 11:45			Diluter Flows	Norm Stack, Norm ISA	
Testers	JEF, JAG			Diluter Orientation	Mostly Vert	
	Start	Finish		Materials and Equipment Used:		Cal Due
Time	11:15	11:45		Thermotron SE-2000-4 Env Chamber S/N 42857		4/2/2014
Chamber Temp	313	313	°F	Alicat MCR-500SLPM MFC	SN 68858	2/4/2014
Chamber Humidity	1.7%	1.7%	RH	Alicat MCR-500SLPM-D MFC	SN 68857	4/3/2014
Dilution flowcontroller	4.07	4.07	scfm	Vaisala MI70/HMP77B	S/N G5230040/H0320001	1/31/2014
Dilution Dew Pt	-16	-10	°F	Vaisala MI70/DMP74B	S/N G5230040/H0320001	1/31/2014
Dilution Temp	75.4	74.0	°F	Type T Thermocouples	T004 - T006, T008, T009	6/18/2014
Dilution P	14.8	14.8	psia	Mott Corp Diluter 32" OAL	Model 7610S-1.375-24-2-AB	N/A
Sampling flowcontroller	4.88	4.88	scfm	Fisher Dew Point Pen	S/N 122277883	5/16/2014
Sampling Dew Pt	71	72	°F	TSI VOAG, Model 345001	S/N 406	N/A
Sampling Temp	107	107	°F	VOAG Aerosol Solution	ID AS02	made on 8/8/13
Sampling P	14.0	14.0	psia	TSI APS, Model 3321	S/N 70907086	7/29/2014
Ambient pressure	1003	1003	mbar	N/A		
Ambient humidity	28.5%	31.5%	RH			
Ambient Temp	76.3	74.9	°F	Droplet Diameter: $Dd = (6Q/πf)^{1/3}$		49.5 μm
VOAG Frequency	40.12	40.13	kHz			
VOAG Syringe Speed	4.6	4.6	x 10 ⁻⁴ cm/s	Aerosol concentration, C		0.0153
VOAG Dispersion Air	10	10	cc/min x 100	Aerosol density, ρ		0.8931
VOAG Dilution Air	70	70	LPM			
APS Mean AD	9.31	8.96	μm	Particle Diameter: $Dp = (C+)^{1/3}Dd$		12.6 μm
APS Sig-G	1.325	1.142		Aerodynamic Diameter: $AD = Dp \cdot \sqrt{ρ}$		11.9 μm
Notes: Turn on heat tapes at around 9:22.						
Turn on dilution, sample flows around 9:38.						
Diluter is installed at about 18.5° from vertical due to the length. With fittings, it's an inch or two taller than the space available between the shrouded probe transport tube and the floor.						
The aerosol injection probe has some condensation before installing VOAG tubing.						
/ JEF 9/19/13						
Data Files						
Environmental Chamber Data: 130919_hvs3_norm.csv						
FIO Vaisala Dew Point Data: 2013-09-19_9_49.csv						
FIO Alicat Data: 20130919_0935_alicat.dat						
FIO APS Data: test_sept_19_2013_1_conc_mass.txt						
Entries made by:	Julia Flaherty			Technical Data Review performed by:	Carmen Arimescu	
Signature/date	On File w/ Original 9/19/2013			Signature/date	On File w/ Original 3/13/2014	

HIGH TEMPERATURE PROBE TESTING - Aerosol Penetration									
Fluorometry Data									
Run No.	AP-5			Facility	HV-S3				
Date	9/19/2013			Chamber Set Point	313°F / 1.7% RH				
Start/End Time	8:40 / 13:00			Diluter Flows	Norm Stack, Norm ISA				
Testers	JEF, JAG			Diluter Orientation	Mostly Vert (18.5° from vert)				
Materials and Equipment Used:									
			Cal Due						
Turner Trilogy Fluorometer			S/N 720000895				N/A		
Sartorius QS 2000 Lab Balance			S/N 60502077				6/24/2014		
N/A									
Aerosol Wash Solution			ID AW09				Made on 9/17/2013		
Whatman AutoVial			N/A						
N/A									
	Wash Solution			Fluorescence				Aerosol Penetration	
	Sample	Mass (g)		1 - RFU	2 - RFU	3 - RFU	Mean	RFU/g	
Pre-Test Wash	Fittings	96.8		54.23	55.08	54.92	54.7	0.6	
	Diluter	143.2		17.41	17.91	17.22	17.5	0.1	N/A
	Solid Std	N/A		2607.62	2607.32	2607.20	2607.4		
	Solution Blank	N/A		8.01	8.17	8.08	8.1		
First Wash	Filter	99.2		9002.46	9017.36	9043.58	9021.1	90.9	
	Fittings	91.8		154.85	151.90	151.81	152.9	1.7	0.9984
	Diluter	157.7		23.94	23.87	23.54	23.8	0.2	
	Solid Std	N/A		2615.38	2614.71	2615.34	2615.1		
	Filter Blank	98.2		11.94	12.04	11.87	12.0	0.1	
	Solution Blank	N/A		8.72	8.60	8.72	8.7		
Second Wash	Filter	89.5		296.27	298.57	297.49	297.4	3.3	
	Fittings	79.6		18.91	18.93	19.02	19.0	0.2	0.9973
	Diluter	147.9		16.45	16.30	16.53	16.4	0.1	
	Solid Std	N/A		2618.84	2618.61	2618.57	2618.7		
	Filter Blank	92.9		17.81	17.70	17.66	17.7	0.2	
	Solution Blank	N/A		10.24	10.15	9.73	10.0		
Third Wash	Filter	85.6		70.62	70.83	71.26	70.9	0.8	
	Fittings	64.6		62.40	62.78	62.98	62.7	1.0	0.9965
	Diluter	151.5		12.87	12.91	12.88	12.9	0.1	
	Solid Std	N/A		2622.67	2621.89	2621.55	2622.0		
	Filter Blank	83.0		11.12	11.14	11.19	11.2	0.1	
	Solution Blank	N/A		10.64	10.51	10.47	10.5		
Notes: Used an AutoVial for everything on 1st wash, then only filters for 2nd and 3rd wash.									
/									
JF 9/19/13									
Entries made by:	Julia Flaherty			Technical Data Review performed by:	Carmen Arimescu				
Signature/date	On File w/ Original 9/19/2013			Signature/date	On File w/ Original 3/13/2014				

HIGH TEMPERATURE PROBE TESTING - Aerosol Penetration						
Aerosol and Dilution Data						
Run No.	AP-6			Facility	HV-S3	
Date	9/19/2013			Chamber Set Point	313°F / 1.7% RH	
Start/End Time	14:12 / 14:45			Diluter Flows	Max Stack, Norm ISA	
Testers	JEF			Diluter Orientation	Mostly Vert	
	Start	Finish		Materials and Equipment Used:		Cal Due
Time	14:12	14:45		Thermotron SE-2000-4 Env Chamber S/N 42857		4/2/2014
Chamber Temp	313	313	°F	Alicat MCR-500SLPM MFC SN 68858		2/4/2014
Chamber Humidity	1.7%	1.7%	RH	Alicat MCR-500SLPM-D MFC SN 68857		4/3/2014
Dilution flowcontroller	7.42	7.42	scfm	Vaisala MI70/HMP77B S/N G5230040/H0320001		1/31/2014
Dilution Dew Pt	-2	0	°F	Vaisala MI70/DMP74B S/N G5230040/H0320001		1/31/2014
Dilution Temp	80.2	79.0	°F	Type T Thermocouples T004 - T006, T008, T009		6/18/2014
Dilution P	15.1	15.1	psia	Mott Corp Diluter 32" OAL Model 7610S-1.375-24-2-AB		N/A
Sampling flowcontroller	8.13	8.13	scfm	Fisher Dew Point Pen S/N 122277883		5/16/2014
Sampling Dew Pt	52	55	°F	TSI VOAG, Model 345001 S/N 406		N/A
Sampling Temp	101	101	°F	VOAG Aerosol Solution ID AS02		made on 8/8/13
Sampling P	13.4	13.4	psia	TSI APS, Model 3321 S/N 70907086		7/29/2014
Ambient pressure	1000	999.9	mbar	N/A		
Ambient humidity	26.1%	27.9%	RH			
Ambient Temp	80.4	78.4	°F	Droplet Diameter: $Dd = (6Q/πf)^{1/3}$		47.6 μm
VOAG Frequency	45.29	45.31	kHz			
VOAG Syringe Speed	4.6	4.6	x 10 ⁻⁴ cm/s	Aerosol concentration, C		0.0153
VOAG Dispersion Air	10	10	cc/min x 100	Aerosol density, ρ		0.8931
VOAG Dilution Air	70	70	LPM			
APS Mean AD	9.36	8.95	μm	Particle Diameter: $Dp = (C+)^{1/3}Dd$		12.1 μm
APS Sig-G	1.136	1.150		Aerodynamic Diameter: $AD = Dp \cdot \sqrt{ρ}/1$		11.4 μm
Notes: Turn on air flows ~13:30. Still using bottom desiccant, with -5°F dp, since conditioned air dew point is 16°F.						
Will need to switch desiccant before "real" test.						
Diluter is installed at about 12° from vertical.						
Switched to upper desiccant at 13:59.						
JEF 9/19/13						
Data Files						
Environmental Chamber Data: 130919_hvs3_norm.csv						
FIO Vaisala Dew Point Data: 2013-09-19_9_49.csv						
FIO Alicat Data: 20130919_0935_alicat.dat						
FIO APS Data: test_sept_19_2013_1_conc_mass.txt						
Entries made by:	Julia Flaherty			Technical Data Review performed by:	Carmen Arimescu	
Signature/date	On File w/ Original 9/19/2013			Signature/date	On File w/ Original 3/13/2014	

HIGH TEMPERATURE PROBE TESTING - Aerosol Penetration								
Fluorometry Data								
Run No.	AP-6			Facility	HV-S3			
Date	9/19/2013			Chamber Set Point	313°F / 1.7% RH			
Start/End Time	15:15 / 16:00			Diluter Flows	Max Stack, Norm ISA			
Testers	JEF			Diluter Orientation	Mostly Vert (18.5° from vert)			
Materials and Equipment Used:				Cal Due				
Turner Trilogy Fluorometer		S/N 720000895		N/A				
Sartorius QS 2000 Lab Balance		S/N 60502077		6/24/2014				
N/A								
Aerosol Wash Solution		ID AW09		Made on 9/17/2013				
Whatman AutoVial		N/A						
N/A								
	Wash Solution		Fluorescence					Aerosol Penetration
	Sample	Mass (g)	1 - RFU	2 - RFU	3 - RFU	Mean	RFU/g	
Pre-Test Wash	Fittings	64.6	62.40	62.78	62.98	62.7	1.0	N/A
	Diluter	151.5	12.87	12.91	12.88	12.9	0.1	
	Solid Std	N/A	2622.67	2621.89	2621.55	2622.0		
	Solution Blank	N/A	10.64	10.51	10.47	10.5		
First Wash	Filter	89.8	8390.84	8445.37	8373.82	8403.3	93.6	0.9963
	Fittings	73.5	212.02	212.75	211.89	212.2	2.9	
	Diluter	156.8	56.57	56.25	56.72	56.5	0.4	
	Solid Std	N/A	2612.10	2612.20	2612.05	2612.1		
	Filter Blank	86.0	13.45	13.36	13.02	13.3	0.2	
	Solution Blank	N/A	11.37	12.06	12.24	11.9		
Second Wash	Filter	86.1	664.60	662.48	663.05	663.4	7.7	0.9955
	Fittings	64.6	37.18	36.88	37.37	37.1	0.6	
	Diluter	134.2	14.84	14.85	14.85	14.8	0.1	
	Solid Std	N/A	2613.89	2613.39	2612.96	2613.4		
	Filter Blank	80.6	13.48	13.68	13.15	13.4	0.2	
	Solution Blank	N/A	11.84	12.84	12.26	12.3		
Third Wash	Filter	68.7	261.65	262.13	263.58	262.5	3.8	0.9950
	Fittings	60.9	38.66	38.40	38.59	38.6	0.6	
	Diluter	139.9	11.56	11.42	11.45	11.5	0.1	
	Solid Std	N/A	2616.57	2617.40	2617.80	2617.3		
	Filter Blank	69.3	11.23	11.24	11.46	11.3	0.2	
	Solution Blank	N/A	12.71	12.70	12.69	12.7		
Notes: Pre-Test wash values are the third wash from AP-5.								
Used AutoVial for everything on the 1st wash, then only filters for 2nd and 3rd washes.								
/								
JF 9/19/13								
/								
Entries made by: Julia Flaherty			Technical Data Review performed by: Carmen Arimescu					
Signature/date: On File w/ Original 9/19/2013			Signature/date: On File w/ Original 3/13/2014					

HIGH TEMPERATURE PROBE TESTING - Aerosol Penetration						
Aerosol and Dilution Data						
Run No.	AP-7			Facility	HV-S3	
Date	9/24/2013			Chamber Set Point	313°F / 1.7% RH	
Start/End Time	12:15 / 12:45			Diluter Flows	Norm Stack, Norm ISA	
Testers	JEF			Diluter Orientation	Nearly Vert (20° from vert)	
	Start	Finish		Materials and Equipment Used:		Cal Due
Time	12:15	12:45		Thermotron SE-2000-4 Env Chamber S/N 42857		4/2/2014
Chamber Temp	313	313	°F	Alicat MCR-500SLPM MFC SN 68858		2/4/2014
Chamber Humidity	1.7%	1.7%	RH	Alicat MCR-500SLPM-D MFC SN 68857		4/3/2014
Dilution flowcontroller	4.07	4.07	scfm	Vaisala MI70/HMP77B S/N G5230040/H0320001		1/31/2014
Dilution Dew Pt	1	3	°F	Vaisala MI70/DMP74B S/N G5230040/H0320001		1/31/2014
Dilution Temp	14.5	73.3	°F	Type T Thermocouples T004 - T006, T008, T009		6/18/2014
Dilution P	14.7	14.7	psia	Mott Corp Diluter 32" OAL Model 7610S-1.375-24-2-AB		N/A
Sampling flowcontroller	4.88	4.88	scfm	Fisher Dew Point Pen S/N 122277883		5/16/2014
Sampling Dew Pt	71	72	°F	TSI VOAG, Model 345001 S/N 406		N/A
Sampling Temp	105	105	°F	VOAG Aerosol Solution ID AS03 made on 9/19/13		
Sampling P	13.9	13.9	psia	TSI APS, Model 3321 S/N 70907086		7/29/2014
Ambient pressure	995.5	995.2	mbar	N/A		
Ambient humidity	33.2%	37.1%	RH			
Ambient Temp	74.5	74.2	°F	Droplet Diameter: $D_d = (6Q/\pi f)^{1/3}$		49.9 μm
VOAG Frequency	40.20	40.21	kHz			
VOAG Syringe Speed	4.7	4.7	$\times 10^{-4}$ cm/s	Aerosol concentration, C		0.0165
VOAG Dispersion Air	10	10	cc/min x 100	Aerosol density, ρ		0.8931
VOAG Dilution Air	70	70	LPM			
APS Mean AD	8.99	8.45	μm	Particle Diameter: $D_p = (C+)^{1/3} D_d$		12.9 μm
APS Sig-G	1.124	1.228		Aerodynamic Diameter: $AD = D_p \cdot \text{SQRT}(\rho)/1$		12.2 μm
Notes: Omega heat tapes set to 275°F.						
Used filtered aerosol solution.						
/						
JEF 9/24/13						
Data Files						
Environmental Chamber Data:		130927_hvs3_norm.csv				
FIO Vaisala Dew Point Data:		2013-09-24 11_10.csv				
FIO Alicat Data:		20130924_1046_alicat.dat				
FIO APS Data:		test_sept_24_2013_1_conc_mass.txt				
Entries made by:	Julia Flaherty			Technical Data Review performed by:	Carmen Arimescu	
Signature/date	On File w/ Original 9/24/2013			Signature/date	On File w/ Original 3/13/2014	

HIGH TEMPERATURE PROBE TESTING - Aerosol Penetration									
Fluorometry Data									
Run No.	AP-7			Facility	HV-S3				
Date	9/24/2013			Chamber Set Point	313°F / 1.7% RH				
Start/End Time	10:00 / 13:50			Diluter Flows	Norm Stack, Norm ISA				
Testers	JEF			Diluter Orientation	Nearly Vert (20° from vert)				
Materials and Equipment Used:				Cal Due					
Turner Trilogy Fluorometer		S/N 720000895		N/A					
Sartorius QS 2000 Lab Balance		S/N 60502077		6/24/2014					
N/A									
Aerosol Wash Solution		ID AW10		Made on 9/20/2013					
Whatman AutoVial				N/A					
N/A									
	Wash Solution		Fluorescence					Aerosol Penetration	
	Sample	Mass (g)	1 - RFU	2 - RFU	3 - RFU	Mean	RFU/g		
Pre-Test Wash	Fittings	68.2	17.55	17.48	17.54	17.5	0.3	N/A	
	Diluter	127.5	19.76	19.70	19.74	19.7	0.2		
	Solid Std	N/A	2600.63	2599.99	2600.02	2600.2			
	Solution Blank	N/A	8.59	8.94	8.85	8.8			
First Wash	Filter	94.2	7688.87	7677.64	7669.33	7678.6	81.5	0.9977	
	Fittings	64.1	118.39	119.12	119.29	118.9	1.9		
	Diluter	138.5	26.23	26.02	26.34	26.2	0.2		
	Solid Std	N/A	2575.47	2575.18	2574.19	2574.9			
	Filter Blank	99.9	14.25	13.82	13.89	14.0	0.1		
	Solution Blank	N/A	8.89	8.99	9.19	9.0			
Second Wash	Filter	79.5	684.96	689.46	684.59	686.3	8.6	0.9968	
	Fittings	68.6	28.83	29.07	29.00	29.0	0.4		
	Diluter	121.1	12.73	13.39	12.89	13.0	0.1		
	Solid Std	N/A	2595.47	2595.27	2595.37	2595.4			
	Filter Blank	80.5	17.58	17.39	17.11	17.4	0.2		
	Solution Blank	N/A	10.26	10.35	10.4	10.3			
Third Wash	Filter	67.8	297.20	294.63	296.41	296.1	4.4	0.9960	
	Fittings	67.8	12.86	12.97	13.1	13.0	0.2		
	Diluter	114.1	10.61	10.69	11.11	10.8	0.1		
	Solid Std	N/A	2593.18	2593.17	2592.33	2592.9			
	Filter Blank	64.7	12.95	12.92	12.77	12.9	0.2		
	Solution Blank	N/A	10.52	10.43	10.28	10.4			
Notes: Used AutoVial for everything on the first wash, then only filters for 2nd and 3rd washes.									
/									
JF 9/24/13									
/									
Entries made by:	Julia Flaherty			Technical Data Review performed by:			Carmen Arimescu		
Signature/date	On File w/ Original 9/24/2013			Signature/date			On File w/ Original 3/13/2014		

HIGH TEMPERATURE PROBE TESTING - Aerosol Penetration						
Aerosol and Dilution Data						
Run No.	AP-8			Facility	HV-S3	
Date	9/27/2013			Chamber Set Point	365°F / 1.5% RH *	
Start/End Time	14:30 / 15:00			Diluter Flows	Max Stack, Norm ISA	
Testers	JEF			Diluter Orientation	Mostly Vert	
	Start	Finish		Materials and Equipment Used:		Cal Due
Time	14:30	15:00		Thermotron SE-2000-4 Env Chamber S/N 42857		4/2/2014
Chamber Temp	365	365	°F	Alicat MCR-500SLPM MFC	SN 68858	2/4/2014
Chamber Humidity	2.0%	0.8%	RH	Alicat MCR-500SLPM-D MFC	SN 68857	4/3/2014
Dilution flowcontroller	7.42	7.42	scfm	Vaisala MI70/HMP77B	S/N G5230040/H0320001	1/31/2014
Dilution Dew Pt	2	-3	°F	Vaisala MI70/DMP74B	S/N G5230040/H0320001	1/31/2014
Dilution Temp	76.8	77.7	°F	Type T Thermocouples	T004 - T006, T008, T009	6/18/2014
Dilution P	15.1	15.1	psia	Mott Corp Diluter 32" OAL	Model 7610S-1.375-24-2-AB	N/A
Sampling flowcontroller	8.13	8.13	scfm	Fisher Dew Point Pen	S/N 122277883	5/16/2014
Sampling Dew Pt	74	46	°F	TSI VOAG, Model 345001	S/N 406	N/A
Sampling Temp	100	101	°F	VOAG Aerosol Solution (filtered) ID AS04	made on 9/26/13	
Sampling P	13.4	13.4	psia	TSI APS, Model 3321	S/N 70907086	7/29/2014
Ambient pressure	1001	1000	mbar	N/A		
Ambient humidity	33.6%	32.8%	RH			
Ambient Temp	80.6	81.6	°F	Droplet Diameter: $D_d = (6Q/rtf)^{(1/3)}$		49.0 μm
VOAG Frequency	41.39	41.47	kHz			
VOAG Syringe Speed	4.6	4.6	$\times 10^{-4}$ cm/s	Aerosol concentration, C	0.0323	
VOAG Dispersion Air	10	10	cc/min x 100	Aerosol density, ρ	0.8929	
VOAG Dilution Air	70	70	LPM			
APS Mean AD	11.0	10.6	μm	Particle Diameter: $D_p = (C+I)^{(1/3)}D_d$		15.8 μm
APS Sig-G	1.183	1.213		Aerodynamic Diameter: $AD = D_p \cdot \text{SQRT}(\rho/1)$		14.9 μm
Notes: Turn on air flow ~13:18. Using bottom desiccant, dew point is around 4°F. Can deal with that until testing time... or rather, keep an eye on it as we increase humidity.						
* Humidity is not controlled by the chamber at this temperature.						
Switch to top desiccant at 13:34. Chamber is at 328°F and 5.5%RH at 13:37.						
Probably safest to stop at 6%RH (Conditioned air dew point is approaching dry bulb).						
13:42 increase chamber T from 328 to 365. Starting humidity is 6.2%.						
"New" desiccant is only -1°F dp at 13:45.						
13:50 increase heat tape to 315°F on Omega. 13:52 change that to 300°F.						
Chamber temperature is still oscillating around 365°F at start of test but since the humidity is conservative at 2%, started the VOAG. ~14:45 VOAG behavior got erratic, just a bit. Tweaked frequency.						
/						
Data Files						
Environmental Chamber Data:	130927_hvs3_max.csv					
FIO Vaisala Dew Point Data:	N/A					
FIO Alicat Data:	20130927_1315_alicat.dat					
FIO APS Data:	test_sept_27_2013_1_conc_mass.txt					
Entries made by:	Julia Flaherty			Technical Data Review performed by:	Carmen Arimescu	
Signature/date	On File w/ Original 9/27/2013			Signature/date	On File w/ Original 3/13/2014	

HIGH TEMPERATURE PROBE TESTING - Aerosol Penetration									
Fluorometry Data									
Run No.	AP-8			Facility	HV-S3				
Date	9/27/2013			Chamber Set Point	365°F / 1.5% RH *				
Start/End Time	10:30 / 16:05			Diluter Flows	Max Stack, Norm ISA				
Testers	JEF			Diluter Orientation	Mostly Vert				
Materials and Equipment Used:				Cal Due					
Turner Trilogy Fluorometer		S/N 720000895				N/A			
Sartorius QS 2000 Lab Balance		S/N 60502077				6/24/2014			
N/A									
Aerosol Wash Solution		ID AW10		Made on		9/20/2013			
Whatman AutoVial						N/A			
N/A									
		Wash Solution		Fluorescence				Aerosol	
	Sample	Mass (g)		1 - RFU	2 - RFU	3 - RFU	Mean	RFU/g	Penetration
Pre-Test Wash	Fittings	67.9		19.54	19.81	19.47	19.6	0.3	N/A
	Diluter	114.3		26.38	26.39	26.17	26.3	0.2	
	Solid Std	N/A		2555.71	2555.44	2555.30	2555.5		
	Solution Blank	N/A		7.95	7.92	7.92	7.9		
First Wash	Filter	94.6		6623.88	6658.53	6630.18	6637.5	70.2	0.9973
	Fittings	62.3		193.34	192.32	193.29	193.0	3.1	
	Diluter	139.6		27.70	28.05	28.19	28.0	0.2	
	Solid Std	N/A		2593.18	2593.46	2593.29	2593.3		
	Filter Blank	94.2		12.05	12.38	12.71	12.4	0.1	
	Solution Blank	N/A		8.12	8.30	8.36	8.3		
Second Wash	Filter	88.0		472.43	475.66	471.63	473.2	5.4	0.9961
	Fittings	62.4		17.86	18.49	18.21	18.2	0.3	
	Diluter	112.5		12.35	12.57	12.80	12.6	0.1	
	Solid Std	N/A		2545.06	2544.65	2544.53	2544.7		
	Filter Blank	84.4		13.04	13.43	13.07	13.2	0.2	
	Solution Blank	N/A		9.16	9.76	9.55	9.5		
Third Wash	Filter	82.9		215.23	215.10	215.87	215.4	2.6	0.9946
	Fittings	62.4		12.50	12.63	12.66	12.6	0.2	
	Diluter	100.4		13.33	13.59	13.66	13.5	0.1	
	Solid Std	N/A		2580.08	2581.38	2580.56	2580.7		
	Filter Blank	86.2		10.42	10.82	10.74	10.7	0.1	
	Solution Blank	N/A		9.71	9.60	9.68	9.7		
Notes: Used AutoVial for everything on the first wash, then only filters for 2nd and 3rd washes.									
Filter shows evidence of condensatio at some point in the prep / test.									
Not likely that it occurred during the VOAG period, but no definitive way to tell.									
* Humidity is not controlled by the chamber at this temperature.									
/									
Entries made by: Julia Flaherty			Technical Data Review performed by: Carmen Arimescu						
Signature/date: On File w/ Original 9/27/2013			Signature/date: On File w/ Original 3/13/2014						

HIGH TEMPERATURE PROBE TESTING - Aerosol Penetration						
Aerosol and Dilution Data						
Run No.	AP-9			Facility	HV-S3	
Date	10/9/2013			Chamber Set Point	365°F / 1.5% RH	
Start/End Time	5:25 / 5:55			Diluter Flows	Max Stack, Max ISA	
Testers	JEF			Diluter Orientation	Mostly Vert (21° from vert)	
	Start	Finish		Materials and Equipment Used:		Cal Due
Time	5:25	5:55		Thermotron SE-2000-4 Env Chamber S/N 42857		4/2/2014
Chamber Temp	365	365	°F	Alicat MCR-500SLPM MFC SN 68858		2/4/2014
Chamber Humidity	1.5%	1.5%	RH	Alicat MCR-500SLPM-D MFC SN 68857		4/3/2014
Dilution flowcontroller	7.63	7.63	scfm	Vaisala MI70/HMP77B S/N G5230040/H0320001		1/31/2014
Dilution Dew Pt	0	0	°F	Vaisala MI70/DMP74B S/N G5230040/H0320001		1/31/2014
Dilution Temp	77	76	°F	Type T Thermocouples T004 - T006, T008, T009		6/18/2014
Dilution P	15.1	15.1	psia	Mott Corp Diluter 32" OAL Model 7610S-1.375-24-2-AB		N/A
Sampling flowcontroller	8.34	8.34	scfm	Fisher Dew Point Pen S/N 122277883		5/16/2014
Sampling Dew Pt	69	69	°F	TSI VOAG, Model 345001 S/N 406		N/A
Sampling Temp	101	101	°F	VOAG Aerosol Solution ID AS03 made on 9/19/13		
Sampling P	13.3	13.3	psia	Hach OPC S/N 1011529010		3/7/2014
Ambient pressure	1000	1000	mbar	TSI APS, Model 3321 S/N 70907086		7/29/2014
Ambient humidity	27.9%	30.3%	RH			
Ambient Temp	81.5	80.9	°F	Droplet Diameter: $D_d = (6Q/πf)^{1/3}$		47.5 μm
VOAG Frequency	41.45	41.45	kHz			
VOAG Syringe Speed	4.2	4.2	x 10 ⁻⁴ cm/s	Aerosol concentration, C		0.0165
VOAG Dispersion Air	10	10	cc/min x 100	Aerosol density, ρ		0.8931
VOAG Dilution Air	70	70	LPM			
APS Mean AD	N/A	N/A	μm	Particle Diameter: $D_p = (C+I)^{1/3}D_d$		12.3 μm
APS Sig-G	N/A	N/A		Aerodynamic Diameter: $AD = D_p \cdot \sqrt{ρ/1}$		11.7 μm
Notes: Original, 9/30/13 Notes: ~9:30 turn on heat tape, set point = 300°F.						
~9:42 lost power to building momentarily, after a minute or so, chamber resumed operation. Everything else returned immediately. (except for the need to re-set heat tape)						
Turns out the power bump scrambled the thermocouple data acquisition - work with Thermotron to troubleshoot.						

Re-start test on 10/9. Set the humidity range to 370°F, so humidity is controlled. Included coated glass slides in chamber. APS is being strange, so the data are collected, but the Hach OPC will be used for sizing. The peak from the OPC was in the 13-15 μm bin...						
FYI: Thermocouple issues were resolved on its own at midnight on 9/30/13. No known reason for that.						
/						
Data Files						
Environmental Chamber Data:	131009_hvs3_max.csv					
FIO Vaisala Dew Point Data:	2013-10-09 16_03.csv					
FIO Alicat Data:	20131009_1549_alicat.dat					
FIO APS Data:	test_oct_09_2013_1.A21					
FIO Hach Data:	Hach_OPC_131009_AP9.xlsx					
Entries made by:	Julia Flaherty			Technical Data Review performed by:	Carmen Arimescu	
Signature/date	On File w/ Original 10/9/2013			Signature/date	On File w/ Original 3/13/2014	

HIGH TEMPERATURE PROBE TESTING - Aerosol Penetration									
Fluorometry Data									
Run No.	AP-9				Facility	HV-S3			
Date	9/30 - 10/10/13				Chamber Set Point	365°F / 1.5% RH			
Start/End Time	8:55 - 4:30				Diluter Flows	Max Stack, Max ISA			
Testers	JEF				Diluter Orientation	Mostly Vert (21° from vert)			
Materials and Equipment Used:					Cal Due				
Turner Trilogy Fluorometer			S/N 720000895		N/A				
Sartorius QS 2000 Lab Balance			S/N 60502077		6/24/2014				
N/A									
Aerosol Wash Solution			ID AW11		Made on 9/30/2013				
Whatman AutoVial			N/A						
N/A									
		Wash Solution			Fluorescence				Aerosol Penetration
	Sample	Mass (g)	1 - RFU	2 - RFU	3 - RFU	Mean	RFU/g		
Pre-Test Wash	Fittings	59.4	20.25	22.16	20.39	20.9	0.4	N/A	
	Diluter	122.7	22.18	21.80	21.77	21.9	0.2		
	Solid Std	N/A	2516.65	2516.37	2516.35	2516.5			
	Solution Blank	N/A	9.30	9.40	9.42	9.4			
First Wash	Filter	103.7	4718.18	4732.79	4732.24	4727.7	45.6	0.9853	
	Fittings	66.9	76.96	77.20	77.39	77.2	1.2		
	Diluter	150.5	104.35	104.86	105.75	105.0	0.7		
	Solid Std	N/A	2585.30	2584.24	2584.08	2584.5			
	Filter Blank	101.2	13.74	13.76	13.66	13.7	0.1		
	Solution Blank	N/A	8.13	8.05	8.18	8.1			
Second Wash	Filter	72.3	1153.89	1158.18	1153.38	1155.2	16.0	0.9841	
	Fittings	68.3	32.92	35.45	33.69	34.0	0.5		
	Diluter	99.1	35.02	31.09	30.68	32.3	0.3		
	Solid Std	N/A	2578.78	2578.53	2579.27	2578.9			
	Filter Blank	76.3	11.67	14.02	11.70	12.5	0.2		
	Solution Blank	N/A	8.17	8.26	8.22	8.2			
Third Wash	Filter	63.9	200.43	200.76	200.02	200.4	3.1	0.9822	
	Fittings	63.7	18.10	18.23	18.31	18.2	0.3		
	Diluter	120.3	22.47	22.54	22.55	22.5	0.2		
	Solid Std	N/A	2577.82	2579.04	2580.47	2579.1			
	Filter Blank	59.4	12.01	11.71	12.58	12.1	0.2		
	Solution Blank	N/A	8.55	8.54	8.70	8.6			
<p>Notes: Instrument troubles caused a delay in testing. Resumed w/ VOAG & Hach OPC on 10/9/13. Pre-test wash performed on 9/30/13.</p> <p>Used AutoVial for everything on 1st wash, then only filters on 2nd & 3rd washes. Only enough AutoVials for this test.</p> <p>Filter has a yellow region on it. Small bit left after 1st wash. Pretty clear after 2nd wash, although the filter was a bit broken up.</p>									
/									
Entries made by:	Julia Flaherty				Technical Data Review performed by:	Carmen Arimescu			
Signature/date	On File w/ Original			10/10/2013	Signature/date	On File w/ Original			3/13/2014

HIGH TEMPERATURE PROBE TESTING - Aerosol Penetration						
Aerosol and Dilution Data						
Run No.	AP-10			Facility	HV-S3	
Date	10/16/2013			Chamber Set Point	73.5°F / 35% RH	
Start/End Time	15:45 / 16:15			Diluter Flows	Norm stack, Norm ISA	
Testers	JEF			Diluter Orientation	Mostly Vert (21° from vert)	
	Start	Finish		Materials and Equipment Used:		Cal Due
Time	15:45	16:15		Thermotron SE-2000-4 Env Chamber S/N 42857		4/2/2014
Chamber Temp	73.5	73.5	°F	Alicat MCR-500SLPM MFC SN 68858		2/4/2014
Chamber Humidity	34.0%	34.9%	RH	Alicat MCR-500SLPM-D MFC SN 68857		4/3/2014
Dilution flowcontroller	4.07	4.07	scfm	Vaisala MI70/HMP77B S/N G5230040/H0320001		1/31/2014
Dilution Dew Pt	1.5	1.0	°F	Vaisala MI70/DMP74B S/N G5230040/H0320001		1/31/2014
Dilution Temp	79.7	80.5	°F	Type T Thermocouples T004 - T006, T008, T009		6/18/2014
Dilution P	14.9	14.8	psia	Mott Corp Diluter 32" OAL Model 7610S-1.375-24-2-AB		N/A
Sampling flowcontroller	4.88	4.88	scfm	Fisher Dew Point Pen S/N 122277883		5/16/2014
Sampling Dew Pt	26.8	11.9	°F	TSI VOAG, Model 345001 S/N 406		N/A
Sampling Temp	69.6	77.8	°F	VOAG Aerosol Solution (filtered) ID AS03 made on 9/19/13		
Sampling P	14.1	14.1	psia	Hach OPC S/N 1011529010		8/7/2014
Ambient pressure	1006	1006	mbar	TSI APS, Model 3321 S/N 70907086		7/29/2014
Ambient humidity	24.9%	23.6%	RH			
Ambient Temp	77.5	79.9	°F	Droplet Diameter: $Dd = (6Q/πf)^{(1/3)}$		47.5 μm
VOAG Frequency	41.48	41.46	kHz			
VOAG Syringe Speed	4.2	4.2	x 10 ⁻⁴ cm/s	Aerosol concentration, C		0.0165
VOAG Dispersion Air	10	10	cc/min x 100	Aerosol density, ρ		0.8931
VOAG Dilution Air	70	70	LPM			
APS Mean AD	9.31	9.02	μm	Particle Diameter: $Dp = (C+)^{(1/3)}Dd$		12.3 μm
APS Sig-G	1.118	1.130		Aerodynamic Diameter: $AD = Dp * SQRT(ρ/1)$		11.7 μm
Notes: Placed glass slides w/ electronic grade coating in the chamber to collect particles. Slides numbered 26 & 27.						
Room air test with no heat tape.						
Use Hach and TSI to measure aerosol size. They are nominally sync'd to collect samples at the same time.						
Checked aerosol injection probe prior to setting the chamber set point. Before starting aerosol injection, tried to check probe through the window, but can't see it. After test, observe outlet of the injection probe is external to the flex duct.						
Bummer...						
/						
JF 10/16/13						
Data Files						
Environmental Chamber Data: 131016_hvs3_room_air.csv						
FIO Vaisala Dew Point Data: 2013_10_16_15_52.csv						
FIO Alicat Data: 20131016_1539_alicat.dat						
FIO APS Data: test_oct_16_2013_1_conc_num.txt						
FIO Hach Data: Hach_OPC_131016_AP10.xlsx						
Entries made by:	Julia Flaherty			Technical Data Review performed by:	Carmen Arimescu	
Signature/date	On File w/ Original 10/16/2013			Signature/date	On File w/ Original 3/13/2014	

HIGH TEMPERATURE PROBE TESTING - Aerosol Penetration									
Fluorometry Data									
Run No.	AP-10			Facility	HV-S3				
Date	10/16/2013			Chamber Set Point	73.5°F / 35% RH				
Start/End Time	14:25 / 17:05			Diluter Flows	Norm Stack, Norm ISA				
Testers	JEF			Diluter Orientation	Mostly Vert (21° from vert)				
Materials and Equipment Used:				Cal Due					
Turner Trilogy Fluorometer		S/N 720000895		N/A					
Sartorius QS 2000 Lab Balance		S/N 60502077		6/24/2014					
N/A									
Aerosol Wash Solution		ID AW11		Made on 9/30/2013					
Fisherbrand PTFE 0.45 um filters		N/A							
Terumo 3 cc syringe		N/A							
	Wash Solution			Fluorescence				Aerosol	
	Sample	Mass (g)	1 - RFU	2 - RFU	3 - RFU	Mean	RFU/g	Penetration	
Pre-Test Wash	Fittings	79.7	17.35	17.69	18.35	17.8	0.2	N/A	
	Diluter	131.2	24.37	24.30	24.49	24.4	0.2		
	Solid Std	N/A	2378.60	2378.23	2378.24	2378.4			
	Solution Blank	N/A	7.77	8.06	8.88	8.2			
First Wash	Filter	103.9	20.65	20.97	22.35	21.3	0.2	0.8382	
	Fittings	63.6	21.43	21.23	21.46	21.4	0.3		
	Diluter	143.6	14.95	15.06	15.01	15.0	0.1		
	Solid Std	N/A	2579.34	2578.87	2578.64	2579.0			
	Filter Blank	97.1	9.63	9.61	9.92	9.7	0.1		
	Solution Blank	N/A	8.54	8.45	8.48	8.5			
Second Wash	Filter					#DIV/0!	#DIV/0!	#DIV/0!	
	Fittings					#DIV/0!	#DIV/0!		
	Diluter					#DIV/0!	#DIV/0!		
	Solid Std	N/A				#DIV/0!			
	Filter Blank		JF 10/16/13				#DIV/0!		#DIV/0!
	Solution Blank	N/A					#DIV/0!		
Third Wash	Filter					#DIV/0!	#DIV/0!	#DIV/0!	
	Fittings					#DIV/0!	#DIV/0!		
	Diluter					#DIV/0!	#DIV/0!		
	Solid Std	N/A				#DIV/0!			
	Filter Blank						#DIV/0!		#DIV/0!
	Solution Blank	N/A					#DIV/0!		
Notes: First wash included a wash of the back half of the filter holder.									
41.7g		49.95	49.69	49.84 RFU	Mean =	49.83	1.19 RFU/g		
Abandon fluorescence measurements after 1st wash. Not much aerosol made it through. I've got bad luck with room air tests. The aerosol injection probe was positioned correctly at start of test, but checking it afterwards, the probe outlet is external to the flex duct. Try this again...									
JF 10/16/13									
Entries made by:	Julia Flaherty			Technical Data Review performed by:		Carmen Arimescu			
Signature/date	On File w/ Original		10/16/2013	Signature/date		On File w/ Original		3/13/2014	

HIGH TEMPERATURE PROBE TESTING - Aerosol Penetration						
Aerosol and Dilution Data						
Run No.	AP-11			Facility	HV-S3	
Date	10/17/2013			Chamber Set Point	73.5°F / 35% RH	
Start/End Time	11:15 / 12:04			Diluter Flows	Norm stack, Norm ISA	
Testers	JEF			Diluter Orientation	Mostly Vert (21° from vert)	
	Start	Finish		Materials and Equipment Used:		Cal Due
Time	11:15	12:04		Thermotron SE-2000-4 Env Chamber S/N 42857		4/2/2014
Chamber Temp	73.5	73.5	°F	Alicat MCR-500SLPM MFC SN 68858		2/4/2014
Chamber Humidity	35.0%	34.9%	RH	Alicat MCR-500SLPM-D MFC SN 68857		4/3/2014
Dilution flowcontroller	4.07	4.07	scfm	Vaisala MI70/HMP77B S/N G5230040/H0320001		1/31/2014
Dilution Dew Pt	0.0	0.0	°F	Vaisala MI70/DMP74B S/N G5230040/H0320001		1/31/2014
Dilution Temp	76.8	79.8	°F	Type T Thermocouples T004 - T006, T008, T009		6/18/2014
Dilution P	15.0	15.0	psia	Mott Corp Diluter 32" OAL Model 7610S-1.375-24-2-AB		N/A
Sampling flowcontroller	4.88	4.88	scfm	Fisher Dew Point Pen S/N 122277883		5/16/2014
Sampling Dew Pt	12	3.5	°F	TSI VOAG, Model 345001 S/N 406		N/A
Sampling Temp	74	78	°F	VOAG Aerosol Solution (filtered) ID AS04 made on 9/26/13		
Sampling P	14.2	14.2	psia	Hach OPC S/N 1011529010		8/7/2014
Ambient pressure	1011	1011	mbar	TSI APS, Model 3321 S/N 70907086		7/29/2014
Ambient humidity	25.7%	24.8%	RH			
Ambient Temp	78.9	81.9	°F	Droplet Diameter: $Dd = (6Q/πf)^{1/3}$		47.5 μm
VOAG Frequency	41.47	41.46	kHz			
VOAG Syringe Speed	4.2	4.2	x 10 ⁻⁴ cm/s	Aerosol concentration, C		0.0323
VOAG Dispersion Air	10	10	cc/min x 100	Aerosol density, ρ		0.8929
VOAG Dilution Air	70	70	LPM			
APS Mean AD	10.7	11.0	μm	Particle Diameter: $Dp = (C+)^{1/3}Dd$		15.3 μm
APS Sig-G	1.209	1.170		Aerodynamic Diameter: $AD = Dp \cdot \sqrt{ρ}/1$		14.4 μm
Notes: Chamber humidity was not particularly stable during the course of this test.						
Room temperature test, so no heat tapes were used.						
Two glass slides with electronic grade coating were placed in the chamber under the shrouded probe / flex duct.						
Slides numbered 28 & 29.						
Checked the flex duct position at start of test, and added duct tape for extra security. Flex duct remained in place during test.						
/						
JF 10/17/13						
Data Files						
Environmental Chamber Data:		131017_hvs3_room_air.csv				
FIO Vaisala Dew Point Data:		2013_10_17_11_06.csv				
FIO Alicat Data:		20131017_1052_alicat.dat				
FIO APS Data:		test_oct_17_2013_1_conc_num.txt				
FIO Hach Data:		Hach_OPC_131017_AP11.xlsx				
Entries made by:	Julia Flaherty			Technical Data Review performed by:	Carmen Arimescu	
Signature/date	On File w/ Original 10/17/2013			Signature/date	On File w/ Original 3/13/2014	

HIGH TEMPERATURE PROBE TESTING - Aerosol Penetration									
Fluorometry Data									
Run No.	AP-11			Facility	HV-S3				
Date	10/17/2013			Chamber Set Point	73.5°F / 35% RH				
Start/End Time	9:50 / 16:00			Diluter Flows	Norm Stack, Norm ISA				
Testers	JEF			Diluter Orientation	Mostly Vert (21° from vert)				
Materials and Equipment Used:				Cal Due					
Turner Trilogy Fluorometer		S/N 720000895		N/A					
Sartorius QS 2000 Lab Balance		S/N 60502077		6/24/2014					
N/A									
Aerosol Wash Solution		ID AW11		Made on 9/30/2013					
Fisherbrand PTFE 0.45 um filters		N/A							
Terumo 3 cc syringe		N/A							
	Wash Solution			Fluorescence				Aerosol Penetration	
	Sample	Mass (g)		1 - RFU	2 - RFU	3 - RFU	Mean	RFU/g	
Pre-Test Wash	Fittings	64.7		26.83	27.10	26.75	26.9	0.4	
	Diluter	115.8		22.47	22.58	22.62	22.6	0.2	N/A
	Solid Std	N/A		2570.80	2570.06	2569.90	2570.3		
	Solution Blank	N/A		9.19	9.59	9.69	9.5		
First Wash	Filter	93.5		475.15	473.30	474.66	474.4	5.1	
	Fittings	52.9		547.32	547.71	549.39	548.1	10.4	0.9733
	Diluter	125.0		53.03	52.66	52.82	52.8	0.4	
	Solid Std	N/A		2590.61	2591.22	2591.05	2591.0		
	Filter Blank	90.3		9.61	9.63	9.59	9.6	0.1	
	Solution Blank	N/A		10.97	10.93	10.85	10.9		
Second Wash	Filter	76.1		15.87	15.86	15.86	15.9	0.2	
	Fittings	70.5		25.60	25.44	25.31	25.5	0.4	0.9583
	Diluter	119.3		32.64	32.63	32.50	32.6	0.3	
	Solid Std	N/A		2586.59	2584.86	2584.34	2585.3		
	Filter Blank	78.9		8.29	8.34	8.35	8.3	0.1	
	Solution Blank	N/A		10.67	10.69	10.70	10.7		
Third Wash	Filter	68.8		9.75	9.74	9.84	9.8	0.1	
	Fittings	55.4		23.78	23.78	24.00	23.9	0.4	0.9505
	Diluter	111.3		18.71	18.56	18.90	18.7	0.2	
	Solid Std	N/A		2477.70	2478.05	2477.54	2477.8		
	Filter Blank	62.5		8.27	8.18	8.16	8.2	0.1	
	Solution Blank	N/A		12.79	12.81	12.62	12.7		
Notes: Back half of filter holder (1st wash)									
45.8g 30.31 30.32 30.33 RFU (AVG=30.32 RFU, 0.66 RFU/g)									
Used a 3 cc syringe w/ a syringe filter to dispense sample from 1st wash, then only the filter samples (4" filter, filter blank) for the 2nd and 3rd washes.									
FYI: JAG visit during 2nd wash.									
Note the distribution of fluorescence readings in the first wash: nearly 50/50 between Filter & Fittings. Check back thru the data; I suspect this is unique for HV-S3 testing, and may be more similar to LV-S3 test results (some, at least).									
/									
Entries made by:	Julia Flaherty			Technical Data Review performed by:			Carmen Arimescu		
Signature/date	On File w/ Original 10/17/2013			Signature/date			On File w/ Original 3/13/2014		

HIGH TEMPERATURE PROBE TESTING - Aerosol Penetration						
Aerosol and Dilution Data						
Run No.	AP-12			Facility	HV-S3	
Date	10/23/2013			Chamber Set Point	73.5°F / 35% RH	
Start/End Time	10:10 / 11:00			Diluter Flows	Norm stack, Norm ISA	
Testers	JEF			Diluter Orientation	Mostly Vert (20° from vert)	
	Start	Finish		Materials and Equipment Used:		Cal Due
Time	10:10	11:00		Thermotron SE-2000-4 Env Chamber S/N 42857		4/2/2014
Chamber Temp	73.5	73.5	°F	Alicat MCR-500SLPM MFC	SN 68858	2/4/2014
Chamber Humidity	33.6%	35.1%	RH	Alicat MCR-500SLPM-D MFC	SN 68857	4/3/2014
Dilution flowcontroller	4.07	4.07	scfm	Vaisala MI70/HMP77B	S/N G5230040/H0320001	1/31/2014
Dilution Dew Pt	0.0	-2.0	°F	Vaisala MI70/DMP74B	S/N G5230040/H0320001	1/31/2014
Dilution Temp	72.5	76.4	°F	Type T Thermocouples	T004 - T006, T008, T009	6/18/2014
Dilution P	14.9	14.9	psia	Mott Corp Diluter 32" OAL	Model 7610S-1.375-24-2-AB	N/A
Sampling flowcontroller	4.88	4.88	scfm	Fisher Dew Point Pen	S/N 122277883	5/16/2014
Sampling Dew Pt	30.2	10.3	°F	TSI VOAG, Model 345001	S/N 406	N/A
Sampling Temp	64.7	75.5	°F	VOAG Aerosol Solution (filtered)	ID AS04 made on 9/26/13	
Sampling P	14.1	14.1	psia	Hach OPC	S/N 1011529010	3/7/2014
Ambient pressure	1006	1006	mbar	TSI APS, Model 3321	S/N 70907086	7/29/2014
Ambient humidity	29.5%	28.1%	RH			
Ambient Temp	74.8	78.4	°F	Droplet Diameter: $Dd = (6Q/rtf)^{1/3}$		47.5 μm
VOAG Frequency	41.50	41.49	kHz			
VOAG Syringe Speed	4.2	4.2	x 10 ⁻⁴ cm/s		Aerosol concentration, C	0.0323
VOAG Dispersion Air	10	10	cc/min x 100		Aerosol density, ρ	0.8929
VOAG Dilution Air	60	60	LPM			
APS Mean AD	10.8	10.3	μm	Particle Diameter: $Dp = (C+I)^{1/3}Dd$		15.3 μm
APS Sig-G	1.174	1.283		Aerodynamic Diameter: $AD = Dp \cdot \text{SQRT}(\rho/1)$		14.4 μm
Notes: Room temperature test, so no heat tapes are used.						
Glass slides that were washed and coated in electronic grade coating (oleophobic) yesterday are placed in the bottom of the chamber below the flex duct. Slides numbered 30 & 31.						
Started MFC's ~10:00.						
The chamber doesn't appear to want to stabilize in the humidity set point. At 10:50 (2 hrs since the chamber set point was established), it finally looks like the humidity may stabilize.						
During the course of the test, the APS showed some periods of noisy particle size. The size distribution was pretty "clean" at the start and finish, but not necessarily for the duration.						
FYI: Double-checked flex duct / duct tape at start of test.						
Data Files						
Environmental Chamber Data:	131023_hvs3_room_air.csv					
FIO Vaisala Dew Point Data:	2013-10-23 10_11.csv					
FIO Alicat Data:	20131023_0959_alicat.dat					
FIO APS Data:	test_oct_23_2013_1_conc_mass.txt					
FIO Hach Data:	N/A					
Entries made by:	Julia Flaherty			Technical Data Review performed by:	Carmen Arimescu	
Signature/date	On File w/ Original 10/23/2013			Signature/date	On File w/ Original 3/13/2014	

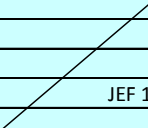
HIGH TEMPERATURE PROBE TESTING - Aerosol Penetration								
Fluorometry Data								
Run No.	AP-12			Facility	HV-S3			
Date	10/23/2013			Chamber Set Point	73.5°F / 35% RH			
Start/End Time	9:00 / 12:00			Diluter Flows	Norm Stack, Norm ISA			
Testers	JEF			Diluter Orientation	Mostly Vert (20° from vert)			
Materials and Equipment Used:				Cal Due				
Turner Trilogy Fluorometer		S/N 720000895		N/A				
Sartorius QS 2000 Lab Balance		S/N 60502077		6/24/2014				
N/A								
Aerosol Wash Solution		ID AW12		Made on 10/21/2013				
Fisherbrand PTFE 0.45 um filters		N/A						
Terumo 3 cc syringe		N/A						
	Wash Solution		Fluorescence				RFU/g	Aerosol Penetration
	Sample	Mass (g)	1 - RFU	2 - RFU	3 - RFU	Mean		
Pre-Test Wash	Fittings	74.6	13.99	14.19	13.81	14.0	0.2	N/A
	Diluter	130.2	15.67	18.67	15.32	16.6	0.1	
	Solid Std	N/A	2559.77	2559.75	2559.71	2559.7		
	Solution Blank	N/A	8.79	8.71	8.72	8.7		
First Wash	Filter	94.4	20.50	20.35	20.38	20.4	0.2	0.8173
	Fittings	82.4	18.30	18.37	18.35	18.3	0.2	
	Diluter	136.4	13.32	13.34	13.47	13.4	0.1	
	Solid Std	N/A	2580.07	2579.94	2579.35	2579.8		
	Filter Blank	94.6	10.46	10.50	10.44	10.5	0.1	
	Solution Blank	N/A	8.98	8.95	8.92	9.0		
Second Wash	Filter					#DIV/0!	#DIV/0!	#DIV/0!
	Fittings					#DIV/0!	#DIV/0!	
	Diluter					#DIV/0!	#DIV/0!	
	Solid Std	N/A				#DIV/0!		
	Filter Blank					#DIV/0!	#DIV/0!	
	Solution Blank	N/A		JF 10/23/13			#DIV/0!	
Third Wash	Filter					#DIV/0!	#DIV/0!	#DIV/0!
	Fittings					#DIV/0!	#DIV/0!	
	Diluter					#DIV/0!	#DIV/0!	
	Solid Std	N/A				#DIV/0!		
	Filter Blank					#DIV/0!	#DIV/0!	
	Solution Blank	N/A					#DIV/0!	
Notes: Use syringe filters for all the 1st wash samples, then only for the filters on 2nd & 3rd washes. Diluter sample (in vial) had some small black flecks and a grey/brown floaty. So a pipette was used to pull the top half of the vial into a new vial for a clean sample. This is another room temp test with a pretty poor fluorescence outcome. Skip 2nd and 3rd washes.								
 JEF 10/23/13								
Entries made by:	Julia Flaherty			Technical Data Review performed by:	Carmen Arimescu			
Signature/date	On File w/ Original 10/23/2013			Signature/date	On File w/ Original 3/13/2014			

HIGH TEMPERATURE PROBE TESTING - Aerosol Penetration						
Aerosol and Dilution Data						
Run No.	AP-13			Facility	HV-S3	
Date	10/29/2013			Chamber Set Point	73.5°F / 35% RH	
Start/End Time	1:26 / 2:06			Diluter Flows	Norm stack, Norm ISA	
Testers	JEF			Diluter Orientation	Mostly Vert	
	Start	Finish		Materials and Equipment Used:		Cal Due
Time	1:26	2:06		Thermotron SE-2000-4 Env Chamber S/N 42857		4/2/2014
Chamber Temp	73.5	73.5	°F	Alicat MCR-500SLPM MFC SN 68858		2/4/2014
Chamber Humidity	36.0%	35.0%	RH	Alicat MCR-500SLPM-D MFC SN 68857		4/3/2014
Dilution flowcontroller	4.07	4.07	scfm	Vaisala MI70/HMP77B S/N G5230040/H0320001		1/31/2014
Dilution Dew Pt	3.9	2.7	°F	Vaisala MI70/DMP74B S/N G5230040/H0320001		1/31/2014
Dilution Temp	76.1	79.3	°F	Type T Thermocouples T004 - T006, T008, T009		6/18/2014
Dilution P	14.8	14.8	psia	Mott Corp Diluter 32" OAL Model 7610S-1.375-24-2-AB		N/A
Sampling flowcontroller	4.88	4.88	scfm	Fisher Dew Point Pen S/N 122277883		5/16/2014
Sampling Dew Pt	11	11	°F	TSI VOAG, Model 345001 S/N 406		N/A
Sampling Temp	75	78	°F	VOAG Aerosol Solution (filtered) ID AS04 made on 9/26/13		
Sampling P	13.7	13.7	psia	Hach OPC SN 1011529010		3/7/2014
Ambient pressure	1003	1003	mbar	TSI APS, Model 3321 S/N 70907086		7/29/2014
Ambient humidity	16.1%	16.2%	RH			
Ambient Temp	78.7	80.9	°F	Droplet Diameter: $D_d = (6Q/rtf)^{(1/3)}$		47.5 μm
VOAG Frequency	41.49	41.48	kHz			
VOAG Syringe Speed	4.2	4.2	$\times 10^{-4}$ cm/s	Aerosol concentration, C		0.0323
VOAG Dispersion Air	10	10	cc/min $\times 100$	Aerosol density, ρ		0.8929
VOAG Dilution Air	60	60	LPM			
APS Mean AD	12.5	11.9	μm	Particle Diameter: $D_p = (C+)^{(1/3)}D_d$		15.3 μm
APS Sig-G	1.154	1.193		Aerodynamic Diameter: $AD = D_p \cdot \text{SQRT}(\rho/1)$		14.4 μm
Notes: Use top desiccant system. Drained ~50 cc at 12:35.						
Bit of paper taped to shroud are used to verify flow out of flex duct.						
This test will include a measure of the filter/filter holder efficiency, with a second filter holder downstream of the usual filter holder. About 40cc of AS04 is left. Will need to mix more soon.						
Turned on chamber at ~12:30. Let it run a bit to stabilize humidity.						
When measured directly from the VOAG output, the AS04 particle size distribution was somewhat broad (~6 bins) and mean was 11.4 μm and dropping. At start of test, measured through the tee, the mean was higher and very narrow 2 bins.						
Odd, but I'll go with it.						
1:37 the mean dropped a bit to 12.1 μm , with 3 bins.						
Also, the humidity is still oscillating a bit.						
The aerosol size distribution varied quite a bit during this test. Most times look okay, but occasionally looked terrible.						
<hr/>						
<i>Data Files</i>						
Environmental Chamber Data: 131029_hvs3_room_air.csv						
FIO Vaisala Dew Point Data: 2013-10-29_13_53.csv (recording started at 1:40)						
FIO Alicat Data: 20131029_1316_alicat.dat						
FIO APS Data: test_oct_29_2013_1_conc_mass.txt						
FIO Hach Data: N/A						
<hr/>						
Entries made by:	Julia Flaherty			Technical Data Review performed by:	Carmen Arimescu	
Signature/date	On File w/ Original 10/29/2013			Signature/date	On File w/ Original 3/13/2014	

HIGH TEMPERATURE PROBE TESTING - Aerosol Penetration									
Fluorometry Data									
Run No.	AP-13			Facility	HV-S3				
Date	10/29/2013 - 10/30/2013			Chamber Set Point	73.5°F / 35% RH				
Start/End Time	11:25 / 9:25			Diluter Flows	Norm Stack, Norm ISA				
Testers	JEF			Diluter Orientation	Mostly Vert				
Materials and Equipment Used:				Cal Due					
Turner Trilogy Fluorometer		S/N 720000895		N/A					
Sartorius QS 2000 Lab Balance		S/N 60502077		6/24/2014					
N/A									
Aerosol Wash Solution		ID AW12		Made on 10/21/2013					
Whatman AutoVial (PTFE filter media)				N/A					
N/A				N/A					
	Wash Solution		Fluorescence					Aerosol Penetration	
	Sample	Mass (g)	1 - RFU	2 - RFU	3 - RFU	Mean	RFU/g		
Pre-Test Wash	Fittings	51.1	38.61	38.64	39.00	38.8	0.8	N/A	
	Diluter	114.2	23.16	21.16	21.38	21.9	0.2		
	Solid Std	N/A	2564.53	2565.34	2565.05	2565.0			
	Solution Blank	N/A	9.37	9.38	9.45	9.4			
First Wash	Filter	73.6	2252.21	2261.04	2252.92	2255.4	30.6	0.9876	
	Fittings	53.6	1858.61	1856.04	1862.46	1859.0	34.7		
	Diluter	126.6	104.06	104.15	104.49	104.2	0.8		
	Solid Std	N/A	2567.55	2567.34	2567.35	2567.4			
	Filter Blank	71.3	11.62	11.87	11.64	11.7	0.2		
	Solution Blank	N/A	11.90	11.76	11.76	11.8			
Second Wash	Filter	62.1	66.57	66.68	66.20	66.5	1.1	0.9855	
	Fittings	52.9	94.95	95.18	95.25	95.1	1.8		
	Diluter	121.1	22.13	22.08	22.01	22.1	0.2		
	Solid Std	N/A	2576.91	2576.40	2576.40	2576.6			
	Filter Blank	63.3	10.79	10.64	10.68	10.7	0.2		
	Solution Blank	N/A	13.77	13.79	13.91	13.8			
Third Wash	Filter	63.2	30.48	30.04	30.47	30.3	0.5	0.9838	
	Fittings	55.9	43.12	42.46	42.88	42.8	0.8		
	Diluter	119.9	16.74	16.64	16.63	16.7	0.1		
	Solid Std	N/A	2417.29	2418.26	2418.07	2417.9			
	Filter Blank	62.3	10.13	12.60	9.74	10.8	0.2		
	Solution Blank	N/A	15.74	15.24	15.29	15.4			
Notes: Include a filter efficiency check with this test. Two filter holders, which adds two more washes: 2nd fittings & 2nd filter.									
Pre-Test wash of fittings #2: 63.5g 24.82, 25.69, 24.72 RFU									
1st wash Fittings #2 66.0g 35.97, 35.68, 36.00 RFU									
Filter #2 70.8g 12.88, 12.76, 13.06 RFU									
Used AutoVial for 1st wash all. Since fittings #2 and filter #2 fluorescence numbers are pretty low, skip the 2nd and 3rd washes for these.									
Used AutoVial for filters on 2nd & 3rd washes.									
Entries made by:		Julia Flaherty			Technical Data Review performed by:		Carmen Arimescu		
Signature/date		On File w/ Original 10/30/2013			Signature/date		On File w/ Original 3/13/2014		

HIGH TEMPERATURE PROBE TESTING - Aerosol Penetration						
Aerosol and Dilution Data						
Run No.	AP-14			Facility	HV-S3	
Date	11/5/2013			Chamber Set Point	73.5°F / 35% RH	
Start/End Time	9:35 - 10:15			Diluter Flows	Max stack, norm ISA	
Testers	JEF			Diluter Orientation	Mostly Vert (22° from vert)	
	Start	Finish		Materials and Equipment Used:		Cal Due
Time	9:35	10:15		Thermotron SE-2000-4 Env Chamber S/N 42857		4/2/2014
Chamber Temp	73.6	73.5	°F	Alicat MCR-500SLPM MFC	SN 68858	2/4/2014
Chamber Humidity	30.6%	35.0%	RH	Alicat MCR-500SLPM-D MFC	SN 68857	4/3/2014
Dilution flowcontroller	7.42	7.42	scfm	Vaisala MI70/HMP77B	S/N G5230040/H0320001	1/31/2014
Dilution Dew Pt	-1.5	-8.7	°F	Vaisala MI70/DMP74B	S/N G5230040/H0320001	1/31/2014
Dilution Temp	74.1	72.7	°F	Type T Thermocouples	T004 - T006, T008, T009	6/18/2014
Dilution P	15.2	15.2	psia	Mott Corp Diluter 32" OAL	Model 7610S-1.375-24-2-AB	N/A
Sampling flowcontroller	8.13	8.13	scfm	Fisher Dew Point Pen	S/N 122277883	5/16/2014
Sampling Dew Pt	6	-2	°F	TSI VOAG, Model 345001	S/N 406	N/A
Sampling Temp	71	74	°F	VOAG Aerosol Solution (filtered)	ID AS04	made on 9/26/13
Sampling P	12.9	12.9	psia	Hach OPC	S/N 1014529040	3/7/2014
Ambient pressure	1006	1007	mbar	TSI APS, Model 3321	S/N 70907086	7/29/2014
Ambient humidity	22.9%	23.7%	RH			
Ambient Temp	75.9	77.1	°F	Droplet Diameter: $Dd = (6Q/πf)^{1/3}$		47.5 μm
VOAG Frequency	41.49	41.49	kHz			
VOAG Syringe Speed	4.2	4.2	x 10 ⁻⁴ cm/s		Aerosol concentration, C	0.0323
VOAG Dispersion Air	10	10	cc/min x 100		Aerosol density, ρ	0.8929
VOAG Dilution Air	60	60	LPM			
APS Mean AD	11.0	9.89	μm	Particle Diameter: $Dp = (C+)^{1/3}Dd$		15.3 μm
APS Sig-G	1.191	1.167		Aerodynamic Diameter: $AD = Dp \cdot \sqrt{ρ/1}$		14.4 μm
Notes: This is a "mostly vert" repeat of the less-than-satisfactory AP-2 test, which was horizontal.						
9:29 noticed that the flex duct had fallen off the injection probe. Fixed.						
APS particle size distribution looks generally good through the test.						
Fittings btwn the transport line elbow& diluter and btwn the ISA line & ISA tee were pretty tight - AKA mis-aligned.						
/						
JEF 11/5/13						
Data Files						
Environmental Chamber Data:	131105_hvs3_room_air.csv					
FIO Vaisala Dew Point Data:	2013-11-05 10_40.csv					
FIO Alicat Data:	20131105_1026_alicat.dat					
FIO APS Data:	test_nov_05_2013_1_conc_mass.txt					
FIO Hach Data:	N/A					
Entries made by:	Julia Flaherty			Technical Data Review performed by:	Carmen Arimescu	
Signature/date	On File w/ Original 11/5/2013			Signature/date	On File w/ Original 3/13/2014	

HIGH TEMPERATURE PROBE TESTING - Aerosol Penetration									
Fluorometry Data									
Run No.	AP-14			Facility	HV-S3				
Date	11/5/2013			Chamber Set Point	73.5°F / 35% RH				
Start/End Time	8:25 - 11:20			Diluter Flows	Max Stack, Norm ISA				
Testers	JEF			Diluter Orientation	Mostly Vert (22° from vert)				
Materials and Equipment Used:				Cal Due					
Turner Trilogy Fluorometer		S/N 720000895						N/A	
Sartorius QS 2000 Lab Balance		S/N 60502077						6/24/2014	
N/A								N/A	
Aerosol Wash Solution		ID AW13						Made on 11/1/2013	
Whatman AutoVial (PTFE filter media)								N/A	
N/A								N/A	
		Wash Solution		Fluorescence				Aerosol Penetration	
	Sample	Mass (g)		1 - RFU	2 - RFU	3 - RFU	Mean	RFU/g	
Pre-Test Wash	Fittings	58.8		24.02	23.98	24.09	24.0	0.4	
	Diluter	128.6		21.21	21.27	20.76	21.1	0.2	N/A
	Solid Std	N/A		2572.97	2572.79	2572.69	2572.8		
	Solution Blank	N/A		7.83	7.99	8.05	8.0		
First Wash	Filter	63		368.59	370.13	365.08	367.9	5.8	
	Fittings	57.4		2297.09	2284.53	2301.81	2294.5	40.0	0.9844
	Diluter	123.5		89.60	89.98	89.58	89.7	0.7	
	Solid Std	N/A		2580.11	2579.73	2580.10	2580.0		
	Filter Blank	67.2		10.77	11.40	10.64	10.9	0.2	
	Solution Blank	N/A		9.93	9.12	9.22	9.4		
Second Wash	Filter	61.4		54.52	54.44	54.42	54.5	0.9	
	Fittings	53.2		86.43	87.16	87.18	86.9	1.6	0.9821
	Diluter	114.2		17.18	17.44	17.51	17.4	0.2	
	Solid Std	N/A		2591.89	2592.11	2592.18	2592.1		
	Filter Blank	62.3		9.84	9.62	9.82	9.8	0.2	
	Solution Blank	N/A		9.45	9.43	9.42	9.4		
Third Wash	Filter	64.5		30.47	30.17	30.26	30.3	0.5	
	Fittings	52.6		29.26	29.12	29.34	29.2	0.6	0.9801
	Diluter	117.9		14.68	14.69	14.70	14.7	0.1	
	Solid Std	N/A		2590.45	2590.55	2590.75	2590.6		
	Filter Blank	64.8		8.43	8.47	8.97	8.6	0.1	
	Solution Blank	N/A		9.77	9.84	9.91	9.8		
Notes: Include a filter efficiency check with this test.									
Pre-test wash, Fittings #2. 52.7g: 37.88, 38.02, 37.91 RFU									
First wash, Filter #2. 61.5g: 14.02, 14.05, 13.78 RFU									
Fittings #2. 60.6g: 17.61, 17.73, 17.84 RFU									
Used AutoVial for everything on the 1st wash, then only the filters for 2nd & 3rd washes.									
/ JEF 11/5/13									
Entries made by:	Julia Flaherty			Technical Data Review performed by:			Carmen Arimescu		
Signature/date	On File w/ Original 11/5/2013			Signature/date			On File w/ Original 3/13/2014		

HIGH TEMPERATURE PROBE TESTING - Aerosol Penetration						
Aerosol and Dilution Data						
Run No.	AP-15		Facility	HV-S3		
Date	11/22/2013		Chamber Set Point	HV-S3 Min, 261°F / 2.3%RH		
Start/End Time	10:30 / 11:10		Diluter Flows	Min stack, Max ISA		
Testers	JEF		Diluter Orientation	Mostly Vert		
	Start	Finish	Materials and Equipment Used:			Cal Due
Time	10:30	11:10	Thermotron SE-2000-4 Env Chamber S/N 42857			4/2/2014
Chamber Temp	261	261	°F	Alicat MCR-500SLPM MFC	SN 68858	2/4/2014
Chamber Humidity	2.3%	2.3%	RH	Alicat MCR-500SLPM-D MFC	SN 68857	4/3/2014
Dilution flowcontroller	3.61	3.61	scfm	Vaisala MI70/HMP77B	S/N G5230040/H0320001	1/31/2014
Dilution Dew Pt	-26	-25	°F	Vaisala MI70/DMP74B	S/N G5230040/H0320001	1/31/2014
Dilution Temp	68.3	67.5	°F	Type T Thermocouples	T004 - T006, T008, T009	6/18/2014
Dilution P	15.2	15.2	psia	Mott Corp Diluter 32" OAL	Model 7610S-1.375-24-2-AB	N/A
Sampling flowcontroller	4.53	4.53	scfm	Fisher Dew Point Pen	S/N 122277883	5/16/2014
Sampling Dew Pt	57	57	°F	TSI VOAG, Model 345001	S/N 406	N/A
Sampling Temp	99	99	°F	VOAG Aerosol Solution (filtered) ID AS08	made on 11/19/13	
Sampling P	14.5	14.4	psia	Hach OPC	S/N 1011529010	3/7/2014
Ambient pressure	1029	1028	mbar	TSI APS, Model 3321	S/N 70907086	7/29/2014
Ambient humidity	14.3%	16.3%	RH			
Ambient Temp	72.6	72.6	°F	Droplet Diameter: $Dd = (6Q/\pi f)^{1/3}$		47.5 μm
VOAG Frequency	42.06	41.65	kHz			
VOAG Syringe Speed	4.2	4.2	$\times 10^{-4}$ cm/s		Aerosol concentration, C	0.168
VOAG Dispersion Air	10	10	cc/min x 100		Aerosol density, ρ	0.893
VOAG Dilution Air	60	60	LPM			
APS Mean AD	14.5	10.40	μm	Particle Diameter: $Dp = (C+I)^{1/3}Dd$		26.2 μm
APS Sig-G	1.533	1.750		Aerodynamic Diameter: $AD = Dp \cdot \text{SQRT}(\rho)/1$		24.8 μm
Notes: Heat tape on at 8:36, set up to 230°F (omega).						
Sample flow on at 8:46. Compressed air P ~70psi.						
9:13 replaced upper desiccant. Td ~-13°F.						
Aerosol jet stopped at 10:36. Re-started by 10:37. Occasionally, the particle size distribution looked terrible.						
The peak was still between 10 & 15 μm , but some particles with smaller AD were also measured.						
Can't do much about it, so run the test for a few extra minutes to reduce the contribution of the spurious particles to the final result. Smaller diameter is much smaller volume.						
11:05 changed VOAG frequency to 41.65 kHz to more closely match yesterday's test, and maybe eliminate noisy particles.						
Not much change.						
/						
JEF 11/22/13						
Data Files						
Environmental Chamber Data: 131122_hvs3_min.csv						
FIO Vaisala Dew Point Data: 2013-11-22 10_12.csv						
FIO Alicat Data: 20131122_0942_alicat.dat						
FIO APS Data: test_nov_22_2013_1.A21						
Entries made by:	Julia Flaherty			Technical Data Review performed by: Carmen Arimescu		
Signature/date	On File w/ Original 11/22/2013			On File w/ Original 3/13/2014		

HIGH TEMPERATURE PROBE TESTING - Aerosol Penetration									
Fluorometry Data									
Run No.	AP-15			Facility	HV-S3				
Date	11/21 - 11/22/13			Chamber Set Point	261°F / 2.3% RH				
Start/End Time	4:30 - 12:45			Diluter Flows	Min Stack, Max ISA				
Testers	JEF			Diluter Orientation	Mostly Vert				
Materials and Equipment Used:				Cal Due					
Turner Trilogy Fluorometer			S/N 720000895	N/A					
Sartorius QS 2000 Lab Balance			S/N 60502077	6/24/2014					
N/A									
Aerosol Wash Solution			ID AW13	Made on 11/1/2013					
Whatman AutoVial (PTFE filter media)			N/A						
N/A									
	Wash Solution			Fluorescence				RFU/g	Aerosol Penetration
	Sample	Mass (g)		1 - RFU	2 - RFU	3 - RFU	Mean		
Pre-Test Wash	Fittings	54.3		11304.83	11299.10	11305.69	11303.2	208.2	N/A
	Diluter	117.2		486.84	484.97	487.06	486.3	4.1	
	Solid Std	N/A		2558.67	2557.74	2557.41	2557.9		
	Solution Blank	N/A		8.90	8.95	8.87	8.9		
First Wash	Filter	64.4		358.37	359.70	360.34	359.5	5.6	0.9623
	Fittings	60.0		801.09	802.11	800.22	801.1	13.4	
	Diluter	121.3		89.79	90.10	89.98	90.0	0.7	
	Solid Std	N/A		2581.39	2581.14	2581.00	2581.2		
	Filter Blank	64.2		12.89	12.92	13.07	13.0	0.2	
	Solution Blank	N/A		8.95	8.95	9.10	9.0		
Second Wash	Filter	61.3		66.66	66.14	66.07	66.3	1.1	0.9592
	Fittings	47.1		58.52	58.60	58.59	58.6	1.2	
	Diluter	117.1		18.60	19.15	19.30	19.0	0.2	
	Solid Std	N/A		2583.64	2853.33	2583.19	2673.4		
	Filter Blank	60.0		11.31	11.31	11.16	11.3	0.2	
	Solution Blank	N/A		9.90	9.79	9.79	9.8		
Third Wash	Filter	62.2		29.00	29.15	29.51	29.2	0.5	0.9546
	Fittings	51.1		28.88	28.70	28.80	28.8	0.6	
	Diluter	115.6		16.67	18.64	18.91	18.1	0.2	
	Solid Std	N/A		2590.79	2590.89	2590.81	2590.8		
	Filter Blank	60.8		8.72	8.81	8.99	8.8	0.1	
	Solution Blank	N/A		10.24	10.27	10.58	10.4		
Notes: Pre-Test set up had the splitter. Ran tests on 11/12 & 11/21 with larger aerosol. Add extra pre-test wash components.									
Splitter : 28.3 g 146194.85, 144587.37, 137652.10 RFU (too much wash)									
Fittings #2 : 42.7 g 3248.69, 3239.88, 3250.05 RFU									
Filter : 71.0 g 353.14, 351.49, 351.35 RFU									
Wipe out the fittings for the test. Wash again.									
Fittings : 52.3 g 47.25, 48.97, 48.55 RFU									
Diluter : 98.0 g 20.73, 20.71, 21.02 RFU									
Use AutoVial for first wash, then only filters on 2nd and 3rd washes.									
N/A									
Entries made by:	Julia Flaherty			Technical Data Review performed by:			Carmen Arimescu		
Signature/date	On File w/ Original 11/22/2013			Signature/date			On File w/ Original 3/13/2014		

HIGH TEMPERATURE PROBE TESTING - Aerosol Penetration						
Aerosol and Dilution Data						
Run No.	AP-16		Facility	HV-S3		
Date	1/16/2014		Chamber Set Point	261°F / 2.3%RH		
Start/End Time	11:31 / 12:20 *		Diluter Flows	Min stack, Max ISA		
Testers	JEF		Diluter Orientation	Mostly Vert (20° from Vert)		
	Start	Finish	Materials and Equipment Used:			Cal Due
Time	11:31	12:20	Thermotron SE-2000-4 Env Chamber S/N 42857			4/2/2014
Chamber Temp	261	261	°F	Alicat MCR-500SLPM MFC	SN 68858	2/4/2014
Chamber Humidity	2.3%	2.3%	RH	Alicat MCR-500SLPM-D MFC	SN 68857	4/3/2014
Dilution flowcontroller	3.61	3.61	scfm	Vaisala MI70/HMP77B	S/N G5230040/H0320001	1/31/2014
Dilution Dew Pt	-25.7	-23.7	°F	Vaisala MI70/DMP74B	S/N G5230040/H0320001	1/31/2014
Dilution Temp	73.5	72.3	°F	Type T Thermocouples	T004 - T006, T008, T009	6/18/2014
Dilution P	15.0	15.0	psia	Mott Corp Diluter 32" OAL	Model 7610S-1.375-24-2-AB	N/A
Sampling flowcontroller	4.53	4.53	scfm	Fisher Dew Point Pen	S/N 122277883	5/16/2014
Sampling Dew Pt	57	57	°F	TSI VOAG, Model 345001	S/N 406	N/A
Sampling Temp	105	105	°F	VOAG Aerosol Solution (filtered)	ID AS09	made on 1/8/14
Sampling P	14.3	14.3	psia	Hach OPC	S/N 1011529010	3/7/2014
Ambient pressure	1020	1020	mbar	TSI APS, Model 3321	S/N 70907086	7/29/2014
Ambient humidity	20.4%	21.1%	RH			
Ambient Temp	77.5	77.3	°F	Droplet Diameter: $Dd = (6Q/\pi f)^{1/3}$		43.7 μm
VOAG Frequency	55.16	53.39	kHz			
VOAG Syringe Speed	4.2	4.2	$\times 10^{-4}$ cm/s		Aerosol concentration, C	0.1677
VOAG Dispersion Air	10	10	cc/min x 100		Aerosol density, ρ	0.8931
VOAG Dilution Air	60	60	LPM			
APS Mean AD	14.0	13.2	μm	Particle Diameter: $Dp = (C+I)^{1/3}Dd$		24.1 μm
APS Sig-G	1.603	1.322		Aerodynamic Diameter: $AD = Dp \cdot \text{SQRT}(\rho)/1$		22.8 μm
Notes: Set heat tape to 230°F on Omega at ~10:09.						
Chamber at 258°F / 0.8%RH (60°F dp).						
Start mass flow controllers at ~10:16.						
10:52 chamber is pretty close to final SP, running IPA on VOAG, ISA ~-20°F dp, conditioned air is ~103°F. Plan on switching to AS09 at ~11:00.						
APS distribution was clean before connecting VOAG to chamber. Afterwards, shows lots of noisy counts evenly distributed over all bins during most times. 11:37 looks ok - 4 bins, btwn 12 & 15 μm . (Sample #27)						
Artifact of measurement through tee? Disconnect VOAG from chamber 11:50 - 12:05, troubleshoot, back online w/ mean = 13.2 μm , Peak = 16 μm .						
*Took a 15 min VOAG troubleshooting break, so the aerosol injection duration was 34 min.						
/						
JEF 1/16/14						
Data Files						
Environmental Chamber Data:		140116_hvs3_min.csv				
FIO Vaisala Dew Point Data:		2014-01-16 11_45.csv				
FIO Alicat Data:		20140116_1113_alicat.dat				
FIO APS Data:		test_jan_16_2014_1.A21				
Entries made by:	Julia Flaherty		Technical Data Review performed by:		Carmen Arimescu	
Signature/date	On File w/ Original 1/16/2014		Signature/date		On File w/ Original 3/13/2014	

HIGH TEMPERATURE PROBE TESTING - Aerosol Penetration									
Fluorometry Data									
Run No.	AP-16			Facility	HV-S3				
Date	1/16/2014			Chamber Set Point	261°F / 2.3%RH				
Start/End Time	9:15 / 14:10			Diluter Flows	Min Stack, Max ISA				
Testers	JEF			Diluter Orientation	Mostly Vert (20° from vert)				
Materials and Equipment Used:				Cal Due					
Turner Trilogy Fluorometer		S/N 720000895						N/A	
Sartorius QS 2000 Lab Balance		S/N 60502077						6/24/2014	
N/A									
Aerosol Wash Solution		ID AW14						Made on 1/15/14	
Whatman AutoVial (PTFE filter media)								N/A	
N/A								N/A	
Wash Solution			Fluorescence				Aerosol		
	Sample	Mass (g)		1 - RFU	2 - RFU	3 - RFU	Mean	RFU/g	Penetration
Pre-Test Wash	Fittings	66.9		21.01	21.85	21.82	21.6	0.3	N/A
	Diluter	129.9		23.81	23.71	23.85	23.8	0.2	
	Solid Std	N/A		2574.67	2574.96	2575.51	2575.0		
	Solution Blank	N/A		21.56	21.70	21.32	21.5		
First Wash	Filter	64.1		503.11	502.98	501.77	502.6	7.8	0.9672
	Fittings	62.6		565.46	562.87	563.37	563.9	9.0	
	Diluter	123.1		70.43	70.32	70.52	70.4	0.6	
	Solid Std	N/A		2570.57	2569.68	2569.56	2569.9		
	Filter Blank	60.5		13.06	12.94	12.94	13.0	0.2	
	Solution Blank	N/A		20.49	20.52	20.61	20.5		
Second Wash	Filter	55.5		105.48	105.45	105.70	105.5	1.9	0.9648
	Fittings	68.0		48.09	47.93	48.11	48.0	0.7	
	Diluter	120.1		15.80	16.02	17.87	16.6	0.1	
	Solid Std	N/A		2589.60	2589.59	2588.35	2589.2		
	Filter Blank	57.0		208.27	209.14	207.90	208.4	3.7	
	Solution Blank	N/A		21.19	21.25	21.28	21.2		
Third Wash	Filter	66.5		38.75	30.41	30.00	33.1	0.5	0.9563
	Fittings	67.2		21.60	21.64	21.64	21.6	0.3	
	Diluter	111.2		23.94	23.78	24.78	24.2	0.2	
	Solid Std	N/A		2575.23	2575.98	2575.67	2575.6		
	Filter Blank	64.2		29.84	38.77	39.33	36.0	0.6	
	Solution Blank	N/A		21.40	21.42	21.64	21.5		
Notes: Used Whatman AutoVial for everything on 1st wash, then only filters for 2nd and 3rd washes.									
Re-run "filter blank" from 2nd wash (w/o AutoVial)									
223.76, 223.91, 223.51 RFU. Must've switched filters? But still doesn't make sense. Except... if it's reversed, then there could be									
cross-contamination w/ forceps used to handle filters. 105 RFU is still an awfully high value.									
Thought the filters were switched, but the 3rd wash seems to indicate it was not... pretty strange.									
/									
JEF 1/16/14									
Entries made by:		Julia Flaherty			Technical Data Review performed by:		Carmen Arimescu		
Signature/date		On File w/ Original		1/16/2014		Signature/date		On File w/ Original 3/13/2014	

HIGH TEMPERATURE PROBE TESTING - Aerosol Penetration			
VOAG Aerosol Solution Data			
Date	8/8/2013	Facility	HV-S3
Time	4:30	Testers	JEF, MSP
ID	AS02		
Materials and Equipment Used:		Cal Due	
Sartorius QS 2000 Lab Balance	S/N 60502077	6/24/2014	
Sartorius CPA 224A Lab Balance	S/N 27950023	9/29/2013	
3 mL disposable pipettes			
Turner Designs Fluorescein	Lot # A216E236	N/A	
Isopropyl Alcohol, 99.9%			
Oleic Acid, Technical Grade, 90%	Lot # MKBK4194V	N/A	
Target Mix, by volume:		Density, g/mL	
Oleic Acid	1.0	0.89	
Fluorescein Solution	0.02	1.28	
Isopropyl Alcohol	65	0.79	
Target Mix, by mass:		mass in 400 g	
Oleic Acid	0.89	6.8114	
Fluorescein Solution	0.0256	0.1959	
Isopropyl Alcohol	51.35	392.9927	
<i>Total:</i>	<i>52.2656</i>	<i>400.0000</i>	
Actual Mix, by mass:		by volume	in 66.02 parts
Oleic Acid	6.8095	7.65	1.00
Fluorescein Solution	0.1936	0.15	0.02
Isopropyl Alcohol	392.9	497.34	65.00
<i>Total:</i>	<i>399.9031</i>	<i>505.14</i>	<i>66.02</i>
Volumetric Concentration of nonvolatile solute, C		0.0153	
Aerosol Density, ρ		0.8931	
Notes: TSI APS: Mean AD = 8.6 microns, and peak (AKA mode) AD = 8.35 micron.			
/ JEF 8/8/13			
Entries made by:	Julia Flaherty	Technical Data Review performed by: Carmen Arimescu	
Signature/date	On File w/ Orig 8/8/2013	Signature/date On File w/ Original 3/13/2014	

HIGH TEMPERATURE PROBE TESTING - Aerosol Penetration			
VOAG Aerosol Solution Data			
Date	9/19/2013	Facility	HV-S3
Time	4:10	Testers	JEF, MSP
ID	AS03		
Materials and Equipment Used:			Cal Due
Sartorius QS 2000 Lab Balance	S/N 60502077		6/24/2014
Sartorius CPA 224A Lab Balance	S/N 27950023		9/29/2013
3 mL disposable pipettes			
Turner Designs Fluorescein	Lot # A216E236		N/A
Isopropyl Alcohol, 99.9%			N/A
Oleic Acid, Technical Grade, 90%	Lot # MKBK4194V		N/A
Target Mix, by volume:		Density, g/mL	
Oleic Acid	1.0		0.89
Fluorescein Solution	0.02		1.28
Isopropyl Alcohol	60		0.79
Target Mix, by mass:		mass in 200 g	
Oleic Acid	0.89		3.6841
Fluorescein Solution	0.0256		0.1060
Isopropyl Alcohol	47.4		196.2099
<i>Total:</i>	<i>48.3156</i>		<i>200.0000</i>
Actual Mix, by mass:		by volume	in 61.02 parts
Oleic Acid	3.6823	4.14	1.00
Fluorescein Solution	0.1073	0.08	0.02
Isopropyl Alcohol	196.2	248.35	60.00
<i>Total:</i>	<i>199.9896</i>	<i>252.58</i>	<i>61.02</i>
Volumetric Concentration of nonvolatile solute, C		0.0165	
Aerosol Density, ρ		0.8931	
Notes:			
/			
Entries made by: Julia Flaherty		Technical Data Review performed by: Carmen Arimescu	
Signature/date: On File w/ Original 9/19/2013		Signature/date: On File w/ Original 3/13/2014	

HIGH TEMPERATURE PROBE TESTING - Aerosol Penetration			
VOAG Aerosol Solution Data			
Date	9/26/2013	Facility	HV-S3
Time	10:00	Testers	JEF, MSP
ID	AS04		
Materials and Equipment Used:			Cal Due
Sartorius QS 2000 Lab Balance	S/N 60502077		6/24/2014
Sartorius CPA 224A Lab Balance	S/N 27950023		9/29/2013
3 mL disposable pipettes			
Turner Designs Fluorescein	Lot # A216E236		N/A
Isopropyl Alcohol, 99.9%			N/A
Oleic Acid, Technical Grade, 90%	Lot # MKBK4194V		N/A
Target Mix, by volume:		Density, g/mL	
Oleic Acid	1.0		0.89
Fluorescein Solution	0.02		1.28
Isopropyl Alcohol	30		0.79
Target Mix, by mass:		mass in 200 g	
Oleic Acid	0.89		7.2312
Fluorescein Solution	0.0256		0.2080
Isopropyl Alcohol	23.7		192.5608
<i>Total:</i>	<i>24.6156</i>		<i>200.0000</i>
Actual Mix, by mass:		by volume	in 31.02 parts
Oleic Acid	7.2112	8.10	1.00
Fluorescein Solution	0.1911	0.15	0.02
Isopropyl Alcohol	193.0	244.30	30.01
<i>Total:</i>	<i>200.4023</i>	<i>252.56</i>	<i>31.02</i>
Volumetric Concentration of nonvolatile solute, C		0.0323	
Aerosol Density, ρ		0.8929	
Notes: 250 mL amber bottle: 164.4184g			
/ JF 9/26/13			
Entries made by: Julia Flaherty		Technical Data Review performed by: Carmen Arimescu	
Signature/date: On File w/ Original 9/26/2013		Signature/date: On File w/ Original 3/13/2014	

HIGH TEMPERATURE PROBE TESTING - Aerosol Penetration			
VOAG Aerosol Solution Data			
Date	11/1/2013	Facility	HV-S3
Time	8:55 - 9:20	Testers	JEF
ID	AS05		
Materials and Equipment Used:		Cal Due	
Sartorius QS 2000 Lab Balance	S/N 60502077	6/24/2014	
Sartorius CPA 224A Lab Balance	S/N 27950023	9/29/2013	
3 mL disposable pipettes			
Turner Designs Fluorescein	Lot # A216E236	N/A	
Isopropyl Alcohol, 99.9%	Lot 132647	N/A (CMS 393153)	
Oleic Acid, Technical Grade, 90%	Lot # MKBK4194V	N/A (CMS 392805)	
Oleic Acid, Technical Grade, 90%	Lot # MKBH5625V	N/A	
Isopropyl Alcohol	Lot 127641	N/A (CMS 393154)	
Target Mix, by volume:		Density, g/mL	
Oleic Acid	1.0	0.89	
Fluorescein Solution	0.02	1.28	
Isopropyl Alcohol	30	0.79	
Target Mix, by mass:		mass in 200 g	
Oleic Acid	0.89	7.2312	
Fluorescein Solution	0.0256	0.2080	
Isopropyl Alcohol	23.7	192.5608	
<i>Total:</i>	<i>24.6156</i>	<i>200.0000</i>	
Actual Mix, by mass:		by volume in 31.02 parts	
Oleic Acid	7.2364	8.13	1.00
Fluorescein Solution	0.201	0.16	0.02
Isopropyl Alcohol	192.5	243.67	30.00
<i>Total:</i>	<i>199.9374</i>	<i>251.96</i>	<i>31.02</i>
Volumetric Concentration of nonvolatile solute, C		0.0325	
Aerosol Density, ρ		0.8930	
Notes: 250 mL amber bottle = 164.9953 g.			
Oleic: 5.3476 g from CMS# 392805 (Lot#MKBK4194V). Balance from Lot# MKBH5625V. Bottle contains material floating inside - looks like glass fibers or polyester batting... Shake, but stays.			
Emptied IPA CMS # 393153.			
Entries made by:	Julia Flaherty	Technical Data Review performed by:	Carmen Arimescu
Signature/date	On File w/ Original 11/1/2013	Signature/date	On File w/ Original 3/13/2014

HIGH TEMPERATURE PROBE TESTING - Aerosol Penetration			
VOAG Aerosol Solution Data			
Date	11/15/2013	Facility	HV-S3
Time	8:05 - 8:20	Testers	JEF
ID	AS06		
Materials and Equipment Used:			Cal Due
Sartorius QS 2000 Lab Balance	S/N 60502077		6/24/2014
Sartorius CPA 224A Lab Balance	S/N 27950023		9/29/2013
3 mL disposable pipettes			
Turner Designs Fluorescein	Lot # A216E236		N/A
Isopropyl Alcohol, 99.9%	Lot #127641		N/A (CMS 393154)
Oleic Acid, Technical Grade, 90%	Lot # MKBH5625V		N/A
/			
JEF 11/15/13			
Target Mix, by volume:		Density, g/mL	
Oleic Acid	1.0		0.89
Fluorescein Solution	0.02		1.28
Isopropyl Alcohol	20		0.79
Target Mix, by mass:		mass in 80 g	
Oleic Acid	0.89		4.2595
Fluorescein Solution	0.0256		0.1225
Isopropyl Alcohol	15.8		75.6180
<i>Total:</i>	<i>16.7156</i>		<i>80.0000</i>
Actual Mix, by mass:		by volume	in 21.02 parts
Oleic Acid	4.2603	4.79	1.00
Fluorescein Solution	0.1495	0.12	0.02
Isopropyl Alcohol	75.6	95.70	20.00
<i>Total:</i>	<i>80.0098</i>	<i>100.60</i>	<i>21.02</i>
Volumetric Concentration of nonvolatile solute, C		0.0481	
Aerosol Density, ρ		0.8938	
Notes: Use 120mL amber bottle. Oleic acid is pretty cloudy - still has lots of material that looks like polyester batting...			
/			
JEF 11/15/13			
Entries made by:	Julia Flaherty	Technical Data Review performed by:	Carmen Arimescu
Signature/date	On File w/ Original 11/15/2013	Signature/date	On File w/ Original 3/13/2014

HIGH TEMPERATURE PROBE TESTING - Aerosol Penetration			
VOAG Aerosol Solution Data			
Date	11/15/2013	Facility	HV-S3
Time	8:30 - 8:45	Testers	JEF
ID	AS07		
Materials and Equipment Used:		Cal Due	
Sartorius QS 2000 Lab Balance	S/N 60502077	6/24/2014	
Sartorius CPA 224A Lab Balance	S/N 27950023	9/29/2013	
3 mL disposable pipettes			
Turner Designs Fluorescein	Lot # A216E236	N/A	
Isopropyl Alcohol, 99.9%	Lot #127641	N/A (CMS 393154)	
Oleic Acid, Technical Grade, 90%	Lot # MKBH5625V	N/A	
/			
JEF 11/15/13			
Target Mix, by volume:		Density, g/mL	
Oleic Acid	1.0	0.89	
Fluorescein Solution	0.02	1.28	
Isopropyl Alcohol	15	0.79	
Target Mix, by mass:		mass in 80 g	
Oleic Acid	0.89	5.5775	
Fluorescein Solution	0.0256	0.1604	
Isopropyl Alcohol	11.85	74.2621	
<i>Total:</i>	<i>12.7656</i>	<i>80.0000</i>	
Actual Mix, by mass:		by volume in 16.02 parts	
Oleic Acid	5.5765	6.27	1.00
Fluorescein Solution	0.1638	0.13	0.02
Isopropyl Alcohol	74.3	94.05	15.00
<i>Total:</i>	<i>80.0403</i>	<i>100.44</i>	<i>16.02</i>
Volumetric Concentration of nonvolatile solute, C		0.0629	
Aerosol Density, ρ		0.8932	
Notes: Use 120mL amber bottle. Oleic acid is pretty cloudy - still has lots of material that looks like polyester batting...			
/			
JEF 11/15/13			
Entries made by:	Julia Flaherty	Technical Data Review performed by:	Carmen Arimescu
Signature/date	On File w/ Original 11/15/2013	Signature/date	On File w/ Original 3/13/2014

HIGH TEMPERATURE PROBE TESTING - Aerosol Penetration			
VOAG Aerosol Solution Data			
Date	11/19/2013	Facility	HV-S3
Time	5:20 / 5:40	Testers	JEF
ID	AS08		
Materials and Equipment Used:		Cal Due	
Sartorius QS 2000 Lab Balance	S/N 60502077	6/24/2014	
Sartorius CPA 224A Lab Balance	S/N 27950023	9/29/2013	
3 mL disposable pipettes			
Turner Designs Fluorescein	Lot # A216E236	N/A	
Isopropyl Alcohol, 99.9%	Lot #127641	N/A (CMS 393154)	
Oleic Acid, Technical Grade, 90%	Lot # MKBH5625V	N/A	
/			
JEF 11/19/13			
Target Mix, by volume:		Density, g/mL	
Oleic Acid	1.0	0.89	
Fluorescein Solution	0.02	1.28	
Isopropyl Alcohol	5	0.79	
Target Mix, by mass:		mass in 90 g	
Oleic Acid	0.89	16.4625	
Fluorescein Solution	0.0256	0.4735	
Isopropyl Alcohol	3.95	73.0640	
<i>Total:</i>	<i>4.8656</i>	<i>90.0000</i>	
Actual Mix, by mass:		by volume in 6.02 parts	
Oleic Acid	16.4774	18.51	1.00
Fluorescein Solution	0.4635	0.36	0.02
Isopropyl Alcohol	73.0	92.41	5.00
<i>Total:</i>	<i>89.9409</i>	<i>111.28</i>	<i>6.02</i>
Volumetric Concentration of nonvolatile solute, C		0.1680	
Aerosol Density, ρ		0.8930	
Notes: Amber bottle - 162.9815 g (250 mL).			
Lots of cloudy, fibrous material in the oleic acid - looks like polyester batting.			
/			
JEF 11/19/2013			
Entries made by:	Julia Flaherty	Technical Data Review performed by:	Carmen Arimescu
Signature/date	On File w/ Original 11/19/2013	Signature/date	On File w/ Original 3/13/2014

HIGH TEMPERATURE PROBE TESTING - Aerosol Penetration			
VOAG Aerosol Solution Data			
Date	1/8/2014	Facility	HV-S3
Time	11:00	Testers	JEF
ID	AS09		
Materials and Equipment Used:		Cal Due	
Sartorius QS 2000 Lab Balance	S/N 60502077	6/24/2014	
N/A			
3 mL disposable pipettes			
Turner Designs Fluorescein	Lot # A216E236	N/A	
Isopropyl Alcohol, 99.9%	Lot #132647	N/A (CMS#393155)	
Oleic Acid, Technical Grade, 90%	Lot # MKBH5625V	N/A	
/			
JEF 1/8/14			
Target Mix, by volume:		Density, g/mL	
Oleic Acid	1.0	0.89	
Fluorescein Solution	0.02	1.28	
Isopropyl Alcohol	5	0.79	
Target Mix, by mass:		mass in 250 g	
Oleic Acid	0.89	45.7292	
Fluorescein Solution	0.0256	1.3154	
Isopropyl Alcohol	3.95	202.9554	
<i>Total:</i>	<i>4.8656</i>	<i>250.0000</i>	
Actual Mix, by mass:		by volume in 6.02 parts	
Oleic Acid	45.7	51.35	1.00
Fluorescein Solution	1.3	1.02	0.02
Isopropyl Alcohol	202.9	256.84	5.00
<i>Total:</i>	<i>249.9</i>	<i>309.20</i>	<i>6.02</i>
Volumetric Concentration of nonvolatile solute, C		0.1677	
Aerosol Density, ρ		0.8931	
Notes: Same ratio as AS08. Larger volume to accommodate use of QS2000 lab balance.			
Lots of cloudy, fibrous material in the oleic acid - looks like polyester batting.			
/			
JEF 1/8/2014			
Entries made by:	Julia Flaherty	Technical Data Review performed by:	Carmen Arimescu
Signature/date	On File w/ Original 1/8/2014	Signature/date	On File w/ Original 3/13/2014

HIGH TEMPERATURE PROBE TESTING - Aerosol Penetration

Aerosol Wash Solution Data

Date **9/10/2013**

Facility **HV-S3**

Time **12:25 - 12:50**

Tester(s) **JEF**

ID **AW07**

Materials and Equipment Used:

Cal Due

Sartorius QS 2000 Lab Balance S/N 60502077 6/24/2014

N/A

VWR 2000 mL graduated cylinder, B, Tol +/- 10.0 N/A

3 mL disposable pipettes N/A

Whatman pH indicator paper, Type CF (Cat. No. 2614991) N/A

Wash Solution AW06 Made on 7/9/13

2-propanol, Fisher Lot 127641 N/A (CMS 393150)

2-propanol, Fisher Lot 132647 N/A (CMS 393149)

	Volume (mL)	Mass (g)
Deionized water	1400	1385.0
Isopropyl alcohol	1400	1083.2

of NH4OH drops: 15

pH: 8.5 Target pH = 8.0-10.0

Notes: Graduated cylinder weighs 1122.1 g empty.

CMS 393150 empty.

JF 9/10/13

Entries made by: Julia Flaherty	Technical Data Review performed by: Carmen Arimescu
Signature/date On File w/ Orig 9/10/2013	Signature/date On File w/ Original 3/13/2014

HIGH TEMPERATURE PROBE TESTING - Aerosol Penetration

Aerosol Wash Solution Data

Date	9/12/2013	Facility	HV-S3
Time	6:30 - 6:55	Tester(s)	JEF
ID	AW08		

Materials and Equipment Used:		Cal Due
Sartorius QS 2000 Lab Balance	S/N 60502077	6/24/2014
VWR 2000 mL graduated cylinder, B, Tol +/- 10.0		N/A
3 mL disposable pipettes		N/A
Whatman pH indicator paper, Type CF (Cat. No. 2614991)		N/A
Wash Solution	AW07	Made on 9/10/13
Fisher Scientific 2-propanol	Lot 132647	N/A (CMS 393149)
Fisher Scientific 2-propanol	Lot 127641	N/A (CMS 393151)
Fisher Scientific 2-propanol	Lot 132647	N/A (CMS 393152)

	Volume (mL)	Mass (g)	
Deionized water	1400	1385.2	
Isopropyl alcohol	1400	1084.5	
# of NH4OH drops:	16		
pH:	8.0		Target pH = 8.0-10.0

Notes: Emptied CMS # 393149 and 393151.

/

JF 9/12/13

Entries made by:	Julia Flaherty	Technical Data Review performed by:	Carmen Arimescu
Signature/date	<i>On File w/ Orig</i> 9/12/2013	Signature/date	<i>On File w/ Original</i> 3/13/2014

HIGH TEMPERATURE PROBE TESTING - Aerosol Penetration

Aerosol Wash Solution Data

Date **9/17/2013**

Facility **HV-S3**

Time **12:10 - 12:35**

Tester(s) **JEF**

ID **AW09**

Materials and Equipment Used:

Cal Due

Sartorius QS 2000 Lab Balance	S/N 60502077	6/24/2014
VWR 2000 mL graduated cylinder, B, Tol +/- 10.0		N/A
3 mL disposable pipettes		N/A
Whatman pH indicator paper, Type CF (Cat. No. 2614991)		N/A
Wash Solution	AW08	Made on 9/12/13
Fisher Scientific 2-propanol	Lot 132647	N/A (CMS 393152)
Fisher Scientific 2-propanol	Lot 127641	N/A (CMS 392784)
Fisher Scientific 2-propanol	Lot 127641	N/A (CMS 392785)

	Volume (mL)	Mass (g)
Deionized water	1700	1684.0
Isopropyl alcohol	1700	1324.0

of NH4OH drops: **20**

pH: **8.0** Target pH = 8.0-10.0

Notes: Less than 0.5L of AW08 left.

Starting pH ~7.0.

CMS 393152 and 392784 are empty.

JF 9/17/13

Entries made by: Julia Flaherty	Technical Data Review performed by: Carmen Arimescu
Signature/date On File w/ Orig 9/17/2013	Signature/date On File w/ Original 3/13/2014

HIGH TEMPERATURE PROBE TESTING - Aerosol Penetration

Aerosol Wash Solution Data

Date **9/20/2013**

Facility **HV-S3**

Time **14:10 - 14:50**

Tester(s) **JEF**

ID **AW10**

Materials and Equipment Used:

Cal Due

Sartorius QS 2000 Lab Balance	S/N 60502077	6/24/2014
VWR 2000 mL graduated cylinder, B, Tol +/- 10.0		N/A
3 mL disposable pipettes		N/A
Whatman pH indicator paper, Type CF (Cat. No. 2614991)		N/A
Wash Solution	AW09	Made on 9/17/13
Fisher Scientific 2-propanol	Lot 127641	N/A (CMS 392785)
Fisher Scientific 2-propanol	Lot 127641	N/A (CMS 392786)
Fisher Scientific 2-propanol	Lot 132647	N/A (CMS 393144)

	Volume (mL)	Mass (g)
Deionized water	1600	1585.6
Isopropyl alcohol	1600	1245.9

of NH4OH drops: **20**

pH: **8.0** Target pH = 8.0-10.0

Notes: About 750 mL of AW09 is left.
Emptied CMS 392785 and 392786.

JF 9/20/13

Entries made by: Julia Flaherty	Carmen Arimescu
Signature/date <i>On File w/ Orig</i> 9/20/2013	Signature/date <i>On File w/ Original</i> 3/13/2014

HIGH TEMPERATURE PROBE TESTING - Aerosol Penetration

Aerosol Wash Solution Data

Date **9/30/2013**

Facility **HV-S3**

Time **8:30 - 8:45**

Tester(s) **JEF**

ID **AW11**

Materials and Equipment Used:

Cal Due

Sartorius QS 2000 Lab Balance	S/N 60502077	6/24/2014
VWR 2000 mL graduated cylinder, B, Tol +/- 10.0		N/A
3 mL disposable pipettes		N/A
Whatman pH indicator paper, Type CF (Cat. No. 2614991)		N/A
Wash Solution	AW10	Made on 9/20/13
Fisher Scientific 2-propanol	Lot 132647	N/A (CMS 393146)
Fisher Scientific 2-propanol	Lot 132647	N/A (CMS 393148)
N/A		

	Volume (mL)	Mass (g)
Deionized water	1400	1388.3
Isopropyl alcohol	1400	1089.3

of NH4OH drops: **20**

pH: **8.0** Target pH = 8.0-10.0

Notes: About 1 L of AW10 is left.
 Emptied CMS 393146.
 Before NH4OH, the pH of the mixture was right around 7.
 After adding NH4OH, the pH was between 8.0 and 8.5, but closer in color to 8.0.

9/30/2013

Entries made by: Julia Flaherty	Technical Data Review performed by: Carmen Arimescu
Signature/date <i>On File w/ Orig</i> 9/30/2013	Signature/date <i>On File w/ Original</i> 3/13/2014

HIGH TEMPERATURE PROBE TESTING - Aerosol Penetration

Aerosol Wash Solution Data

Date **10/21/2013**

Facility **HV-S3**

Time **11:55 - 12:15**

Tester(s) **JEF**

ID **AW12**

Materials and Equipment Used:

Cal Due

Sartorius QS 2000 Lab Balance S/N 60502077 6/24/2014

WWR 2000 mL graduated cylinder, B, Tol +/- 10.0 N/A

3 mL disposable pipettes N/A

Whatman pH indicator paper, Type CF (Cat. No. 2614991) N/A

Wash Solution AW11 Made on 9/30/13

Fisher Scientific 2-propanol Lot 132647 N/A (CMS 393143)

Fisher Scientific 2-propanol Lot 132647 N/A (CMS 393145)

N/A

	Volume (mL)	Mass (g)
Deionized water	1700	1690.6
Isopropyl alcohol	1700	1328.0

of NH4OH drops: 20

pH: 8.0 Target pH = 8.0-10.0

Notes: A few hundred mL of AW11 left in bottle.

CMS #393143 empty.

Starting pH between 7.0 and 7.5.

JEF 10/21/13

Entries made by: Julia Flaherty	Technical Data Review performed by: Carmen Arimescu
Signature/date On File w/ Orig 10/21/2013	Signature/date On File w/ Original 3/13/2014

HIGH TEMPERATURE PROBE TESTING - Aerosol Penetration

Aerosol Wash Solution Data

Date **11/1/2013**

Facility **HV-S3**

Time **8:30 - 8:50**

Tester(s) **JEF**

ID **AW13**

Materials and Equipment Used:

Cal Due

Sartorius QS 2000 Lab Balance	S/N 60502077	6/24/2014
VWR 2000 mL graduated cylinder, B, Tol +/- 10.0		N/A
3 mL disposable pipettes		N/A
Whatman pH indicator paper, Type CF (Cat. No. 2614991)		N/A
Wash Solution	AW12	10/21/2013
Fisher Scientific 2-propanol	Lot# 132647	N/A (CMS 393147)
Fisher Scientific 2-propanol	Lot# 132647	N/A (CMS 393153)
N/A		

	Volume (mL)	Mass (g)
Deionized water	1600	1586.7
Isopropyl alcohol	1600	1245.7

of NH4OH drops: **20**

pH: **8.0** Target pH = 8.0-10.0

Notes: ~750mL of AW12 left in bottle.

Emptied 393147.

pH before ammonium hydroxide was btwn 7.0 & 7.5.

JEF 11/1/13

Entries made by: Julia Flaherty	Technical Data Review performed by: Carmen Arimescu
Signature/date On file w/ original 11/1/2013	Signature/date On File w/ Original 3/13/2014

HIGH TEMPERATURE PROBE TESTING - Aerosol Penetration

Aerosol Wash Solution Data

Date	1/15/2014	Facility	HV-S3
Time	14:10 - 14:30	Tester(s)	JEF
ID	AW14		

Materials and Equipment Used:		Cal Due
Sartorius QS 2000 Lab Balance	S/N 60502077	6/24/2014
WWR 2000 mL graduated cylinder, B, Tol +/- 10.0		N/A
3 mL disposable pipettes		N/A
Whatman pH indicator paper, Type CF (Cat. No. 2614991)		N/A
Wash Solution	AW13	11/1/2013
Fisher Scientific 2-propanol	Lot# 132647	N/A (CMS 393155)
Fisher Scientific 2-propanol	Lot# 132647	N/A (CMS 393156)
N/A		

	Volume (mL)	Mass (g)
Deionized water	1000	1050.3
Isopropyl alcohol	1000	774.4
# of NH4OH drops:	10	
pH:	8.0	Target pH = 8.0-10.0

Notes: ~1L of AW13 in bottle

Cylinder weights 1121.7g
 Emptied CMS#393155 (IPA)
 Starting pH ~7.0

/ JEF 11/1/13

Entries made by: Julia Flaherty	Technical Data Review performed by: Carmen Arimescu
Signature/date On file w/ original 1/5/2014	Signature/date On File w/ Original 3/13/2014

Appendix C

LV-S2 Temperature and Humidity Data Sheets

Appendix C

LV-S2 Temperature and Humidity Data Sheets

TDP-WTPSP-636
TH pt of 17
15
7/11/13

HIGH TEMPERATURE PROBE TESTING - Temperature / Humidity Only

Run No. TH-1
Date 7/29/13
Start/End Time 12:00 / 13:00
Testers JEF

Facility / Condition HV-S3 LV-S2 Norm
Chamber Set Point 130°F / 10% RH
Diluter Orientation Horiz or Vert

	Start	Finish	
Time	12:00	13:00	
Chamber Temp	130	130	°F
Chamber Humidity	10	10	RH
Dilution flowcontroller	0.48	0.48	scfm
Dilution Dew Pt	-4	-1	°F
Dilution Temp	82	83	°F
Dilution P	14.5	14.5	psia
Sampling flowcontroller	1.65	1.65	scfm
Sampling Dew Pt	47	47	°F
Sampling Temp	87	87	°F
Sampling P	14.2	14.2	psia
Ambient pressure	996.5	996.1	mbar
Ambient humidity	26%	25%	RH
Ambient Temp	81.5	81.9	°F

Instruments Used:	Cal Due
Thermotron SE-2000-4 Env Chamber S/N 42857	4/2/2014
Type T Thermocouples T001-T006, T009, T008	6/18/2014
Alicat MCR-500SLPM MFC SN 68858	2/4/2014
Alicat MCR-500SLPM-D MFC SN 68857	4/3/2014
Vaisala MI70/HMP77B S/N G5230040/H0320001	1/31/2014
Vaisala MI70/DMP74B S/N G5230040/H0320001	1/31/2014
Mott Corp Diluter 28" oAL Model 7610S-1.375-24-2-AB	N/A
Fisher Dew Point Pen S/N 122277883	5/16/2014
N/A	

Notes: Ran this test right after HV-S3 Min test (TH-1).
The dew point in the chamber during this test is 56°F, so the parts can be dis-assembled without lowering the humidity. No condensation should form in the process of observing 3M dot color.
Used borescope to check 3M dots. They looked white.
Bottom desiccant used for test.

JEF 7/29/13

Data Files
Environmental Chamber Data: 130729_hvs3_min_lv52_norm.csv
Vaisala Dew Point Data (FIO): 2013-07-29_8-59.csv
Alicat Data (FIO): 20130729_0843_alicat.dat

Entries made by: <u>JULIA FLAHERTY</u> Signature/date: <u>[Signature] 7/29/13</u>	Technical Data Review performed by: Signature/date: <u>[Signature] 11/11/13</u>
--	--

TDP-WTPSP-636
TH p16 of 17

HIGH TEMPERATURE PROBE TESTING - Temperature / Humidity Only

Run No. TH-2 Facility / Condition hvs3 LV-S2 Norm
 Date 7/29/13 Chamber Set Point 130°F / 10% RH
 Start/End Time 13:25 / 14:25 Diluter Orientation Horiz or Vert

	Start	Finish	
Time	13:25	14:25	
Chamber Temp	130	130	°F
Chamber Humidity	10	10	RH
Dilution flowcontroller	5.08	5.08	scfm
Dilution Dew Pt	-20	-7	°F
Dilution Temp	82	84	°F
Dilution P	14.7	14.7	psia
Sampling flowcontroller	6.09	6.09	scfm
Sampling Dew Pt	10	13	°F
Sampling Temp	87	86	°F
Sampling P	13.4	13.4	psia
Ambient pressure	995.9	995.6	mbar
Ambient humidity	25%	24%	RH
Ambient Temp	82.1	82.8	°F

Instruments Used:	Cal Due
✓ Thermotron SE-2000-4 Env Chamber S/N 42857	4/2/2014
✓ Type T Thermocouples <u>Too1-Too6, Too9, Too8</u>	6/18/2014
✓ Alicat MCR-500SLPM MFC SN 68858	2/4/2014
✓ Alicat MCR-500SLPM-D MFC SN 68857	4/3/2014
✓ Vaisala MI70/HMP77B S/N G5230040/H0320001	1/31/2014
✓ Vaisala MI70/DMP74B S/N G5230040/H0320001	1/31/2014
✓ Mott Corp Diluter <u>28" oAL</u> Model 7610S-1.375-24-2-AB	N/A
✓ Fisher Dew Point Pen S/N 122277883	5/16/2014
<u>N/A</u>	

Notes: Switched to top desiccant for this test.
Removed one dat. at end of test; no color change w/ water.
on upstream end

7/29/13

Data Files
 Environmental Chamber Data: 130729-hvs3-min-lvs2-norm.csv
 Vaisala Dew Point Data (FIO): 2013-07-29_8-59.csv
 Alicat Data (FIO): 20130729-0843_alicat.dat

Entries made by: JULIA FLAHERTY Technical Data Review performed by:
 Signature/date [Signature] 7/29/13 Signature/date [Signature] 11/11/13

TDP-WTPSP-636
 TH p# of 17
 7/31/13

HIGH TEMPERATURE PROBE TESTING - Temperature / Humidity Only

Run No. TH-3
 Date 7/30/13
 Start/End Time 13:31 / 14:26
 Testers JEF

Facility / Condition LV-S2 Max
 Chamber Set Point 210°F / 6.0% RH
 Diluter Orientation Horiz or Vert

	Start	Finish	
Time	13:31	14:26	
Chamber Temp	209	210	°F
Chamber Humidity	6.1	6.0	RH
Dilution flowcontroller	5.08	5.08	scfm
Dilution Dew Pt	-4	0	°F
Dilution Temp	87	82	°F
Dilution P	14.8	14.8	psia
Sampling flowcontroller	6.09	6.09	scfm
Sampling Dew Pt	35	37	°F
Sampling Temp	92	90	°F
Sampling P	13.9	13.9	psia
Ambient pressure	1001	1001	mbar
Ambient humidity	24	26	RH
Ambient Temp	85.3	80.4	°F

Instruments Used:	Cal Due
Thermotron SE-2000-4 Env Chamber S/N 42857	4/2/2014
Type T Thermocouples T001-T006, T009, T008	6/18/2014
Alicat MCR-500SLPM MFC SN 68858	2/4/2014
Alicat MCR-500SLPM-D MFC SN 68857	4/3/2014
Vaisala MI70/HMP77B S/N G5230040/H0320001	1/31/2014
Vaisala MI70/DMP74B S/N G5230040/H0320001	1/31/2014
Mott Corp Diluter 28" OAL Model 7610S-1.375-24-2-AB	N/A
Fisher Dew Point Pen S/N 122277883	5/16/2014
N/A	

Notes: Using bottom desiccant.
 Heat tape set to 187°F. It's a bit higher due to residual heat from previous tests.
 Took a bit of time to get the chamber in the right spot. Temperature and humidity conditions continue to fluctuate a bit during test.
 Used a borescope to inspect interior. All visible dots appear white. Apparently no condensation.

JEF. 7/30/13

Data Files
 Environmental Chamber Data: 130730_hvs3_norm-lvs2-max.csv
 Vaisala Dew Point Data (FIO): 2013-07-30_9-06.csv
 Alicat Data (FIO): 20130730_0815-alicat.dat

Entries made by: <u>JULIA FLAHERTY</u> Signature/date: <u>[Signature]</u> 7/30/13	Technical Data Review performed by: Signature/date: <u>[Signature]</u> 11/11/13
--	--

Appendix D

Aerosol Aerodynamic Diameter

Appendix D

Aerosol Aerodynamic Diameter

The particle size of the aerosol produced by the vibrating orifice aerosol generator (VOAG) is a function of the aerosol solution concentration, aerosol solution flow rate (which is, a function of the syringe diameter and speed), and frequency of the orifice. The aerodynamic diameter calculation is simplified as the physical diameter multiplied by the ratio of the square root of the aerosol density and unit density. The aerodynamic diameter is calculated as:

$$AD = \left(\frac{6QC_{vol}}{\pi f} \right)^{1/3} \frac{\sqrt{\rho_p}}{\sqrt{\rho_o}}$$

where:

AD = particle aerodynamic diameter, μm ;

Q = liquid volumetric flowrate, $\mu\text{m}^3/\text{s}$;

C_{vol} = volume concentration (particle volume produced per drop volume), dimensionless;

f = frequency of applied vibrational signal, $1/\text{s}$,

ρ_p = particle density, g/cm^3 , and

ρ_o = unit particle density, $1 \text{ g}/\text{cm}^3$.

The production of aerosol during the aerosol penetration tests was monitored with either an aerodynamic particle sizer or an optical particle counter, and in some cases, both. The APS measures the aerodynamic particle size directly; whereas, the OPC measures the optical diameter within user-defined size channels, and post-processing is needed to calculate the aerodynamic diameter. Table D.1 below lists the aerosol solution concentration and VOAG settings, along with the calculated and measured aerodynamic diameters. Note that the APS measurements during LV-S3 are FIO; the instrument was calibrated after these tests were performed. In the region of 10 micron AD, there was an approximately 6% difference between the previous calibration, which was performed under a non-WTPSP project, and the calibration performed in 2013 under this project. Additionally, the OPC AD has been calculated, and these calculations have been formally reviewed with a CCP.

Note that, in general, the calculated and measured AD does not agree. The agreement is better between the calculated and APS-measured values during LV-S3 tests compared with during the HV-S3 tests, and in particular, the second half of the HV-S3 tests. The APS measurements also showed a very narrow band of particle sizes compared with the OPC measurements, which had significant particle counts in several size channels.

Table D.1. Summary of Aerosol Concentration, VOAG Settings, and Calculated and Measured Aerosol Aerodynamic Diameter during LV-S3 and HV-S3 Aerosol Penetration Tests. APS Measured AD values shown are the start and finish values from each test. LV-S3 APS measurements (italicized) are FIO.

Aerosol Solution Concentration (mL/mL)	VOAG Syringe Speed ($\times 10^{-4}$ cm/s)	VOAG Frequency (kHz)	Calculated AD (μm)	APS Measured AD (μm)	OPC Measured AD - FIO (μm)	Run No.
LV-S3						
0.0142	4.6	43.6	11.3	<i>9.6-9.7</i>	11.9	AP-1
		47.2	11.0	<i>9.6-9.6</i>	12.0	AP-2
		48.4	10.9	<i>9.7-9.4</i>	10.8	AP-3
		48.4	10.9	<i>9.6-9.4</i>	10.6	AP-4
		48.4	10.9	<i>10.0-9.7</i>	10.4	AP-5
		48.5	10.9	<i>9.4-9.2</i>	10.6	AP-6
HV-S3						
0.0153	4.6	40.1	11.9	10.2-10.2		AP-1
		40.2	11.9	10.2-9.7		AP-2
		40.2	11.9	9.4-9.5	N/A	AP-3
		40.1	11.9	9.2-9.3		AP-4
		40.1	11.9	9.3-9.0		AP-5
		45.3	11.4	9.4-9.0		AP-6
0.0165	4.7	40.2	12.2	9.0-8.5	N/A	AP-7
0.0323	4.6	41.5	14.9	11.0-10.6	N/A	AP-8
0.0165	4.2	41.5	11.7	N/A	12.8	AP-9
		41.5	11.7	9.3-9.0	11.8	AP-10
0.0323	4.2	41.5	14.4	10.7-11.0	15.4	AP-11
		41.5	14.4	10.8-10.3		AP-12
		41.5	14.4	12.5-11.9	N/A	AP-13
		41.5	14.4	11.0-9.9		AP-14
0.1680	4.2	41.7	24.8	14.5-10.4	N/A	AP-15
0.1677	4.2	55.4	22.8	14.0-13.2	N/A	AP-16

In comparing the APS and OPC measurements in Table D.1, the OPC diameter is always larger than the APS diameter. During LV-S3, the OPC ranged from about 0.5 μm to nearly 2.0 μm larger than the APS diameter. During HV-S3, there were only two tests with both instruments in operation, and the OPC was 2.5 to 4.5 μm larger than the APS measurement. One reason for the differences between the two instruments is the difference in size channels, and the relative differences between certain tests are likely attributable to changes in the prescribed size channels for the OPC. Table D.2 lists the size channels used by the OPC for particles larger than 8.5 μm . (Smaller sizes are similar between tests, and aren't expected to contribute to differences in the mean diameter.) Note that the first two LV-S3 tests had only two size channels between 8.5 and 23.6 μm , while HV-S3 tests had four size channels from 8.5 to 23.6 μm . To illustrate the impact of size channel settings, consider a particle with a diameter of 15 μm . During the LV-S3 AP-1 test, this particle would be counted by the largest bin, between 10.4 and 23.6 μm , and the mean value (average between 10.4 and 23.6) would be 17 μm . During the HV-S3 AP-9 test, however, this particle would again be counted by the largest bin, but this bin is 14.2 to 23.6 μm . The average for this bin is 18.9 μm , which is nearly 2 μm larger than the LV-S3 AP-1 case, and nearly 4 μm larger than the true particle size. The larger mean OPC diameters (relative to the calculated and APS diameters) during the HV-S3 tests is likely attributable to change in size channels during these tests.

Table D.2. OPC Particle Size Channel Setting Comparison

Test	Sizes (AD, μm)				
LV-S3 AP-1 & AP-2	8.5	10.4	23.6		
LV-S3 AP-3 – AP-6	8.5	10.4	12.3	23.6	
HV-S3 AP-9 – AP-11	8.5	10.4	12.3	14.2	23.6

To graphically illustrate the differences between the APS and OPC measurements, and the impact of size channel positions, Figure D.1 shows a comparison of the APS (left column) and OPC (right column) particle size distributions from the LV-S3 AP-2 (top row), AP-3 (middle row), and HV-S3 AP-11 (bottom row) tests. The optical diameters from the OPC have been converted to aerodynamic diameter for this plot. Note that the AP-2 and AP-3 mean particle size with the APS were comparable, while there was a 1 micron difference between the two tests with the OPC. This difference appears to be driven by the large number of particles in the 10.4 to 23.6 μm bin during AP-2. During AP-3, more particles were measured in the 10.4 to 12.3 μm channel. For HV-S3 AP-11, on the other hand, the mean particle size was increased, and according to the APS, particles as large as 17 μm were produced, although most particles were smaller than 14 μm . With the OPC, most particles were in the largest bin, driving a larger mean particle size than the APS. An evaluation comparing additional differences between the APS and OPC has not been performed.

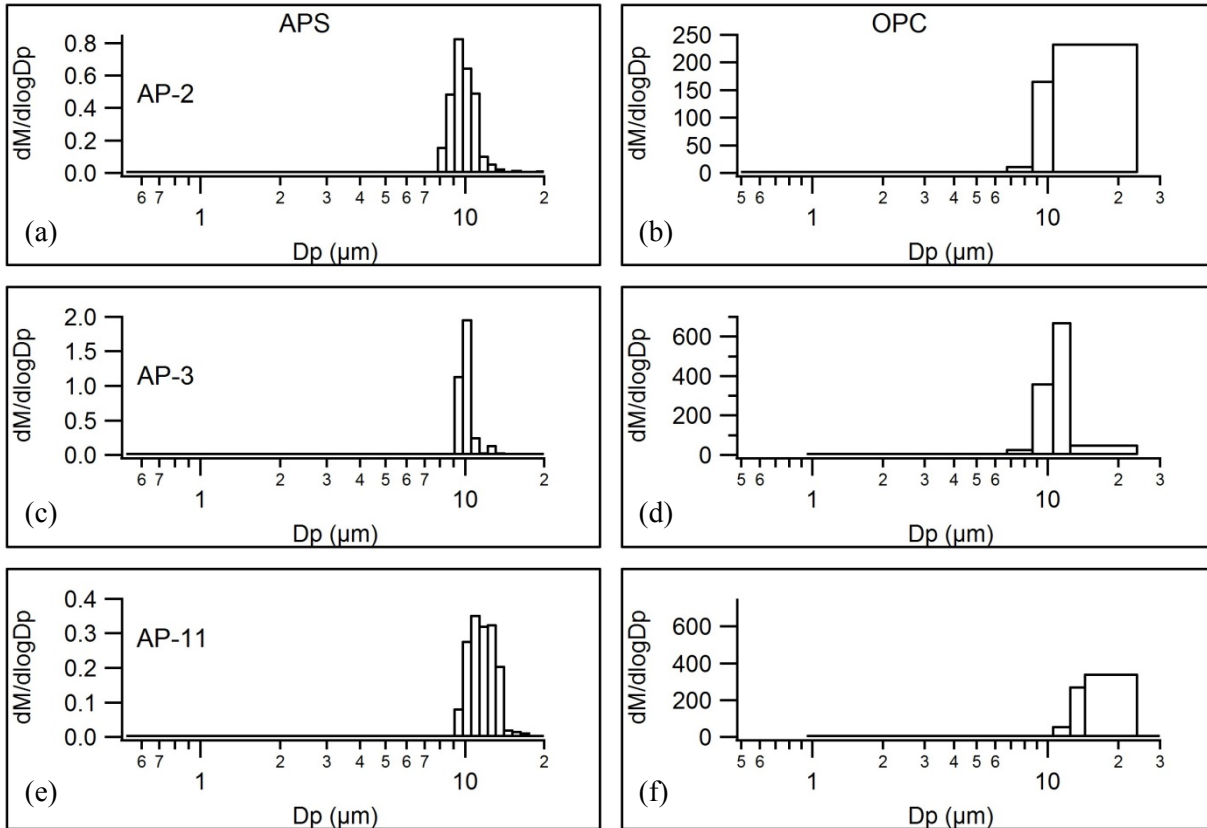

Figure D.1. Particle Size Distribution from the LV-S3 AP-2, AP-3 and HV-S3 AP-11 Tests Measured by the APS and OPC. D_p represents the aerodynamic particle size in each plot. (a), (c), and (e) are from the APS, while (b), (d), and (f) are from the OPC. (a) and (b) are AP-2, (c) and (d) are AP-3, and (e) and (f) are AP-11.

Appendix E

Mott Porous Tube Diluter Quote

Appendix E

Mott Porous Tube Diluter Quote

mott corporation

84 Spring Lane, Farmington, CT 06032-3159
 860-747-6333 Fax 860-747-6739
 www.mottcorp.com

Julia Flaherty
 Pacific Northwest Ntl Lab
 Po Box 999 Msin K6-75
 Richland, WA 99354
 USA
 509-371-7251

Quotation

Quotation #:	QU0200669-2
Customer No.:	CA0012710
Cust Reference #:	
Payment Terms:	Net 30 days
IncoTerms:	EXW
Date:	06/05/2013
Page:	1 of 1

Line	Item Number / Description	Customer Ref Part No.	Lead Time ARO	Qty	U/M	Unit Price
1	TBD 7610S-1.375-24-2-AB S=3/4"OD SAMPLE LINE MOTT 7610 SERIES IGS FILTER ASSEMBLY: POROUS OD = 1.5" (use .062" rolled and welded sheet tube) POROUS NOMINAL ID = 1.375" POROUS LENGTH = 24" OAL = 32" SAMPLE LINE OD = 3/4"OD (POSITIONED 6" FROM INLET) MEDIA GRADE = 2 POROUS MATERIAL = 316LSS HARDWARE MATERIAL = 316SS IGS FILTER ELEMENT MOUNTED IN HOUSING HOUSING LENGTH SHOULD BE THE MINIMUM REQUIRED TO PROVIDE FOR WELDING CUSTOMER REQUESTS MINIMAL AMOUNT OF EXPOSED SOLID TUBING ON THE INSIDE OF THE UNIT SAME AS 7610019-020 EXCEPT SOLID TUBE LENGTHS ON EACH END OF THE ELEMENT ARE TO BE 4" L FOR A 32" OVERALL LENGTH		6-8 weeks ARO	1	EA	

If you have any questions or require further information, please do not hesitate to contact us.

Thank you for your inquiry.



Robert Saunders
 Applications Engineer

Certification:

Material certification is available upon request at time of original order placement, whether verbal or written, for a fee of \$30.00 per order. It may be possible to provide certifications after the initial order is processed, and when necessary, a charge of \$100.00 will apply.

Please Note the Following:

Minimum order requirement: US\$500.00.
 Incoterms: EXW Farmington, CT USA.
 Payment Terms: Net 30 Days upon approval.
 Wire transfer details available upon request.
 MasterCard and Visa are accepted.

Pricing on this quotation is based on existing stock levels.
 A new quotation may be necessary in the event stock levels change.
 Mott standard tolerances and manufacturing conditions apply unless otherwise noted.
 Quotation valid for 60 days from date of issue.

Appendix F
Document List

Appendix F Document List

Project Plan	PP-WTPSP-053	Tests of a High Temperature Sample Conditioning System for the Waste Treatment Plant LV-S2, LV-S3, HV-S3A and HV-S3B Exhaust Systems
Test Plan	TP-WTSP-052 Rev 0.	Tests of a High Temperature Sample Conditioning System for the Waste Treatment Plant LV-S2, LV-S3, HV-S3A and HV-S3B Exhaust Systems
Laboratory Record Book	BNW-61301	WTP Stack Qualification Testing – High Temperature Probe
Test Data Package	TDP-WTPSP-635	Tests of a High Temperature Sample Conditioner for the Waste Treatment Plant LV-S3 Exhaust System
	TDP-WTPSP-636	Tests of a High Temperature Sample Conditioner for the Waste Treatment Plant HV-S3A and HV-S3B Exhaust System
Calculation Packages	CCP-WTPSP-1313	High Temperature Probe LV-S3 Aerosol Penetration Test Calculations
	CCP-WTPSP-1314	High Temperature Probe HV-S3A and HV-S3B Aerosol Penetration Test Calculations
	CCP-WTPSP-1121	Mean Aerosol Aerodynamic Diameter Calculations from an Optical Particle Counter

Distribution

**No. of
Copies***

OFFSITE

3 Bechtel National, Inc.	
PA Douglass	H4-02
MM Mwembeshi	H4-02
WTP Docs	H4-02

ONSITE

6 Pacific Northwest National Laboratory	
JA Glissmeyer	K3-54
JE Flaherty	K9-30
RA Peterson	P7-22
JM Barnett	J2-25
Information Release	K3-52
Project File	K3-52

* All distribution will be made electronically.



Pacific Northwest
NATIONAL LABORATORY

902 Battelle Boulevard
P.O. Box 999
Richland, WA 99352
1-888-375-PNNL (7665)

www.pnl.gov



U.S. DEPARTMENT OF
ENERGY