



Upgrading Linear Fluorescent Fixtures to LED in Schools

U.S. Department of
ENERGY | Office of Energy Efficiency
& Renewable Energy

November 2024

Summary

Lighting is a key component to creating a functional and high-quality learning environment for students and staff. Light-emitting diode or LED lighting fixtures have gained traction in many commercial building applications and quality replacement options for common fixture types are widely available. Compared to most fluorescent lighting systems, LED systems can reduce energy consumption and therefore decrease carbon dioxide emissions at scale, reduce maintenance and operation costs, and improve the visual appearance and lighting quality of the classroom and school environments. When additional controls are considered, more energy can be saved and some controls, like dimming, can offer amenities to occupants.

As LEDs become an even more prominent lighting technology, fluorescent equipment may become challenging or expensive to replace if or when manufacturers decide to decrease fluorescent production. School buildings are typically in use for many decades; maintaining a long-term view can be important when deciding which upgrade path to take. This document provides guidance on the various factors to consider when deciding on an LED upgrade for fluorescent lighting systems.

Introduction to Linear Fluorescent Lighting: Options for Upgrades

Linear fluorescent lamps became a common lighting solution beginning in the 1950s due to the energy efficiency gains and increased lifetime compared to incandescent lamps. In response to the increasing popularity of fluorescent technology, manufacturers began designing fixtures to accommodate standard four-foot linear fluorescent lamps in the form of troffers, pendants, strip lights, and wrap around fixtures. One or more of these fixture types, illustrated in Figure 1, can be found in nearly every K-12 school building.

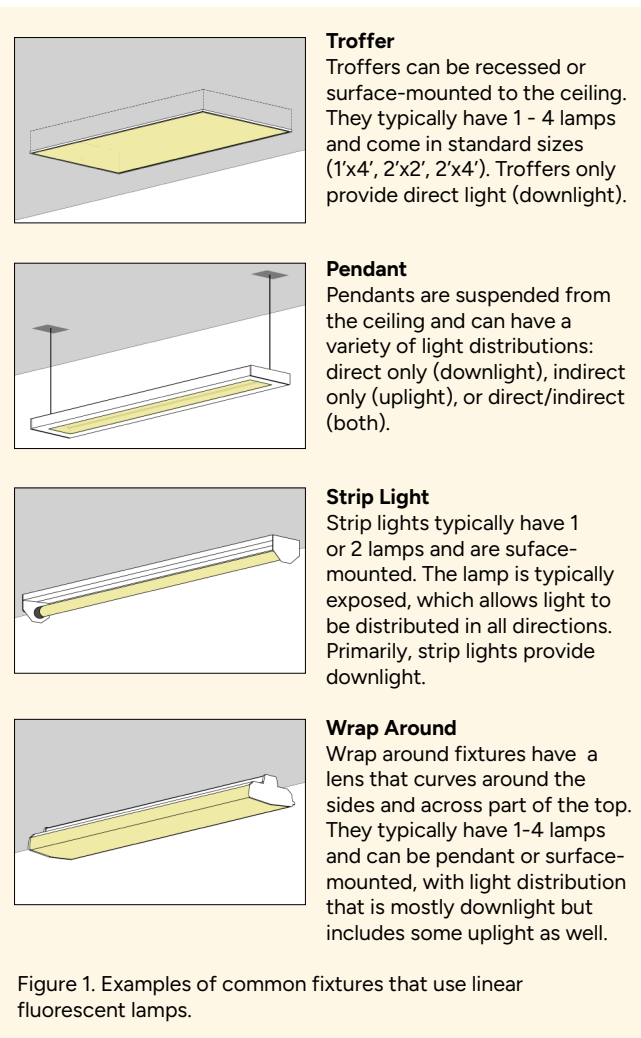

In the 2010s, LEDs began to gain popularity for interior lighting and manufacturers once again created products that considered the dominant stock of existing fixtures, which were designed to accommodate standard fluorescent lamps. There are three primary LED options for upgrading lighting systems that use linear fluorescent lamps:

1. Lamp – Replace only the fluorescent lamps with tubular LEDs (TLEDs). The three types of TLED replacement lamps are briefly described below.
2. Retrofit Kit – Remove the fluorescent lamps and other fixture components and replace with an LED retrofit kit that fits into the existing housing.
3. New Luminaire – Replace the entire fluorescent luminaire or fixture, including the housing, with a new LED luminaire.

Types of TLEDs

Tubular LEDs (TLEDs) are LEDs that match the form factor (diameter, length, and base) of fluorescent tubes so they can plug into the existing sockets in a fluorescent fixture. Existing fluorescent fixtures use a ballast to control current to the lamps and to start

the lamps, whereas TLEDs require a driver to provide proper current and power management. Underwriters Laboratories (UL) defines three types of TLEDs:

1. UL Type A – The sockets remain wired to a new or existing fluorescent ballast; the TLED has an internal driver designed to operate on the ballast output voltage. No re-wiring is needed.
2. UL Type B – The wiring to the existing fluorescent ballast is terminated as well as the wiring from the ballast to the sockets. The sockets are rewired for direct connection to the branch circuit, and the TLED has an internal driver that is designed to operate on the line voltage supplied to the fixture.
3. UL Type C – The TLEDs have an external driver that operates on line voltage; electrical connections to the existing ballast are terminated and the line voltage and sockets are connected to the new external TLED driver. The external driver can drive multiple TLEDs and provides better thermal management than internal drivers, which may contribute to a longer lasting lamp. The TLEDs do not have an internal driver.

See Figure 2 for schematic diagrams for each TLED replacement option.

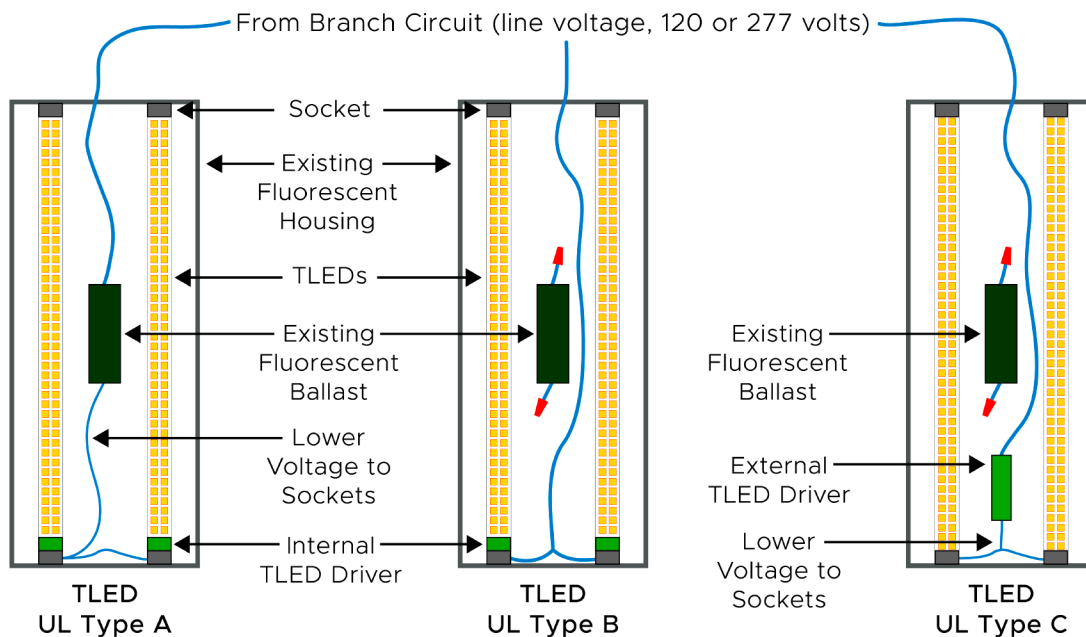

Figure 2. TLEDs can fit into existing sockets. UL Type A TLEDs use the existing fluorescent ballast. UL Type A and B TLEDs have internal drivers while UL Type C TLEDs use external drivers.

Table 1 provides the pros, cons, and estimated energy savings relative to a fluorescent lighting system for each upgrade option. In addition to considering the overall benefits and drawbacks of each technology,

selecting the best option for an installation also depends on the initial and ongoing economic goals for the upgrade, the desired lighting quality and control capability, and the condition of the existing equipment.

Table 1. Comparison of LED options for retrofitting light fixtures with linear fluorescent lamps.

LED Replacement Options		Pros	Cons	Potential Energy Savings Estimate ¹
LAMPS	Type A In-Line Ballast "Plug and Play"	Can use existing ballast and sockets. If using existing ballast, no rewiring or electrician required. Low shock risk. Fast installation. Lowest first cost. Good option for limited ceiling access.	Relies on fluorescent ballast and aging equipment; may be difficult to find ballast replacement in the future. Must check lamp compatibility with ballast. Possible flicker. May not be dimmable. Least efficient of TLED options.	20%
	Type B Line Voltage Bypass Ballast	Does not rely on existing ballast. Greater energy savings than Type A TLED. Low first cost on equipment. Quick installation. Good option for limited ceiling access.	Requires electrician to connect line voltage directly to sockets. The fixture modification requires a label to protect maintenance staff from potentially fatal shock hazard when replacing TLEDs in the future. Not recommended for schools that regularly experience power surges or interruptions. Possible flicker.	30-50%
	Type C Line Voltage External Driver	Safer than Type B; lower voltage from driver to sockets. No compatibility issues. External driver provides better thermal management. Easier to add controls. Slightly lower cost than retrofit kits. Most efficient of the TLED options. Good for limited ceiling access.	Requires electrician to modify existing wiring. Not as efficient as retrofit kits. Higher first cost on equipment than other TLED options. Requires labeling to remind maintenance staff that the fixture has been modified when replacing TLEDs in the future. Can limit the project to a specific equipment manufacturer.	30-50%
LED RETROFIT KITS		Uses existing housing but replaces old lamps, ballasts, and sockets with new electronics and LED modules for longer life. Better heat management and lower failure potential than TLEDs. Higher efficiency compared to TLEDs. Can add lighting controls. Good option for limited ceiling access.	Requires an electrician. Higher equipment and labor costs than TLEDs. Some troffer fixture designs are more difficult to retrofit because the fixture housing is contoured around the lamps.	40-60%
NEW LED LUMINAIRES		Provides high potential energy savings. Fixture is designed to optimize LED source performance. Widest range of options for adding lighting controls. Could add non-lighting capabilities. Lowest failure potential; longest lasting. If existing equipment is in poor condition, complete replacement may be the only option.	Requires an electrician. Most expensive for equipment and labor, but differences may not be substantial. Will most likely require access above the ceiling; potential health hazards if there is asbestos in the ceiling. Requires disposal of removed luminaires.	40-60%

1. PNNL estimated energy savings assuming a fluorescent baseline.

System Factors to Consider

An evaluation of LED upgrade options includes assessing the system costs and the effects on the lighting system performance. Table 2 summarizes several key factors, and the sections following the table explain those factors. The column heading Lamps refers to TLED replacement lamps; the heading Kits

refers to LED retrofit kits; and the heading Luminaires refers to new LED luminaires. For each of the three LED upgrade options, the table provides a color-coded identification of whether a factor is favorable for the related LED option (green circle), whether there may be reasons to exercise caution based on this factor (yellow triangle), or whether there may be significant barriers to implementing the related LED option based on this factor (red square). *Note that the performance of the products available within each of the LED options varies and each individual product must be evaluated on its own merits.*

Table 2. System factors to consider for LED lighting upgrades.

System Factors to Consider	Description	LAMPS			KITS	LUMINAIRES
		Type A In-Line Ballast "Plug and Play"	Type B Line Voltage Bypass Ballast	Type C Line Voltage External Driver		
Initial Costs	Equipment purchase costs	\$	\$	\$	\$\$	\$\$-\$\$\$\$
	Installation labor costs	\$	\$\$	\$\$	\$\$	\$\$-\$\$\$\$
	Installation time	<5 minutes	15 minutes	15 minutes	15-30 minutes	30 minutes
Operating Costs	Energy costs for equal light output	■	■	■	▲	●
	Replacement costs over system life	▲	▲	▲	▲	▲
Safety Considerations	Shock hazard and fixture labeling requirements	●	■	■	●	●
Current Light Levels	Acceptable; should not be reduced at all	▲	▲	▲	▲	▲
	Reductions of 10% or more are okay	●	●	●	●	●
Lighting Controls	Interested in dimming only	■	■	▲	▲	▲
	Interested in upgrading or integrating controls	■	■	▲	●	●



Favorable for LED



Use Caution with LED



Significant Barriers with LED

Initial Costs

Equipment Purchase Costs

TLED replacement lamps often provide the lowest cost option in terms of purchasing the LED components. LED retrofit kits usually cost more than replacement lamps, and new LED luminaires typically have the highest cost. Comparing the costs of LED retrofit kits and new luminaires can be useful, as the price difference may not be substantial. However, if the existing luminaire housing is in good condition, retrofit kits that use the existing housing can reduce material waste. Although new luminaires are typically the most expensive, this option is likely to provide both the highest efficiency and effectiveness because the fixture components and housing shape are designed to maximize light output from an LED light source. Replacing the entire system with new luminaires is also likely to be the longest lasting solution.

Installation Labor Costs

Replacement lamps that simply snap into the existing fluorescent lamp sockets provide the lowest labor costs for installation. However, some products marketed as replacement lamps, particularly UL Type B and C, require further modifications to the fixture and will have labor costs similar to products marketed as retrofit kits. For example, UL Type A TLEDs do not require wiring modifications, but Type B and C TLEDs do require modifications. In some cases, sockets and/or ballasts may need to be replaced by an electrician even for simple Type A TLED replacements, which will increase the installation cost.

Labor costs for installing retrofit kits are generally higher than those for replacement lamps and, depending on the extent of the fixture modifications required, may approach or even exceed the labor costs for installing new LED luminaires. Labor costs for replacement lamps and retrofit kits are sometimes underestimated (e.g., when an electrician must perform additional wiring modifications and remove components). Fluorescent lamps require appropriate disposal, and some older systems have ballasts that contain PCBs, a hazardous substance that requires

proper handling and disposal,¹ which can add to the installation costs.

Although the electrical components (ballasts, sockets, and wiring) of the fixture are disconnected and, in most cases, removed with retrofit kits, retrofit kits allow for the fixture housing to remain in place which is a significant time-saving feature. The biggest disadvantage of new luminaires is the need to remove the housing from the ceiling, which increases labor costs and may expose hazardous materials, such as asbestos.

Operating Costs

Energy Costs

For retrofit projects that retain the existing number of fixtures and control scheme, energy costs depend on the wattage of the fixture with the new components installed relative to the existing fixture. But in some cases, the retrofit products offering the greatest wattage reductions also deliver much less light than the existing system. This may be acceptable—see the discussion on light levels—but to compare across the categories of LED options, Table 2 assesses energy costs for equal fixture output. UL Type A TLEDs are the least efficient replacement option because use of the existing fluorescent ballast limits the energy efficiency of the fixture.

Replacement Costs and Material Waste

Ongoing replacement costs depend on the product and labor costs as well as how often the light sources (fluorescent or LED) and related auxiliary equipment (ballasts or drivers) need to be replaced. If sustainability directives are motivators for the upgrade, the component life cycle and waste produced by each replacement option should be considered. Consider the following outcomes when deciding which upgrade path to take:

- UL Type A TLED: The fluorescent ballast and the TLED lamps will need to be replaced at end of life, similar to fluorescent lighting systems.

¹ "Proper Maintenance, Removal, and Disposal of PCB-Containing Fluorescent Light Ballasts", EPA, <http://www.epa.gov/epawaste/hazard/tsd/pcbs/pubs/ballasts.htm>.

- UL Type B TLED: The lamps will need to be replaced at end of life, but there is no external ballast or driver to maintain or replace since Type B TLEDs are directly connected to line voltage.
- UL Type C TLED: Both the lamps and the LED driver will need to be replaced at end of life.

At some point, the fluorescent housing or sockets will degrade or fail. If fluorescent fixtures and replacement components are not available, replacement lamps may no longer be a suitable option.

- Retrofit kits and new luminaires: The upgrade will likely need to be repeated at end of life. Some components, such as the driver, may be replaceable or serviceable without removing or replacing the fixture. Failure of the LED modules in a sealed housing typically requires replacement of the entire fixture.

Because the expected replacement frequency and costs require careful assessment for each application, Table 2 shows the LED options as yellow for this category.

Safety Considerations

While new luminaires already have the required safety certifications, other replacement options may require modifications during installation that require additional safety inspection and special labeling. An onsite inspection and certification may be required at an additional cost.

UL Type B LEDs have the highest safety risk because they require line voltage directly to the sockets. A licensed electrician should be prepared to appropriately manage these risks. During installations, the electrician is required to put a label on every fixture indicating that the fixture has been modified and that a potential shock and fire hazard exists. The label serves as a reminder that the lamp should not be replaced with a fluorescent lamp, or replaced with a UL Type A TLED, during future relamping. For safety, it is best practice not to use both Type A and Type B

TLEDs in the same building. The TLEDs look similar, and if a Type A TLED is installed in a fixture re-wired for a Type B TLED it will supply line voltage to the Type A TLED. Electric arc, shocks, or even bursting TLEDs are possible. Because of the high voltage, a shock could cause serious injury or death.

In most cases, the act of modifying the existing fixture will void any original warranty. A label should be provided with the equipment by the lamp or fixture manufacturer. Figure 3 shows an example fixture label.

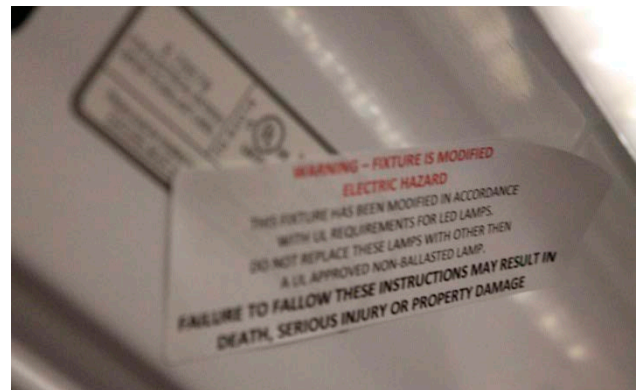

Figure 3. Some replacement options require the existing fixture wiring to be modified by an electrician. The replacement lamps (UL Type B or C) or retrofit kit should include a label like the one shown here to communicate the risks associated with the modification. The label should be visible to maintenance staff servicing the fixture. *Photo courtesy of Michael Myer, PNNL.*

Current Light Levels

Many installed fluorescent systems provide more light than current standards require and selecting an appropriate LED upgrade option depends on an assessment of current light levels and the extent to which they may be reduced. In cases where the existing light levels must be maintained, LED options should be evaluated using luminaire efficacy ratings (in terms of lumens/watt) or the estimates shown in Table 3. In cases where the light levels can be reduced, the greatest savings may result from reconfiguring the layout to use fewer fixtures. While it is possible to reuse existing fixture housings that are in good condition, new luminaires that optimize the new layout and resulting light levels might best suit a redesign of this nature. A mock-up installation may be needed to assess the light levels beneath and between fixtures.

Additionally, several free, online software tools allow for simple lighting calculations that approximate light levels based on specific fixture, lamp, and spacing criteria. Results of these calculations are shown in footcandles or lux, both of which measure illuminance (i.e., the amount of light falling on a surface). The Illuminating Engineering Society provides recommendations for illuminance levels and suggests 30–50 footcandles, or 300–500 lux, on the desks or task surfaces in classroom applications.

Light distribution also needs to be evaluated. LEDs have distribution characteristics that can increase the chances of glare from the fixture or reduce light on the ceilings or walls, compared to fluorescent sources. Maintaining vertical light levels is important in classrooms to ensure the educator, whiteboard, or walls used to display teaching material are sufficiently illuminated. If possible, the light distribution should be tested in a real space before completing a building-wide retrofit. If large furniture or cabinets have been added to classrooms or the main teaching area has changed, it may be beneficial to modify the layout or light distribution to avoid obstructions, or appropriately light the teaching area for AV displays.

Some pendant fixtures with an indirect and direct component (i.e., up toward the ceiling and down toward the room) may be challenging to replace with TLEDs due to the more complicated optical design. A new luminaire may be the best upgrade option.

Dimming

LED dimming performance is determined by the driver and its compatibility with the light source and the dimming equipment, which includes a dimmable wall switch. First, the LED products and drivers need to be dimmable; this will be described in the product literature. Second, occupants need a way to control the dimmable products. This requires installation of a wireless control system with integrated communication and new wall switches, or it requires the addition of a traditional dimmer switch wired to compatible LED drivers. Some combinations of LEDs, drivers, and dimmers can produce noticeable flicker, so retrofit kit and new luminaire options have been designated yellow in Table 2. Product samples of the exact configuration desired should be evaluated throughout the dimming range to assess the possibility of flicker and color shift.

Providing dimming in classrooms allows teaching staff to reduce or turn off lighting during audiovisual lessons and enhances the flexibility of the learning environment. While dimming can give teachers greater control over the classroom environment, it may not be feasible in every case. If possible, prioritize dimming in special education classrooms, counseling rooms, and the nurse’s office. Separate switching of fixtures closest to the board may be a reasonable alternative to providing dimming in classrooms.

Table 3. Estimation of typical fluorescent fixture light output and suitable LED replacements. If the existing fixtures are 2’x4’ troffers with 2 lamps, a retrofit kit or new luminaire replacement should have a total light output between 2,500 and 4,000 lumens. For a 2-lamp TLED replacement, assume each lamp emits 2,500 lumens for a total light output of 5,000 lumens per fixture.

Existing Troffer Configuration	Retrofit Kits and New Luminaires Light output listed in lumens				TLED Replacement in Linear Fixtures
	1 Lamp	2 Lamps	3 Lamps	4 Lamps	
1' x 4'	1,000 – 1,500	3,000 – 4,000	4,500 – 6,000	NA	Assume each lamp has an output of 2,500 lumens
2' x 2'	NA	2,500 – 3,500	NA	NA	
2' x 4'	NA	2,500 – 4,000	4,000 – 5,000	6,000 – 7,500	

NA = No applicable models exist

Glare

Brightness is a perception that is related to the amount of light emitted by a fixture. Two fixtures can have the same lumen output, yet one can appear brighter than the other. The reasons for differences in perception of brightness include distribution, color appearance, optical design, and glare. Fixtures should be evaluated before installation to prevent complaints that the lighting may be too bright. Fixes to reduce brightness can also reduce illuminance, which could result in complaints that the lighting level is too low.

Flicker

Flicker is the constant fluctuation of light output from 0% to 100%. Virtually all humans perceive flicker when the frequency is 80 hertz (Hz) or lower; some can perceive it between 80 and 100 Hz and others can perceive it at frequencies into the thousands. Factors that could introduce flicker in an LED include the electrical supply, the LED driver, a dimming system, and – when using TLEDs – possibly the existing fluorescent ballast. The industry is working on a suitable metric for flicker. At this time, the best method for determining whether flicker is occurring and whether it is acceptable is to install the product and observe it. Sensitivity to flicker can vary from person to person so even if you do not observe flicker, others still might experience it.

Color Quality

Although not included in Table 2, the color quality of the LED upgrade is an important consideration. All of the LED categories offer products with a selection of correlated color temperatures (CCT), and all offer products with color rendering index (CRI) values in the 80s and higher, similar to fluorescent lamps. LED products with poor color quality are available, often at low cost, so CCT and CRI values should be evaluated, and product samples should be visually evaluated to assess any noticeable differences in color quality. Although CCT is not an indication of quality, it needs to be evaluated visually to avoid unpleasant surprises.

Lighting Controls

All upgrade options, including TLEDs, will work with existing, in-line lighting controls such as time-based controllers, occupancy sensors or photocell controllers in an on/off capacity. Retrofit kits offer greater energy savings potential from lighting controls compared to TLEDs and the retrofit kit body provides a physical location to mount new sensors. Installing new luminaires offers the most options for lighting controls and most lighting fixture manufacturers also offer scalable control systems that work with their suite of products. New luminaires with an advanced lighting control system can not only support lighting functionality beyond dimming, such as preset scene control or task tuning, they can also support detailed scheduling opportunities, provide remote access and monitoring, and share information beyond the lighting system.

Lighting controls like occupancy sensors and daylight sensors can significantly add to the energy savings captured by a retrofit project. Sensors can be hard-wired to the fixture or wireless and battery powered. Many fixture manufacturers now incorporate one or more control mechanisms, such as sensors, in their LED products. Retrofit kits or new luminaires with integrated controls provide additional control options with no additional labor costs as the sensors are already connected for a small increase in equipment cost.

Virtually all energy codes in use today require some form of lighting control beyond a local switch in each room. Energy codes from the local jurisdiction should always be reviewed; many jurisdictions reference a specific code year of ANSI/ASHRAE/IES Standard 90.1 titled, “Energy Standard for Buildings Except Low-Rise Residential Buildings” or the International Energy Conservation Code (IECC), but there may be local modifications to consider. Regardless, automated or scheduled shutoff is a common requirement. In general, any lighting alteration beyond replacing the lamps should comply with shutoff requirements, which state that lighting systems shall turn off during periods where the building is scheduled to be unoccupied or when the system receives a signal from a schedule, occupancy sensor, or input from a control or alarm system that the building is unoccupied. As of 2016

code standards, alterations including new luminaires are required to comply with all relevant space-by-space requirements. Space-by-space requirements include control strategies such as occupancy sensing, daylight responsive dimming, or shutoff requirements. In the 2022 release of ANSI/ASHRAE/IES Standard 90.1, projects greater than 2,000 W must comply with all relevant space-by-space requirements, regardless

of which LED technology is selected. Table 4 provides information on how energy codes may apply to a project.

To find a specific state’s or territory’s energy code, visit: <https://www.energycodes.gov/>. Select the state from the dropdown on the right side to view state-specific energy code information.

Table 4. Summary of lighting control capabilities offered by each upgrade type: TLEDs (lamps), retrofit kits (kits), or new fixtures (luminaires). Energy code requirements will vary depending on the reference code year as well as the upgrade path selected.

System Factors to Consider	Description	LAMPS			KITS	LUMINAIRES
		Type A In-Line Ballast "Plug and Play"	Type B Line Voltage Bypass Ballast	Type C Line Voltage External Driver		
Lighting control capability	Integral sensors available	None	None	None	Many	Many
Space-by-space control requirements (ANSI/ASHRAE/ IES Standard 90.1 Code Version/ IECC Code Version)	90.1-2007/2009 IECC	Space-by-space control requirements only apply to new control devices and do not apply to any luminaire upgrades				
	90.1-2010/2012 IECC	No requirements	Must comply with Automatic Shutoff requirements			
	90.1-2013/2015 IECC	No requirements	Must comply with Automatic Shutoff requirements			
	90.1-2016/2018 IECC	No requirements	Must comply with Automatic Full Off or Scheduled Shutoff requirements			Must comply with all applicable space-by-space requirements
	90.1-2019/2021 IECC	No requirements	Must comply with Automatic Full Off or Scheduled Shutoff requirements			Must comply with all applicable space-by-space requirements
	90.1-2022	If the total new and retrofitted wattage is greater than 2,000 W the system must comply with all applicable space-by-space requirements If the total wattage is less than 2,000 W the system must comply with Local Control, Automatic Full Off, and Scheduled Shutoff requirements				

Existing Conditions to Consider

Lighting systems change over time. Many of these changes degrade the performance of the system, usually resulting in a reduction in light output. Some of these light losses are recovered through routine maintenance (e.g., the light output of fluorescent lamps slightly decreases over their lifetime but is restored to the initial levels when the lamps are replaced). Similarly, the light output from the fixture will be reduced by the normal accumulation of dust and particulates on the fixture; these light losses can be restored through simple cleaning.

Other factors that may degrade lighting system performance over time cannot be addressed through routine maintenance. Degradation of reflector, lens, and louver surfaces may result in a reduction in the

amount of light being reflected or transmitted. This reduction is sometimes accompanied by a yellowing of the materials or by painted surfaces becoming scratched or peeling. Electrical components such as lamp sockets and wiring also degrade, in some cases affecting the long-term performance of the lighting system. Normal replacement of lamps and cleaning of fixtures does not address these long-term degradations in system performance. If the existing equipment is in poor condition, a retrofit kit or total fixture replacement may be the only options.

In addition to the system factors shown in Table 2, the existing condition of the installed lighting system can affect which LED upgrade option may be most suitable. Table 5 identifies some of the important parameters and uses the same column headings and color-coding scheme shown in Table 2. Note that the performance of the products available within each LED category varies and each individual product must be evaluated on its own merits.

Table 5. Existing conditions to consider for LED upgrades.

System Factors to Consider	Description	LAMPS			KITS	LUMINAIRES
		Type A In-Line Ballast "Plug and Play"	Type B Line Voltage Bypass Ballast	Type C Line Voltage External Driver		
Condition of sockets	Look new	●	●	●	●	●
	Some wear but no major cracks	▲	▲	▲	●	●
	Look old, blackened, cracks apparent	■	■	■	●	●
Condition of interior surfaces	Look new, no scratches	●	●	●	●	●
	Slightly worn but no major scratches or peeling paint	▲	▲	▲	▲	●
	Very worn, scratched and/or peeling paint	■	■	■	▲	●

continued

System Factors to Consider	Description	LAMPS			KITS	LUMINAIRES
		Type A In-Line Ballast "Plug and Play"	Type B Line Voltage Bypass Ballast	Type C Line Voltage External Driver		
Condition of lens or louvers	Look new; very little wear apparent	●	●	●	●	●
	Some minor color variations or scratches in surface	▲	▲	▲	▲	●
	Look old, obvious cracks or yellowing	■	■	■	■	●
Ceiling access	No concerns about working above the ceiling; easy access	●	●	●	●	●
	Some concerns about working above the ceiling; limited access	●	●	●	●	●
	Working above the ceiling should be avoided	●	●	●	▲	■

● Favorable for LED
▲ Use Caution with LED
■ Significant Barriers with LED

Condition of Sockets and Other Components

Many replacement lamp products are designed to be installed in the existing fluorescent sockets (also known as tombstones), which may or may not be in suitable condition for those lamps. If the condition of the sockets causes any doubt about using replacement lamps, a visual inspection of the sockets by an electrician often is sufficient to determine whether socket replacements or other modifications are necessary as part of the upgrade. If considering a TLED upgrade, the existing sockets may need to be replaced regardless of their condition or age. Fluorescent fixtures use shunted or non-shunted sockets depending on the type of ballast. Type A TLED lamps most commonly use shunted sockets, while Type B and Type C TLED lamps typically use non-shunted sockets.

In addition to the sockets, the existing fluorescent ballast should also be inspected if Type A replacement lamps are considered. If the existing ballast has been in use for 5 years or longer, UL Type A TLED lamps are not recommended for use with the existing ballast. The cost of replacing the ballasts should be weighed

over the remaining life of the system. In the future, fluorescent ballasts may become more expensive or more challenging to find. Furthermore, as fluorescent ballasts age, they may cause flicker in some Type A TLED replacements. If possible, potential lamp replacement options should be tested with the existing ballasts.

Condition of Interior Surfaces

The interior painted surfaces of older fixtures may have significantly degraded or been damaged over time, and some LED upgrade options will not correct those issues. LED replacement lamps may be viable as a short-term solution if the interior degradation is not severe, but with significant degradation, replacement lamps are not recommended. Some LED retrofit kits provide new reflector surfaces that mostly or completely cover the existing surfaces; the yellow designation in Table 5 indicates that a sample should be evaluated to ensure that the new reflector completely covers the degraded surfaces. A visual inspection of the fixtures can usually determine the extent of the modifications needed. The costs of any additional components should be included in the economic analyses for the system.

Condition of Lenses or Louvers

Similar to the interior surfaces of the existing fixtures, optical media such as lenses or louvers may also degrade or be damaged over time. Some of these materials turn yellow after years of use, and some specular or reflective materials show color separation and variations in specularity. Some materials become scratched from improper cleaning techniques or from handling during relamping. If the degradation is minor, replacing or removing these components can be part of an installation of replacement lamps or retrofit kits – if new components are not included as a standard part of the upgrade. With more significant deterioration, replacement lamps or retrofit kits are only viable if the degraded components are also replaced. The costs of these additional components need to be included in the economic analyses for the system.

Ceiling Plenum Access

In some existing buildings, lighting system upgrades that require access into the ceiling plenum raise a number of concerns, from convenience and ease of access to health concerns related to potentially harmful materials that may be present. In these cases, replacement lamp and retrofit kit solutions that can be installed without above-ceiling access may be suitable, while installing new luminaires may be difficult if the above-ceiling access or amount of space is limited. In cases where any access or disturbance of the existing ceiling is prohibited, new luminaires are unlikely to be viable. Installation instructions for the upgrade options being evaluated should be reviewed to determine the extent of required access.

Linear Fixture Performance Criteria

Several groups establish performance criteria for fixtures that use LED technology. The Better Buildings Alliance² (BBA), a collaborative effort between the U.S. Department of Energy and owners, operators, and managers of commercial buildings, provides fact sheets, specifications, and webinars related to high efficiency troffer lighting and other building energy products. The DesignLights Consortium (DLC) develops specifications for high efficiency, high quality commercial lighting solutions and maintains lists of qualified products that satisfy the specification requirements. Many utility rebate programs reference the DLC's technical performance guidelines or qualified product lists.

Both the BBA and DLC also establish minimum lumen output levels for different fixtures. The DLC³ uses the same performance criteria whether the product is a dedicated LED luminaire, a fluorescent fixture with an LED retrofit kit installed, or a fluorescent fixture with LED replacement lamps installed. For LED replacement lamps, the DLC also requires a minimum bare lamp efficacy of 110 lm/W.

Regardless of which upgrade path is selected, it is best practice to compare products or prepare a sample upgraded classroom for evaluation prior to completing an entire lighting upgrade. *For further specification and performance guidelines, see [Specification Guidance for Schools](#).*

2 The Better Buildings Alliance lighting resources may be accessed at: <https://betterbuildingssolutioncenter.energy.gov/alliance/technology-solution/lighting-electrical>.

3 The DLC Technical Requirements and related qualified product lists may be accessed at: <http://www.designlights.org/>.

DISCLAIMER

This report was prepared as an account of work sponsored by an agency of the United States Government. Neither the United States Government nor any agency thereof, nor Battelle Memorial Institute, nor any of their employees, makes **any warranty, express or implied, or assumes any legal liability or responsibility for the accuracy, completeness, or usefulness of any information, apparatus, product, or process disclosed, or represents that its use would not infringe privately owned rights.** Reference herein to any specific commercial product, process, or service by trade name, trademark, manufacturer, or otherwise does not necessarily constitute or imply its endorsement, recommendation, or favoring by the United States Government or any agency thereof, or Battelle Memorial Institute. The views and opinions of authors expressed herein do not necessarily state or reflect those of the United States Government or any agency thereof.

PACIFIC NORTHWEST NATIONAL LABORATORY
operated by
BATTELLE
for the
UNITED STATES DEPARTMENT OF ENERGY
under Contract DE-AC05-76RL01830

Printed in the United States of America

Available to DOE and DOE contractors from
the Office of Scientific and Technical Information,
P.O. Box 62, Oak Ridge, TN 37831-0062

www.osti.gov

ph: (865) 576-8401

fox: (865) 576-5728

email: reports@osti.gov

Available to the public from the National Technical Information Service
5301 Shawnee Rd., Alexandria, VA 22312

ph: (800) 553-NTIS (6847)

or (703) 605-6000

email: info@ntis.gov

Online ordering: <http://www.ntis.gov>



Office of Energy Efficiency
& Renewable Energy



For more information, visit:
www.energy.gov/eere/ssl

PNNL-35622 • November 2024

